

THIS DRAWING IS UNPUBLISHED. RELEASED FOR PUBLICATION
 © COPYRIGHT - By - ALL RIGHTS RESERVED.

LOC		DIST		REVISIONS			
P	LTR	DESCRIPTION	DATE	DWN	APVD		
	B	CHANGE LOGO;ADD CQC,LINE IDENTIFIER ECO-12-005725 FOR LINE IDENTIFIER; PLATING THICKNESS	20-AUG12	D.L	BH.Y		
	C	CHANGE THE VENT HOLE SHAPE FROM RECTANGLE TO CIRCLE ONE ECO-13-015347	16-DEC-13	XL,Y	B,F		

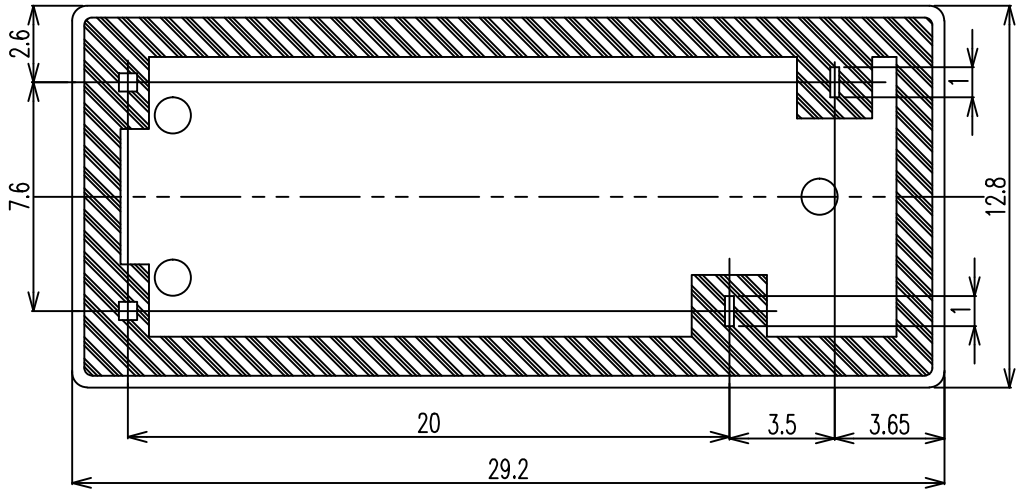
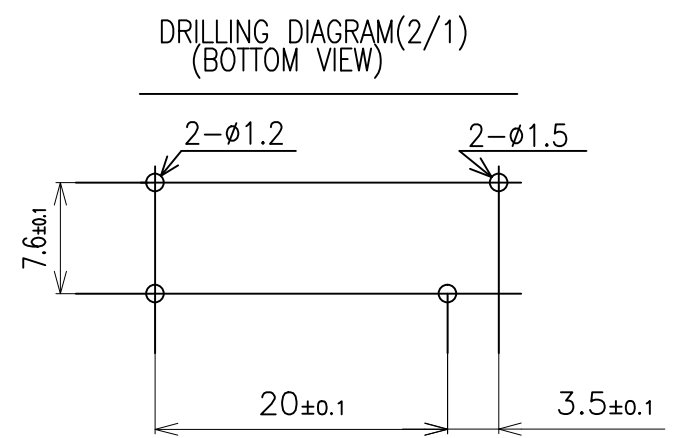
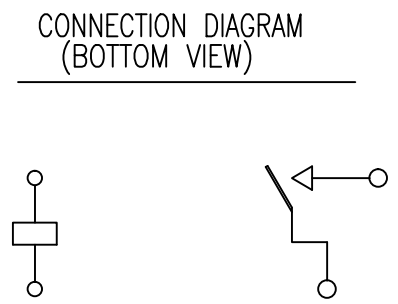
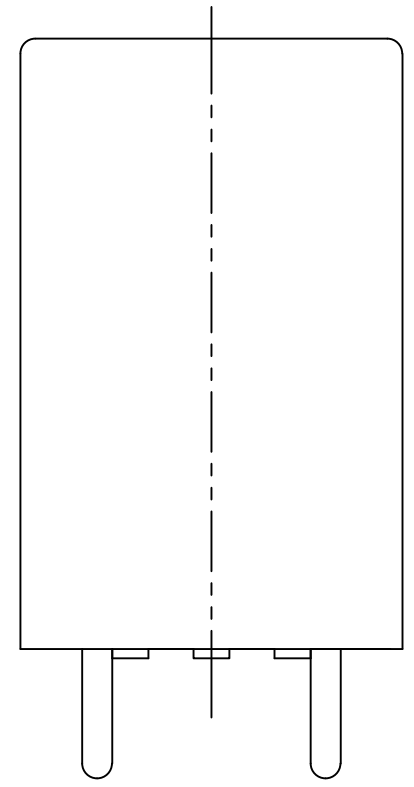
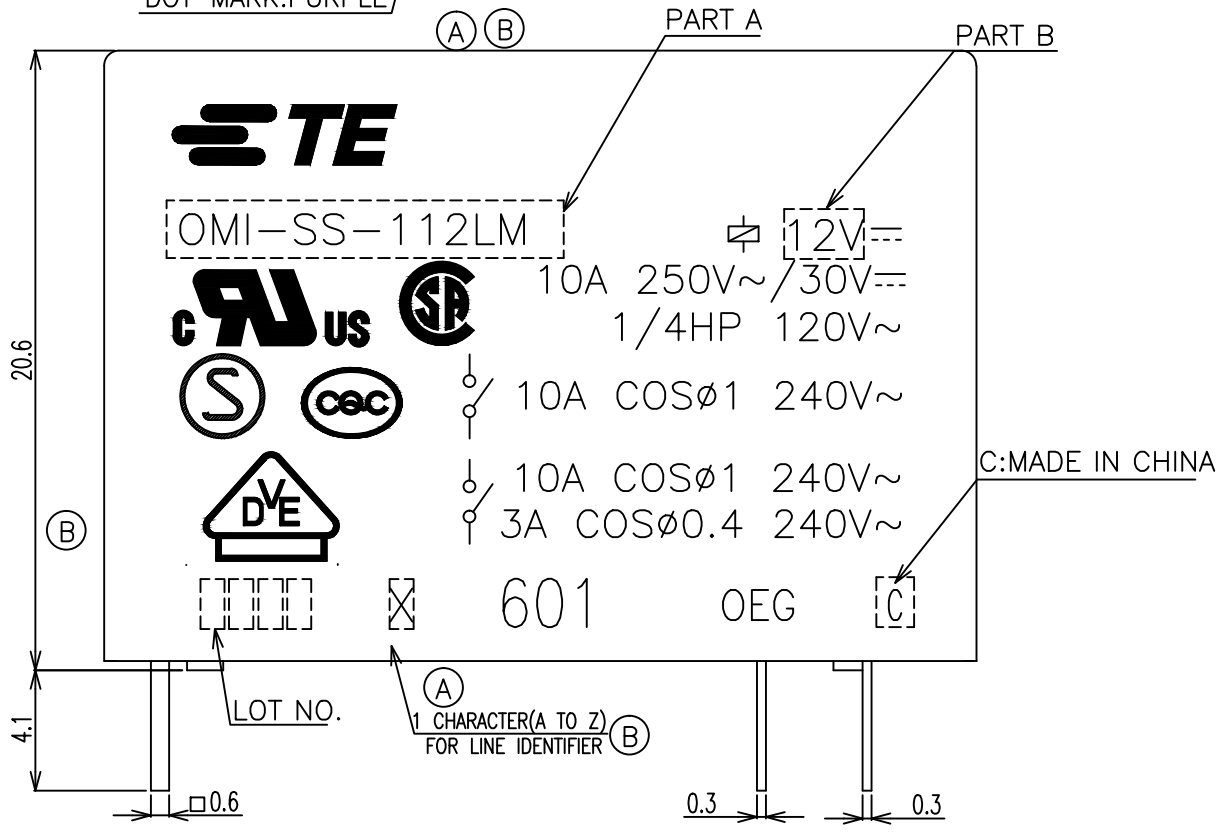
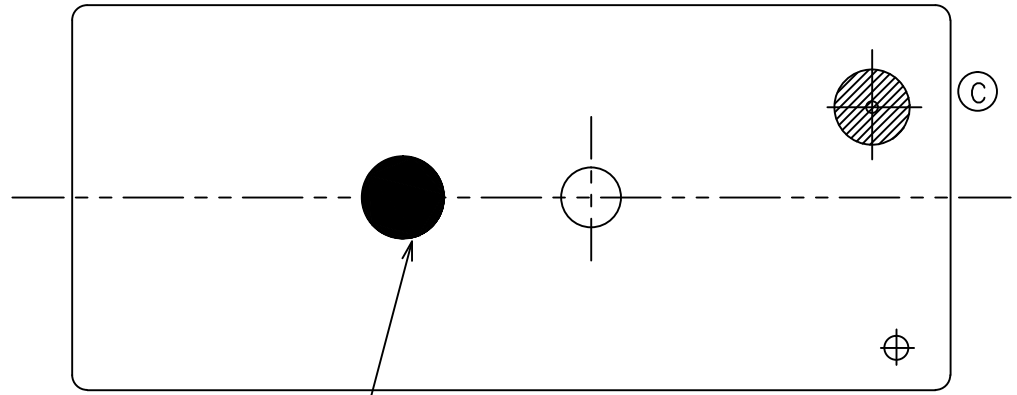

THIS DRAWING IS A CONTROLLED DOCUMENT.		DWN	H.SASAKI		TE Connectivity			
DIMENSIONS: mm		CHK	Y.OIKAWA					
TOLERANCES UNLESS OTHERWISE SPECIFIED:		APVD	A.NAGAI		NAME			
0 PLC ± - 1 PLC ± - 2 PLC ± - 3 PLC ± - 4 PLC ± - ANGLES ± -		PRODUCT SPEC	-		OMI-SH-LM SPEC,601 CUSTOMER DRAWING			
MATERIAL		FINISH	-		SIZE	CAGE CODE	DRAWING NO	RESTRICTED TO
-		-	-		A3	00779	C=2-1461183-5	-
CUSTOMER DRAWING					SCALE	SHEET	REV	
					4:1	1 OF 2	C	

THIS DRAWING IS UNPUBLISHED. RELEASED FOR PUBLICATION
 © COPYRIGHT - By - ALL RIGHTS RESERVED.

LOC	DIST	REVISIONS					
		P	LTR	DESCRIPTION	DATE	DWN	APVD
HB		-	-	SEE SHEET 1	-	-	-

- NOTES:
 1. TERMINAL DIMENSION IS NOT INCLUDING SOLDER TIP.
 (A) 2. LOT NO. SYSTEM AS FOLLOWING:

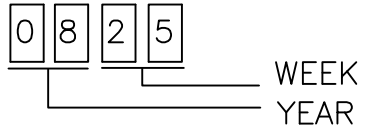

3. GENERAL TOLERANCE AS FOLLOWING:

TOLERANCE	
0~0.99mm	±0.1
1mm~2.99mm	±0.2
3mm MIN.	±0.3

- (B) 4. FOR THE TIN-PLATING OF THE PINS:
 +0.1mm FOR WIDTH, THICKNESS AND DIAMETER.
 +0.5mm FOR LENGTH.

3-1461183-2	OMI-SH-148LM	48V	OMI-SH-148LM
3-1461183-1	OMI-SH-136LM	36V	OMI-SH-136LM
3-1461183-0	OMI-SH-124LM	24V	OMI-SH-124LM
2-1461183-9	OMI-SH-118LM	18V	OMI-SH-118LM
2-1461183-8	OMI-SH-112LM	12V	OMI-SH-112LM
2-1461183-7	OMI-SH-109LM	9V	OMI-SH-109LM
2-1461183-6	OMI-SH-106LM	6V	OMI-SH-106LM
2-1461183-5	OMI-SH-105LM	5V	OMI-SH-105LM
TE PART NO	DESCRIPTION	PART B	PART A

RELAY TYPE

		UV RESIN	UV SEAL	16
		EPOXY RESIN	SEAL	15
UL94 V-0		PBT	CASE	14
CLASS E		UEW	MAGNETIC WIRE	13
UL94 V-0		PET	BASE	12
UL94 V-0		PBT	BOBBIN	11
	SOLDER DIP	CP WIRE	COIL TERMINAL	10
UL94 V-0		PPS	CARD	9
		Ag ALLOY	MOVABLE CONTACT	8
		Ag ALLOY	STATIONARY CONTACT	7
		Cu ALLOY	HINGE SPRING	6
	SOLDER DIP	Cu ALLOY	STATIONARY TERMINAL	5
	SOLDER DIP	Cu ALLOY	MOVABLE SPRING	4
		STEEL	CORE	3
		STEEL	ARMATURE	2
		STEEL	YOKE	1
INCOMBUSTIBILITY	TREATMENT	MATERIAL	DESCRIPTION	ITEM

THIS DRAWING IS A CONTROLLED DOCUMENT.		DWN		TE Connectivity	
DIMENSIONS: mm		CHK			
TOLERANCES UNLESS OTHERWISE SPECIFIED:		APVD		NAME	
0 PLC ± - 1 PLC ± - 2 PLC ± - 3 PLC ± - 4 PLC ± - ANGLES ± -		PRODUCT SPEC		OMI-SH-LM SPEC,601 CUSTOMER DRAWING	
MATERIAL		APPLICATION SPEC		SIZE	
FINISH		WEIGHT		CAGE CODE	
		CUSTOMER DRAWING		DRAWING NO	
				RESTRICTED TO	
				A3 00779 C-2-1461183-5	
				SCALE 4:1 SHEET 2 OF 2 REV C	