

All dimensions are in mm; tolerances: $\pm 3\text{mm}$ for $a \leq 300\text{mm}$; $\pm 1\%$ for $> 300\text{mm}$

Cables

Cable group H1

Micro coax cable $d=1.37\text{mm}$, center conductor AWG30
 Connector are only sold with cable.
 Picture on data sheet show an assembly example
 Minimum bending radius single $4x \varnothing$
 Minimum bending radius repeatable $8x \varnothing$

Available Variants

Type	Cable	Weight [$\pm 0,1\text{g}$]
LH1-071-XXX-NM	H1 (RTK013)	$4,6 \cdot 10^{-3} (\text{g/mm}) * a(\text{mm})$

XXX: length in mm = "a"

Technical Data 15S202-1H1

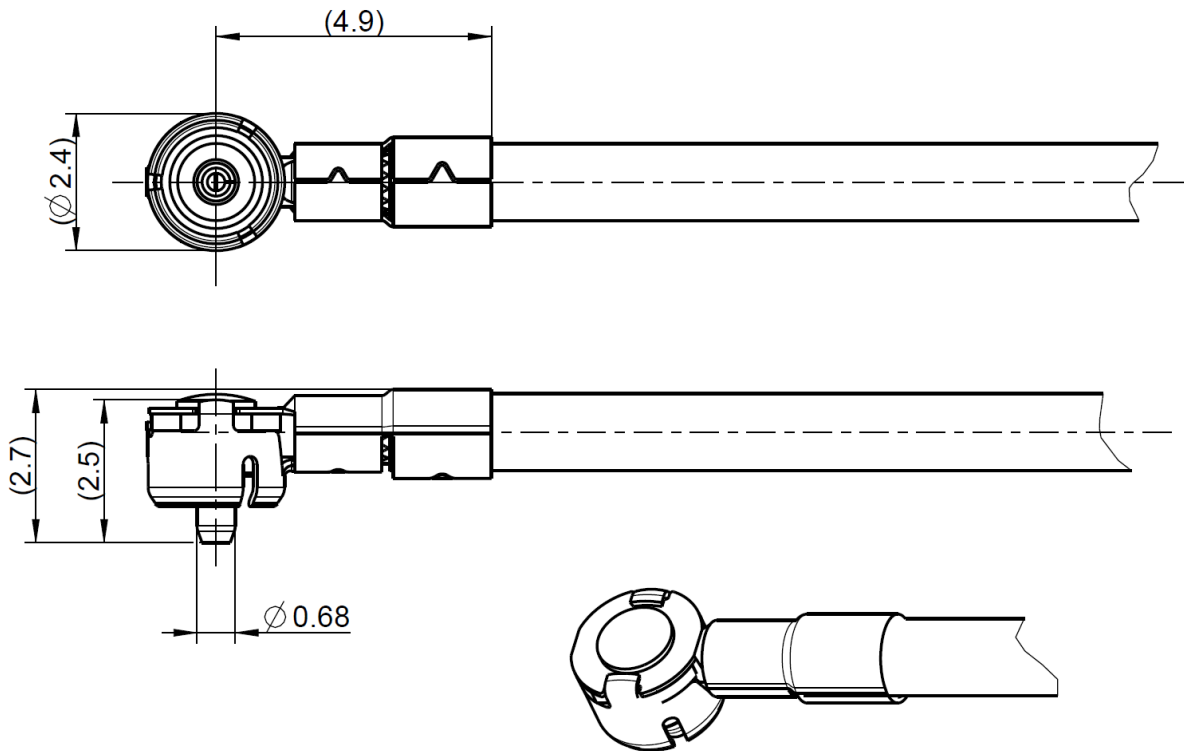

All dimensions are in mm; tolerances according to ISO 2768 m-H

Interface

According to 15K101-40M RF Test Switch

Material and plating

Connector parts

- Center contact
- Outer contact
- Cover
- Insulator

Material

- Spring bronze
- Spring bronze
- Spring bronze
- TPX

Plating

- 3-6µm Ag over 0.2-1.0µm Cu
- 3-6µm Ag over 0.2-1.0µm Cu
- 3-6µm Ag over 0.2-1.0µm Cu

Electrical data

Impedance	50 Ω
Frequency	DC to 6 GHz
Return loss	≥ -26 dB, DC to 2 GHz ≥ -23 dB, 2 to 4 GHz ≥ -18 dB, 4 to 6 GHz
Insulation resistance	$\geq 0.5 \times 10^3$ M Ω
Center contact resistance	≤ 50 m Ω
Outer contact resistance	≤ 100 m Ω
Shielding effectiveness	> 40 dB up to 3 GHz > 35 dB up to 6 GHz

Mechanical data

Mating cycles	≥ 25
Mating force	≤ 45 N
Unmating force	≥ 2 N
Mated height	2.4 mm

Environmental data

Temperature range	-40°C to +90°C
Storage temperature	-40°C to +90°C
RoHS	compliant

Cable load

After mating do not apply higher forces than defined in the picture below.

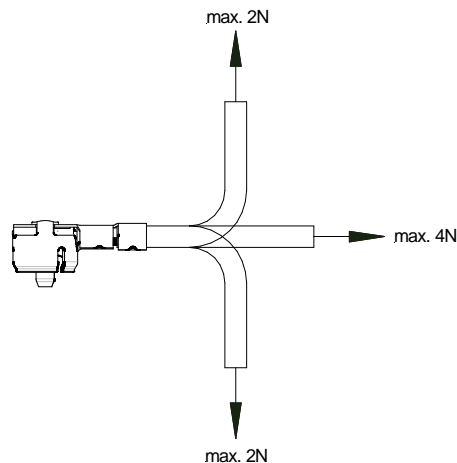

Mating and un-mating

For the reliable un-mating of the cable connector a special tool is dedicated :

Un-mating tool 15W004-000

Usage remarks:

1. The vertical mating axis of the PCB receptacle and the cable connector has to be aligned during the connecting and a click will confirm that the connectors are mated correctly.
2. The disconnection of the 2 connectors is carried out vertically with the tool 15W004-000 in the mating axis of the 2 connectors.
3. The connectors should not be mated under an extreme angle.
4. Avoid the forcefull twisting or deforming of the cable.

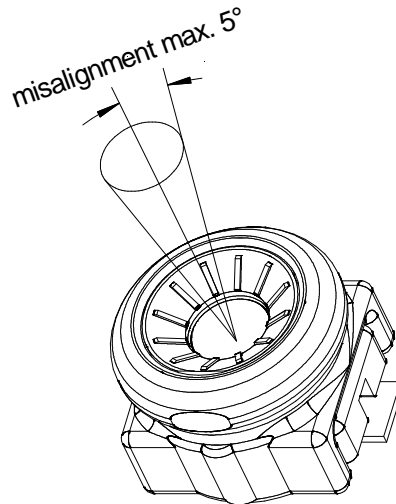

Packing

Standard

25 pcs in plastic bag

While the information has been carefully compiled to the best of our knowledge, nothing is intended as representation or warranty on our part and no statement herein shall be construed as recommendation to infringe existing patents. In the effort to improve our products, we reserve the right to make changes judged to be necessary.

Draft	Date	Approved	Date	Rev.	Engineering change number	Name	Date
C. Kainzmaier	05.08.15	C. Kainzmaier	13.05.16	b00	16-0003	A. Streibl	13.05.16

Rosenberger Hochfrequenztechnik GmbH & Co. KG
 P.O.Box 1260 D-84526 Tittmoning Germany
www.rosenberger.de

Tel.: +49 8684 18-0
 Fax: +49 8684 18-499
 email: info@rosenberger.de

Page
 4 / 4