



TAI-SAW TECHNOLOGY CO., LTD.

No. 3, Industrial 2nd Rd., Ping-Chen Industrial District,
Taoyuan, 324, Taiwan, R.O.C.

TEL: 886-3-4690038 FAX: 886-3-4697532

E-mail: tstsales@mail.taisaw.com Web: www.taisaw.com

Product Specification Approval Sheet

Product Name: SAW Filter 2250 MHz SMD 3.0X3.0 mm

TST Parts No.: TA0700B

Customer Parts No.: _____

Customer signature required

Company: _____

Division: _____

Approved by : _____

Date: _____

Checked by: _____ Anne Chen 

Approved by: _____ Francis Chen 

Date: _____ 9, 08, 2010

1. Customer signed back is required before TST can proceed with sample build and receive orders.
2. Orders received without customer signed back will be regarded as agreement on the specifications.
3. Any specifications changes must be approved upon by both parties and a new revision of specifications shall be released to reflect the changes.



TAI-SAW TECHNOLOGY CO., LTD.

No. 3, Industrial 2nd Rd., Ping-Chen Industrial District,
Taoyuan, 324, Taiwan, R.O.C.

TEL: 886-3-4690038 FAX: 886-3-4697532

E-mail: tstsales@mail.taisaw.com Web: www.taisaw.com

SAW Filter 2250 MHz

MODEL NO.:TA0700B

REV. NO.:1

A. MAXIMUM RATING:

1. Input Power Level: 10 dBm
2. DC Voltage : 3V
3. Operating Temperature: -40°C to +85°C
4. Storage Temperature: -40°C to +85°C

RoHS Compliant
Lead free
Lead-free soldering

B. ELECTRICAL CHARACTERISTICS:

Item	Unit	Min.	Type.	Max.	Note
Center Frequency Fc	MHz	-	2250	-	-
Insertion Loss (2200 ~ 2300 MHz) IL	dB	-	3.2	4.5	-
Amplitude Ripple (2200 ~ 2300 MHz)	dB	-	1.9	3	-
VSWR (2200 ~ 2300 MHz)		-	1.9	2.5	-
Attenuation (Reference level from 0 dB)					
D.C. ~ 2160 MHz	dB	25	28	-	-
2340 ~ 4000 MHz	dB	25	32.5	-	-

C. MEASUREMENT CIRCUIT:

HP Network analyzer

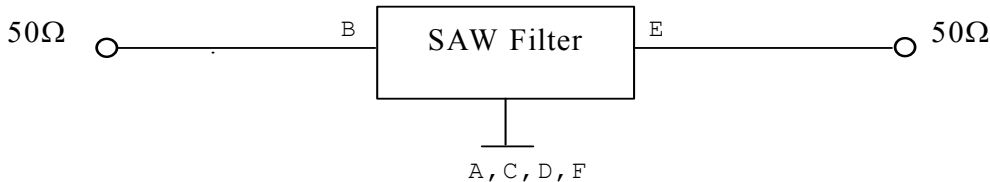

D.OUTLINE DRAWING:

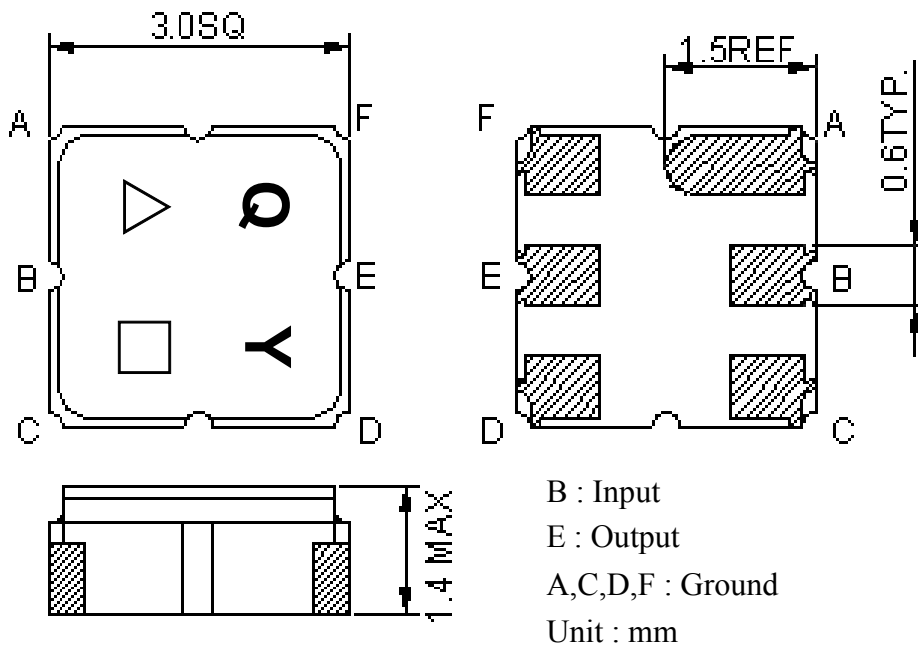

△ : Year Code (2010->0, ..., 2019->9)

□ : Date Code (Follow the table from planner each year)

E. PCB Footprint:

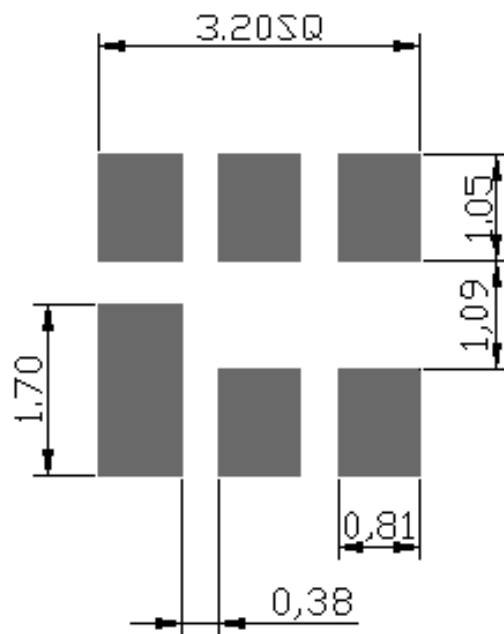

F. Frequency Characteristics :

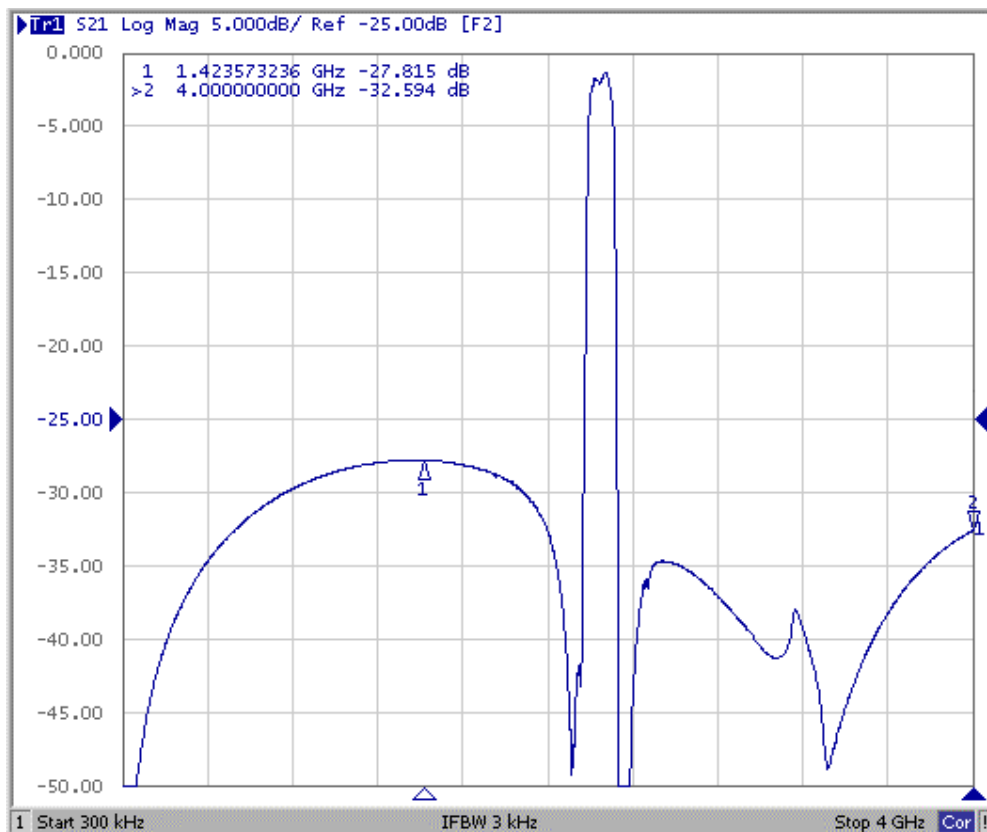
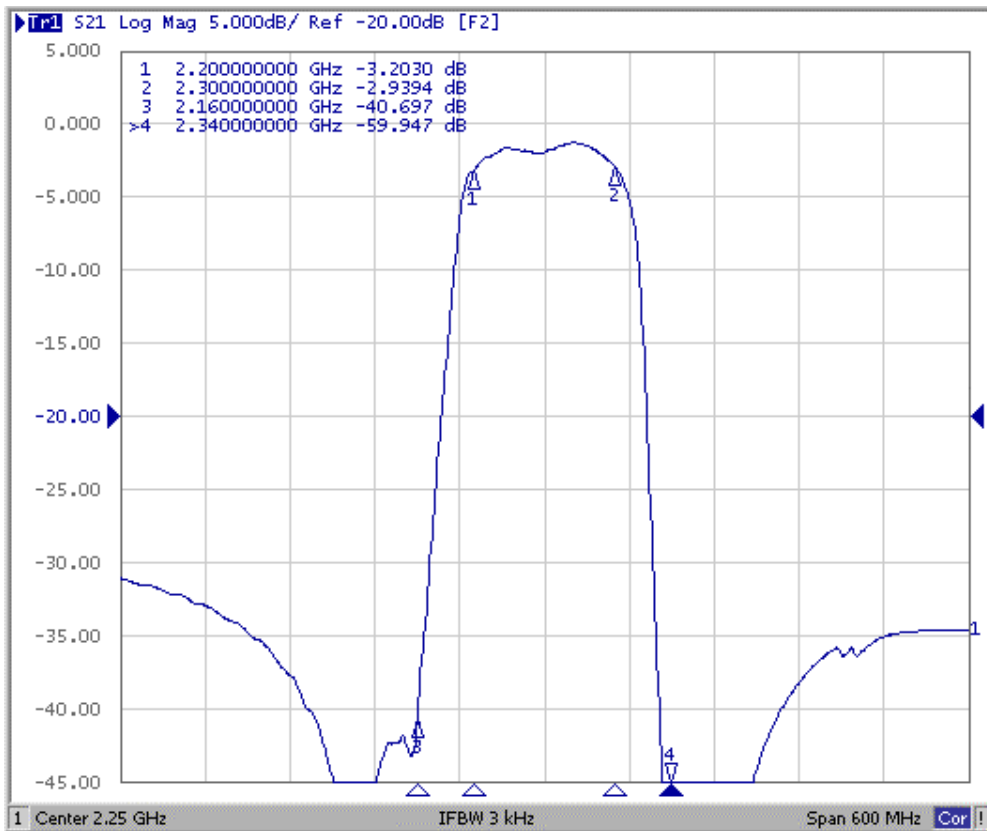

Reflection Functions :

S11

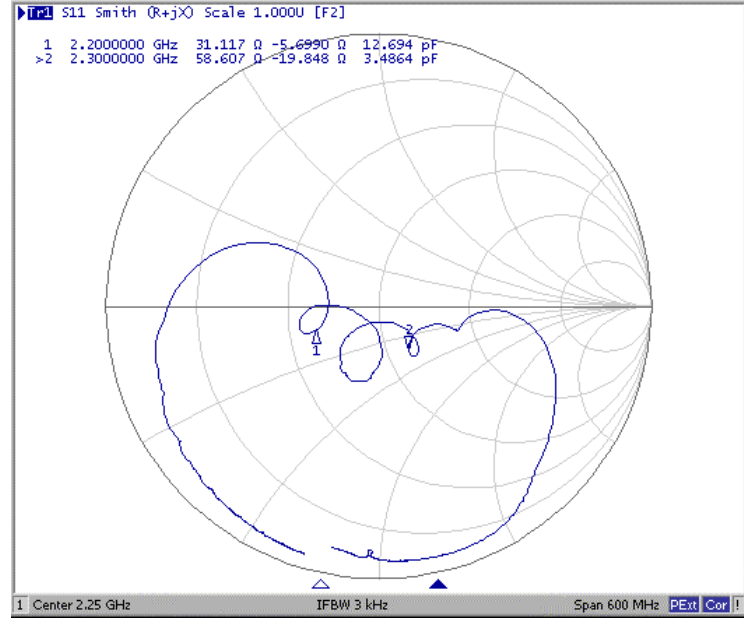
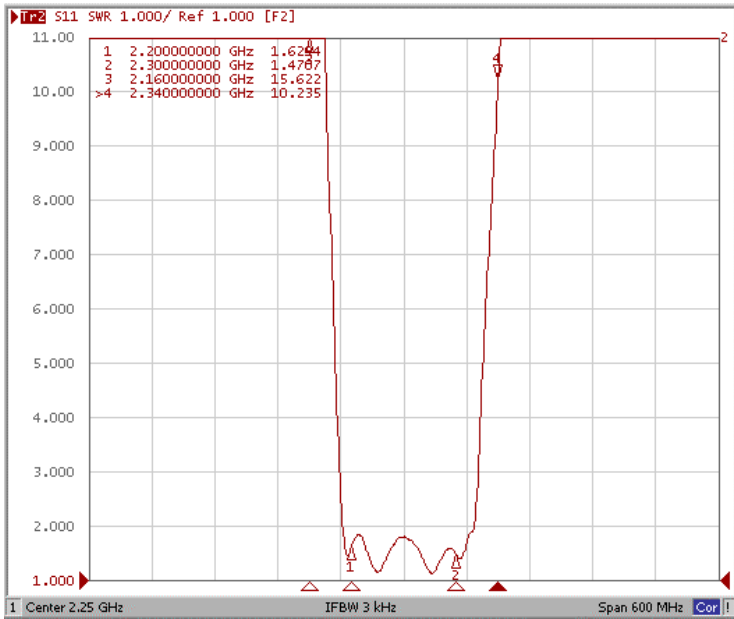

S22

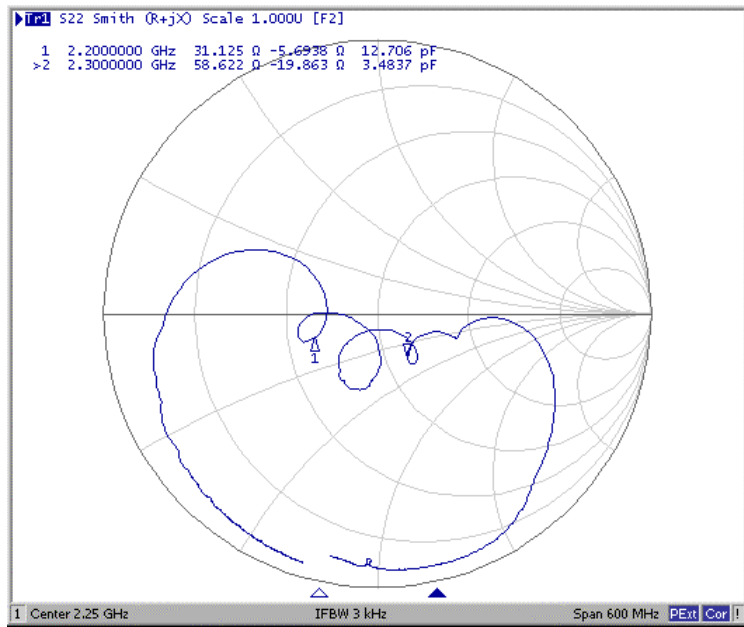
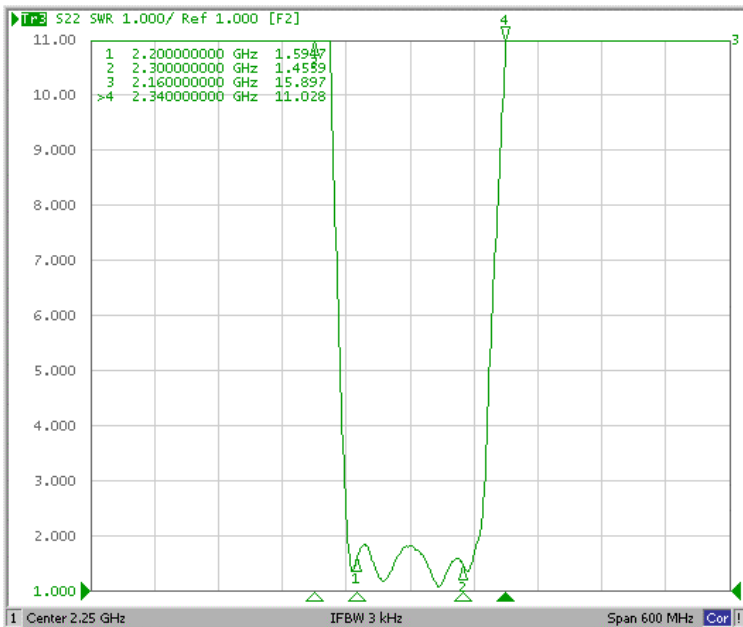

G. PACKING:

1. REEL DIMENSION

(Reel Count : 7''=1000 ; 13''=3000)



2.TAPE DIMENSION

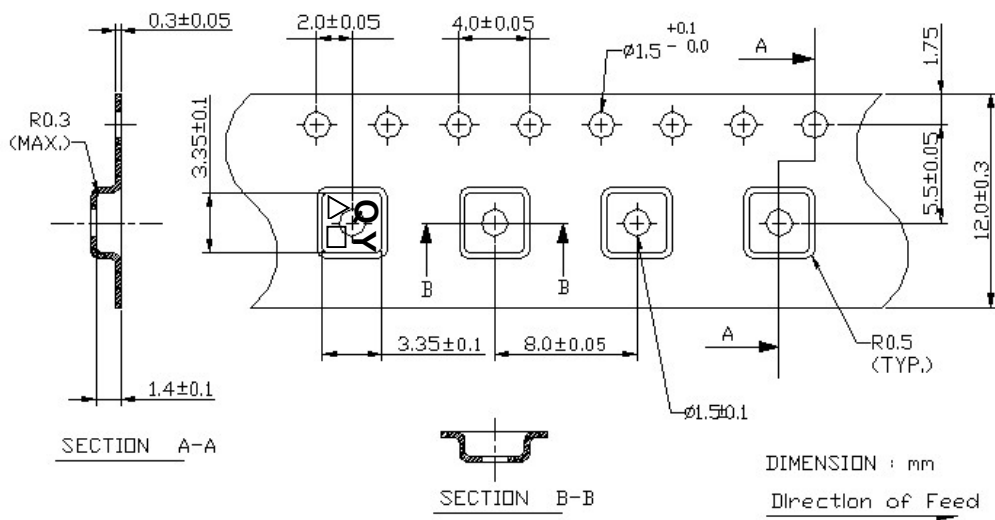

H. RECOMMENDED REFLOW PROFILE :

