



MLP1-SMMCOAC

MLP1

SAFETY LOCKING DEVICES

SICK
Sensor Intelligence.



Ordering information

Type	Part no.
MLP1-SMMC0AC	1077942

Other models and accessories → www.sick.com/MLP1



Detailed technical data

Features

Sensor principle	Transponder
Locking force	500 N
Retaining force	25 N
Offset tolerance	≤ 5 mm
Safe switch off distance S_{ar}	45 mm
For process protection only	✓

Safety-related parameters

Safety integrity level	SIL3 (IEC 61508), SILCL3 (EN 62061)
Category	Category 4 (EN ISO 13849)
Performance level	PL e (EN ISO 13849) ¹⁾
PFD_D (mean probability of a dangerous failure per hour)	1.5×10^{-8} (EN ISO 13849) ²⁾
T_M (mission time)	20 years (EN ISO 13849)
Type	Type 4 (EN ISO 14119)
Actuator coding level	Low coding level (EN ISO 14119)
Safe state in the event of a fault	At least one safety-related semiconductor output (OSSD) is in the OFF state.

¹⁾ In a cascade, the performance level for the cascade as a whole depends on the number and type of devices in the cascade. PL e is only possible in cascades with a maximum of 6 devices.

²⁾ At 40 °C and 1000 m above sea level.

Functions

Cascading	✓ (directly cascadable)
------------------	-------------------------

Interfaces

Connection type	Cable with plug M12, 5-pin, Cable with female connector, M12, 5-pin
Length of cable	150 mm
Cable material	PVC

Connecting cable length	≤ 140 m
-------------------------	---------

Electrical data

Protection class	III (IEC 61140)
Contamination rating	3 (EN 60947-1)
Classification according to cULus	Class 2
Usage category	DC-13 (IEC 60947-5-1)
Rated insulation voltage U_i	32 V
Rated impulse withstand voltage U_{imp}	1,500 V
Supply voltage U_V when an individual safety switch is connected	
Sensor	24 V DC (19.2 V DC ... 28.8 V DC)
Magnet	24 V DC (19.2 V DC ... 28.8 V DC)
Supply voltage U_V when a cascade is connected	
Sensor	24 V DC (22.8 V DC ... 28.8 V DC)
Magnet	24 V DC (21.6 V DC ... 28.8 V DC)
Power consumption	
Locking active	350 mA
Locking deactivated	50 mA
Switching frequency	≤ 0.5 Hz
Type of output	Semiconductor (OSSD)
Output current (OSSDs)	≤ 100 mA
Diagnostic output	≤ 25 mA, short-circuit protected
Cable capacitance	400 nF (for OUT A and OUT B)
Response time	50 ms ¹⁾
Enable time	100 ms ¹⁾
Risk time	100 ms ¹⁾
Switch-on time	2.5 s
Locking principle	Power to lock

¹⁾ In a cascade, the value is multiplied by the number of safety switches in the cascade.

Mechanical data

Weight		
Switches		510 g
Actuator		210 g
Material		
Sensor housing		Anodized aluminum
Actuator housing		Fiber-glass-reinforced PVC
Anchor plate		Nickel-plated steel
Dimensions (W x H x D)		
Switches		120 mm x 60 mm x 38.5 mm
Actuator		120 mm x 60 mm x 20.5 mm

Offset tolerance	Vertical	≤ 5 mm
	Horizontal	≤ 5 mm
	Aperture angle	≤ 3°

Ambient data

Enclosure rating	IP67 (EN 60529)
Ambient operating temperature	-20 °C ... +55 °C
Storage temperature	-25 °C ... +70 °C
Relative humidity	50 %, at 70 °C (IEC 60947-5-2)
Vibration resistance	10 Hz ... 55 Hz, 1 mm (IEC 60068-2-6)
Shock resistance	30 g, 11 ms (EN 60068-2-27)
EMC	EN IEC 61326-3-1 EN IEC 60947-5-2 EN IEC 60947-5-3

Classifications

ECl@ss 5.0	27272603
ECl@ss 5.1.4	27272603
ECl@ss 6.0	27272603
ECl@ss 6.2	27272603
ECl@ss 7.0	27272603
ECl@ss 8.0	27272603
ECl@ss 8.1	27272603
ECl@ss 9.0	27272603
ETIM 5.0	EC002593
ETIM 6.0	EC002593
UNSPSC 16.0901	39122205

Dimensional drawing (Dimensions in mm (inch))

Sensor with M12 male connector and M12 socket

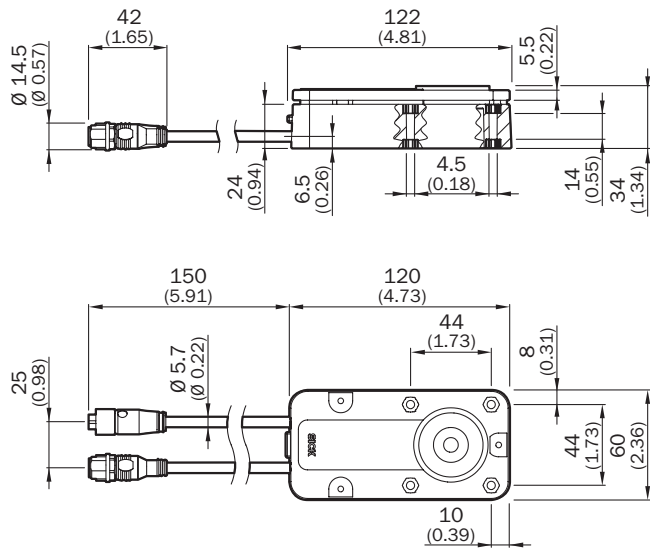

Actuator

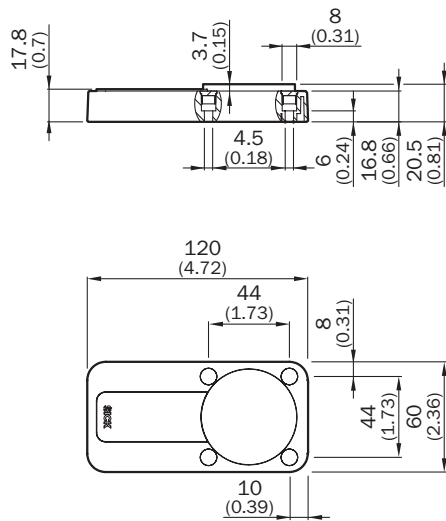

Recess for flush mounting

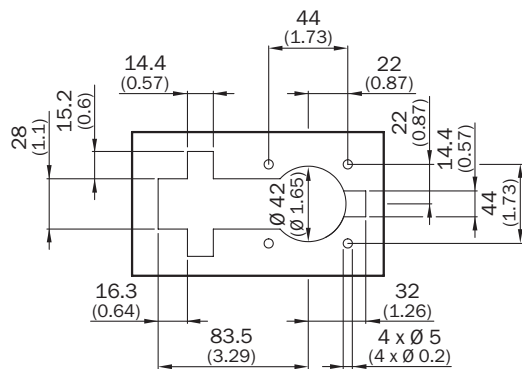

Series connection

Connecting an additional voltage supply

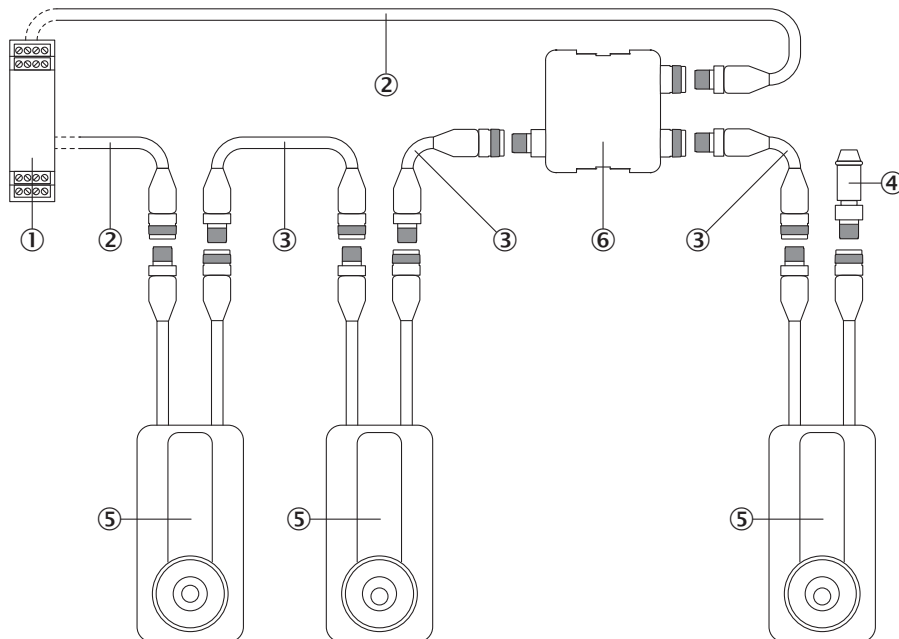

- ① Safe evaluation unit
- ② Connecting cable with 5-pin, M12 female connector and flying leads (e.g., YF2A15-xxxVB5XLEAX)
- ③ Connection cable with 5-pin, M12 male connector and 5-pin, M12 female connector (e.g., YF2A15-xxxUB5M2A15)
- ④ End plug
- ⑤ MLP1 safety switch (2 × M12, 5-pin)
- ⑥ Nodes for voltage supply

Connecting directly connected safety switches

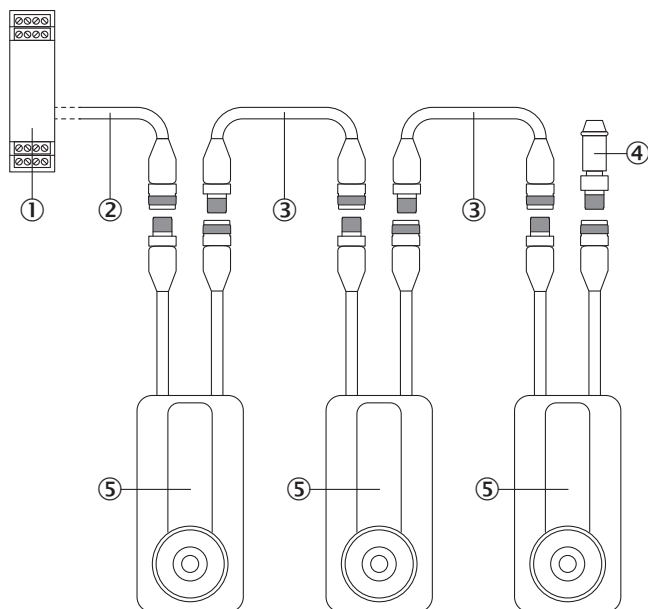

- ① Safe evaluation unit
- ② Connecting cable with 5-pin, M12 female connector and flying leads (e.g., YF2A15-xxxVB5XLEAX)
- ③ Connection cable with 5-pin, M12 male connector and 5-pin, M12 female connector (e.g., YF2A15-xxxUB5M2A15)
- ④ End plug
- ⑤ MLP1 safety switch (2 × M12, 5-pin)

Combining connection methods as desired

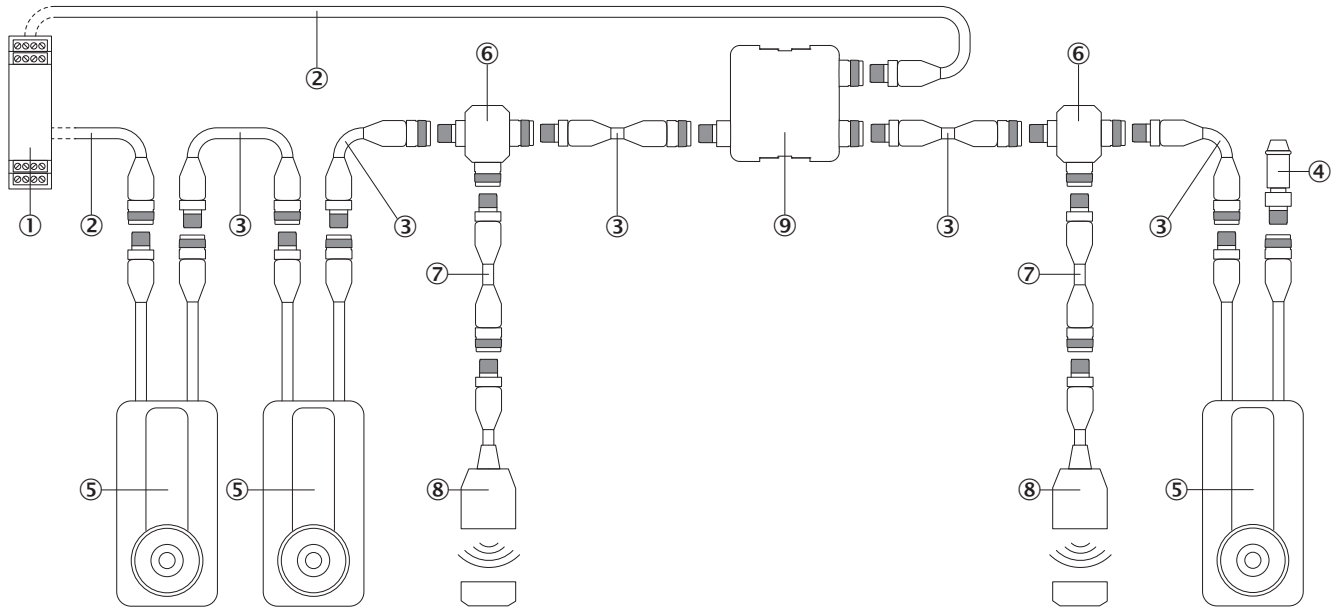

- ① Safe evaluation unit
- ② Connecting cable with 5-pin, M12 female connector and flying leads (e.g., YF2A15-xxxVB5XLEAX)
- ③ Connection cable with 5-pin, M12 male connector and 5-pin, M12 female connector (e.g., YF2A15-xxxUB5M2A15)
- ④ End plug
- ⑤ MLP1 safety switch
- ⑥ T-piece
- ⑦ Connection cable with 8-pin, M12 male connector and 8-pin, M12 female connector (e.g., YF2A18-xxxUA5M2A18)
- ⑧ Safety switch, M12, 8-pin
- ⑨ Nodes for voltage supply

Connection diagram

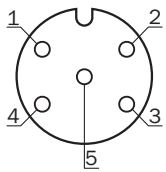
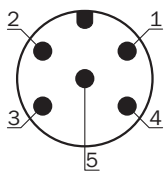

Pin	Designation	Description
1	In 24 V DC	Safety switch voltage supply
2	OSSD 1	OSSD 1 output
3	0 V	0 V DC voltage supply

Pin	Designation	Description
4	OSSD 2	OSSD 2 output
5	Magnet	Magnet control 24 V DC input

SICK AT A GLANCE

SICK is one of the leading manufacturers of intelligent sensors and sensor solutions for industrial applications. A unique range of products and services creates the perfect basis for controlling processes securely and efficiently, protecting individuals from accidents and preventing damage to the environment.

We have extensive experience in a wide range of industries and understand their processes and requirements. With intelligent sensors, we can deliver exactly what our customers need. In application centers in Europe, Asia and North America, system solutions are tested and optimized in accordance with customer specifications. All this makes us a reliable supplier and development partner.

Comprehensive services complete our offering: SICK LifeTime Services provide support throughout the machine life cycle and ensure safety and productivity.

For us, that is “Sensor Intelligence.”

WORLDWIDE PRESENCE:

Contacts and other locations –www.sick.com