



PLCC Lamps

LTL-94PCK-TA	AlGaAs Red
LTL-94PURK-TA	AlGaAs Red
LTL-94PEK-TA	Red Orange
LTL-94PYK-TA	Yellow
LTL-94PGK-TA	Green
LTL-94PAK-TA	Amber
LTL-94PKK-TA	Pure Green

Features

- Package in 8mm tape on 7" diameter reels.
- Compatible with automatic placement equipment.
- Compatible with infrared and vapor phase reflow solder process.
- EIA STD package.
- I.C. compatible.

Description

The AlGaAs Red source color devices are made with Aluminum Gallium Arsenide Red Light Emitting Diode.

The Orange and Amber source color devices are made with Arsenide Gallium Phosphide on Gallium Phosphide Orange Light Emitting Diode.

The Green source color devices are made with Gallium Phosphide on Gallium Phosphide Green Light Emitting Diode.

The Yellow source color devices are made with Gallium Arsenide Phosphide on Gallium Phosphide Yellow Light Emitting Diode.

Package Dimensions

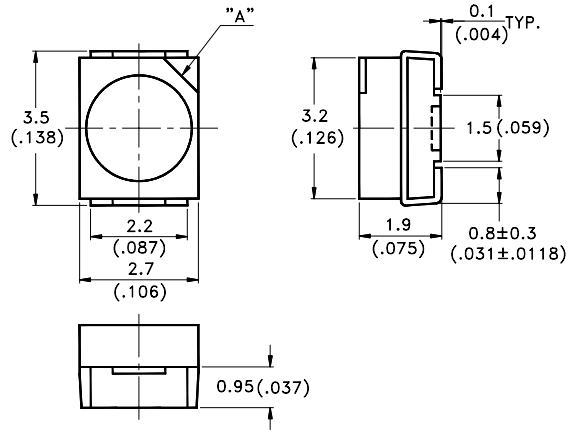

Notes:

1. All dimensions are in millimeters (inches).
2. Tolerance is $\pm 0.2\text{mm} (.008\text{")}$ unless otherwise noted.
3. LTL-94PEK-TA, 94PGK-TA, 94PYK-TA, 94PAK-TA, 94PKK-TA, "A" identify cathode.
LTL-94PURK-TA, 94PCK-TA, "A" identify anode.

Devices

Part No. LTL-	Lens	Source Color
94PURK-TA 94PCK-TA	Water Clear	AlGaAs Red
94PEK-TA	Water Clear	Red Orange
94PGK-TA	Water Clear	Green
94PKK-TA	Water Clear	Pure Green
94PYK-TA	Water Clear	Yellow
94PAK-TA	Water Clear	Amber

Absolute Maximum Ratings at Ta=25°C

Parameter	AlGaAs Red	Red Orange	Green Pure Green	Yellow	Unit
Power Dissipation	100	100	100	60	mW
Peak Forward Current (1/10 Duty Cycle, 0.1ms Pulse Width)	200	120	120	80	mA
Continuous Forward Current	40	30	30	20	mA
Derating Linear From 50°C	0.8	0.6	0.6	0.4	mA/°C
Reverse Voltage	5	5	5	5	V
Operating Temperature Range	-55°C to +100°C				
Storage Temperature Range	-55°C to +100°C				
Infrared Soldering Condition	260°C for 5 Seconds				
Vapor phase Soldering Condition	215°C for 3 minutes				
Wave Soldering Condition	260°C for 5 Seconds				

Electrical / Optical Characteristics and Curves at Ta = 25°C

Parameter	Symbol	Part No. LTL-	Min.	Typ.	Max.	Unit.	Test Condition.
Luminous Intensity	I_v	94PURK-TA 94PCK-TA	29 20	80.0 50.0		mcd	$I_f=20$ mA Note 1
Viewing Angle	$2\theta^{1/2}$	94PURK-TA 94PCK-TA		120		deg	Note 2 (FIG.22)
Peak Emission Wavelength	λ_P	94PURK-TA 94PCK-TA		660		nm	Measurement @Peak (FIG.1)
Dominant Wavelength	λ_d	94PURK-TA 94PCK-TA		638		nm	Note 3
Spectral Line Half Width	$\Delta\lambda$	94PURK-TA 94PCK-TA		20		nm	
Forward Voltage	V_F	94PURK-TA 94PCK-TA		1.8	2.4	V	$I_f=20$ mA
Reverse Current	I_R	94PURK-TA 94PCK-TA			100	μ A	$V_R=5$ V
Capacitance	C	94PURK-TA 94PCK-TA		30		PF	$V_f=0$ f=1MHZ

Notes:1. Luminous intensity is measured with a light sensor and filter combination that approximates the CIE eye-response curve.

2. $2\theta^{1/2}$ is the off-axis angle at which the luminous intensity is half the axial luminous intensity.

3. The dominant wavelength, λ_d is derived from the CIE chromaticity diagram and represents the single wavelength which defines the color of the device.

Electrical / Optical Characteristics at Ta=25°C

Parameter	Symbol	Part No. LTL-	Min.	Typ.	Max.	Unit.	Test Condition.
Luminous Intensity	Iv	94PEK-TA 94PGK-TA 94PYK-TA 94PAK-TA 94PKK-TA	1.7 1.7 1.7 1.7 0.7	8.0 8.0 6.0 8.0 2.5		mcd	If=10 mA Note 1
Viewing Angle	2θ _{1/2}	All		120		deg	Note 2 (Fig.7)
Peak Emission Wavelength	λ P	94PEK-TA 94PGK-TA 94PYK-TA 94PAK-TA 94PKK-TA		635 565 585 610 555		nm	Measurement @Peak (Fig.1)
Dominant Wavelength	λ d	94PEK-TA 94PGK-TA 94PYK-TA 94PAK-TA 94PKK-TA		621 569 588 602 557		nm	Note 3
Spectral Line Half Width	Δλ	94PEK-TA 94PGK-TA 94PYK-TA 94PAK-TA 94PKK-TA		40 30 35 35 30		nm	
Forward Voltage	V _F	94PEK-TA 94PGK-TA 94PYK-TA 94PAK-TA 94PKK-TA		2.0 2.1 2.1 2.1 2.1	2.8	V	If=20mA
Reverse Current	I _R	94PEK-TA 94PGK-TA 94PYK-TA 94PAK-TA 94PKK-TA			100	μ A	V _R =5V
Capacitance	C	94PEK-TA 94PGK-TA 94PYK-TA 94PAK-TA 94PKK-TA		20 35 15 10 35		PF	V _F =0 f=1MHZ

Notes:1. Luminous intensity is measured with a light sensor and filter combination that approximates the CIE eye-response curve.

2. 2θ_{1/2} is the off-axis angle at which the luminous intensity is half the axial luminous intensity.

3. The dominant wavelength, λ d is derived from the CIE chromaticity diagram and represents the single wavelength which defines the color of the device.

Typical Electrical/Optical Characteristics Curves (25°C Ambient Temperature Unless Otherwise Noted)

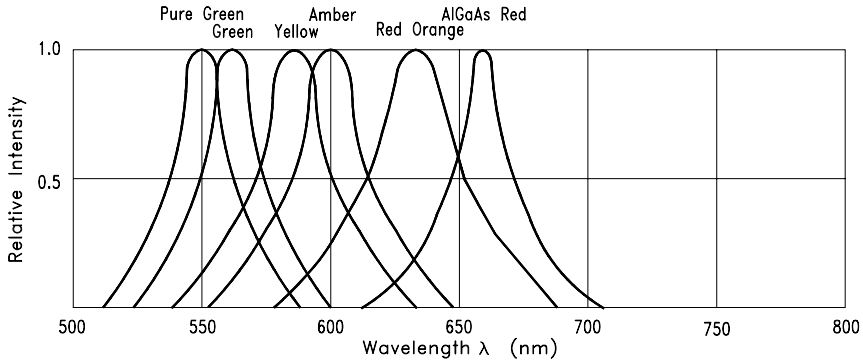

Fig.1 RELATIVE INTENSITY VS. WAVELENGTH

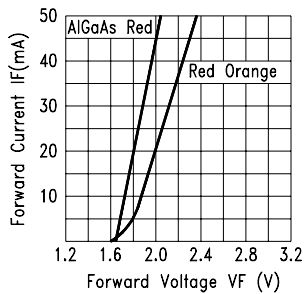

Fig.2 FORWARD CURRENT VS. FORWARD VOLTAGE

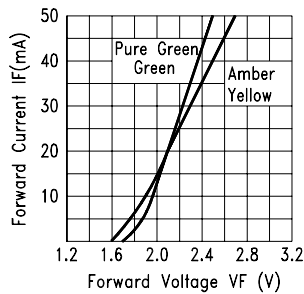

Fig.3 FORWARD CURRENT VS. FORWARD VOLTAGE

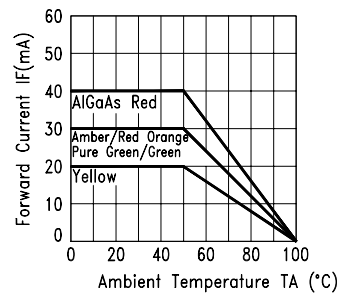

Fig.4 FORWARD CURRENT DERATING CURVE

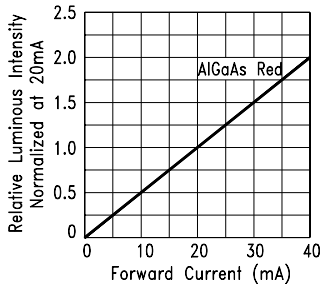

Fig.5 RELATIVE LUMINOUS INTENSITY VS. FORWARD CURRENT

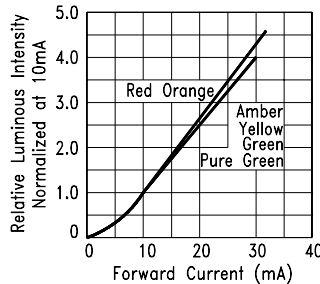

Fig.6 RELATIVE LUMINOUS INTENSITY VS. FORWARD CURRENT

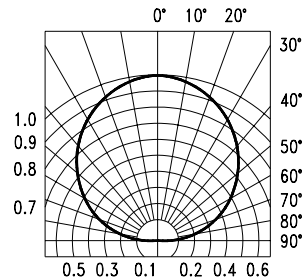

Fig.7 SPATIAL DISTRIBUTION

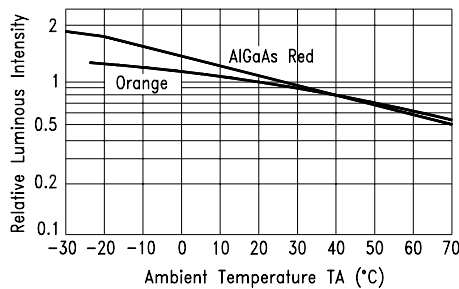

Fig.8 LUMINOUS INTENSITY VS. AMBIENT TEMPERATURE

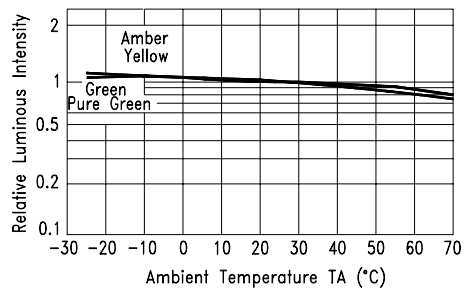

Fig.9 LUMINOUS INTENSITY VS. AMBIENT TEMPERATURE

User Guide

Cleaning

Do not use unspecified chemical liquid to clean LED they could harm the package.

If cleaning is necessary, immerse the LED in ethyl alcohol or isopropyl alcohol at

normal temperature for less one minute.

Soldering Pad Dimensions

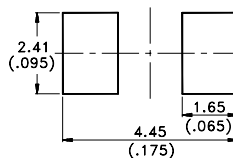

Package Dimensions of Tape

LTL-94PEK-TA / 94PGK-TA / 94PYK-TA/94PAK-TA/94PKK-TA

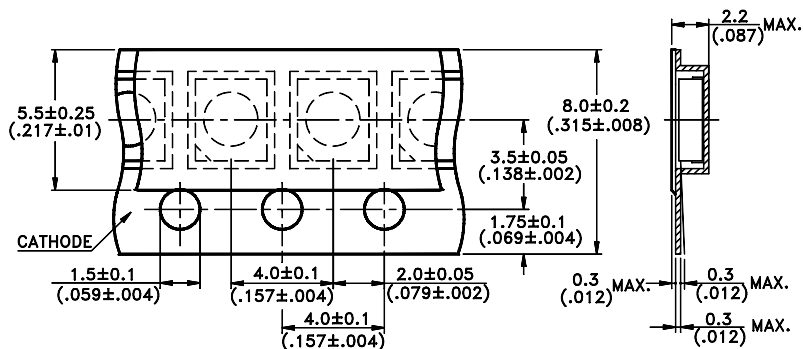

LTL-94PURK-TA / 94PCK-TA

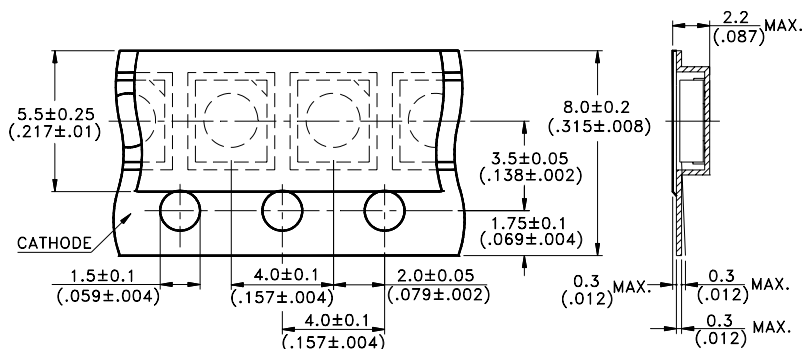

Package Dimensions of Tape and Reel

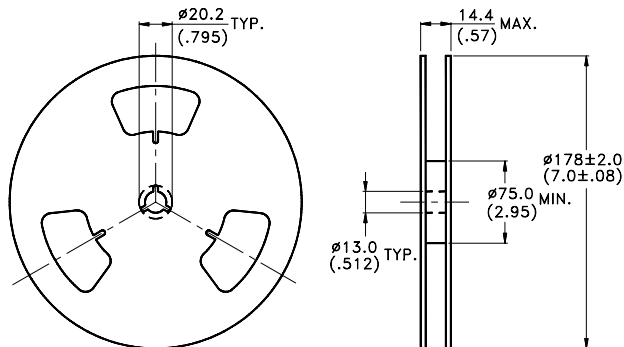

Notes: 1. Empty component pockets sealed with top cover tape.

2. 7 inch reel - 1500 pieces per reel.

3. The maximum number of consecutive missing lamp are two.

4. In accordance with ANSI/EIA RS-481 specifications the cathode is oriented towards the tape sprocket hole.

5. All dimensions are in millimeters (inches).