

NiM1B

Issue 2, 09 February 2018

Frequency Programmable 25kHz NBFM VHF Transceiver

The narrow band NiM1B transceiver offers a low power, reliable data link in a Radiometrix transceiver standard pin out and footprint. The NiM1B is a frequency programmable, narrowband design, suitable for licensed and unlicensed VHF allocations, FCC part 90 and part 95 (MURS) operations.



Figure 1: NiM1B (MURS)

Features

- Conforms to EN 300 220-3 and EN 301 489-3 (10mW version only)
- Compliant with FCC part 90 and part 95 (MURS)
- Standard frequency 154.570MHz or 154.600MHz (re-programmable)
- Other frequencies from 120MHz to 175MHz
- Data rates up to 5kbps for standard module
- Usable range over 1km
- Fully screened
- Low power requirements
- 25kHz Channel spacing
- Feature-rich interface (true analogue and/or digital baseband)

The NiM1B is a half duplex radio transceiver module for use in long range bi-directional data transfer applications at ranges up to 1kilometres. The module operates on the US 154MHz MURS band allocation. NiM1B is also available as separate NiM1BT transmitter and NiM1BR receiver, which can be, used as dual-in-line equivalents of TX1 transmitter and RX1/NRX1 receiver respectively.

Applications

- Multi-Use Radio Service (MURS)
- Industrial telemetry and telecommand
- High-end security systems
- Vehicle data up/download
- ROV/machinery controls

Technical Summary

- Fully integrated sigma-delta PLL synthesizer based design
- High stability TCXO reference
- Data bit rate: 5kbps max.
- Transmit power: +13dBm (20mW)
- Image rejection: >70dB
- Receiver sensitivity: -120dBm (for 12dB SINAD)
- RSSI output with >50dBm range
- Supply: 3.3V - 15V @ 30mA transmit, 18mA receive
- Dimensions: 33 x 23 x 11mm (fully screened)

Evaluation platforms: NBEK + BiM / SMX carrier

NiM1B Single channel transceiver

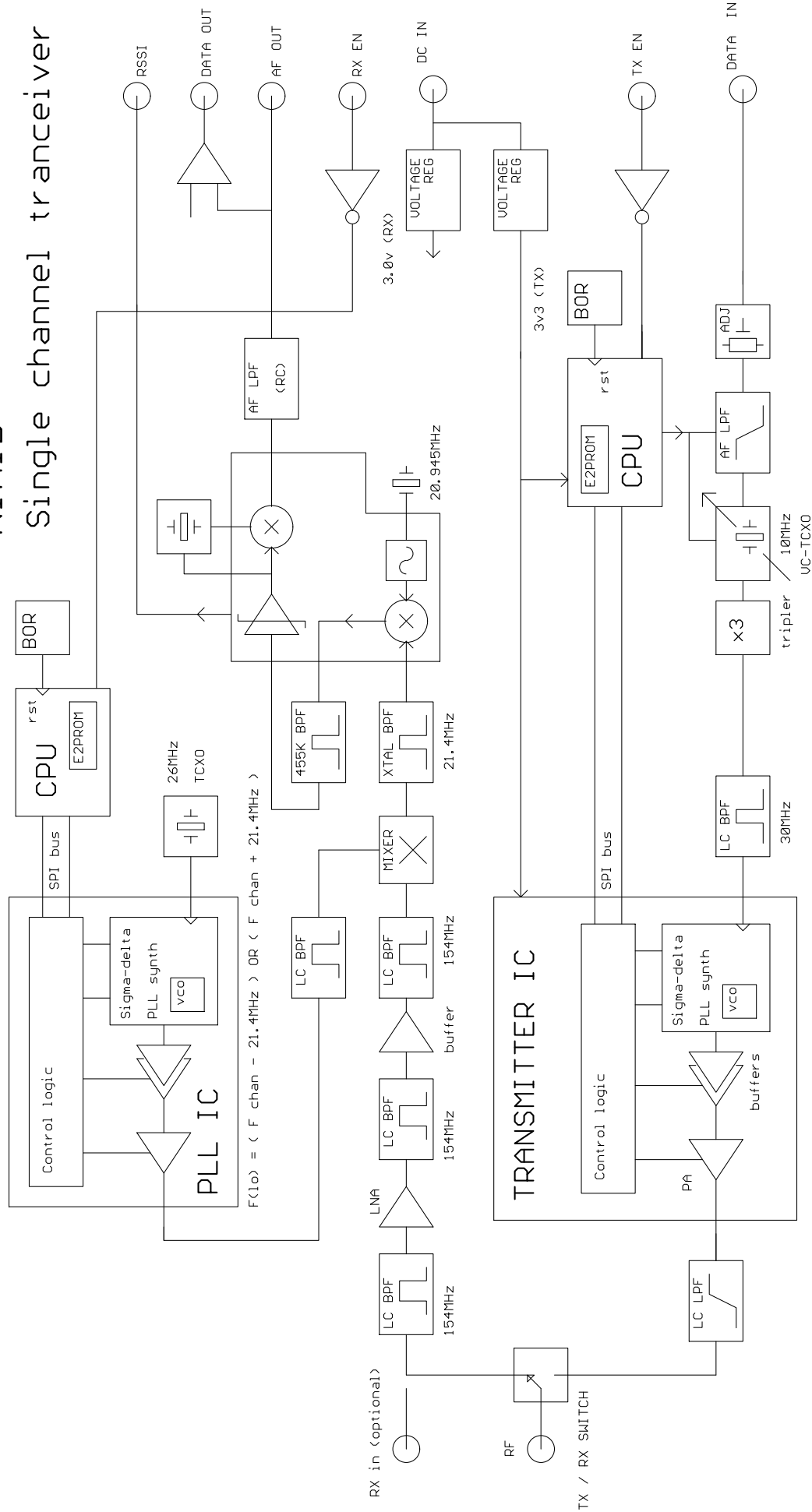

Figure 2: NiM1B schematics

Functional description

The transmit section of the NiM1B consists of a highly integrated sigma delta (fractional N) synthesizer based single chip RF device, configured over an SPI serial bus by an on-board microcontroller. The primary frequency reference for the transmitter is a 30MHz VC-TCXO. Modulation is applied directly to this reference via an AF baseband filter (rather than using the chip's internal modulator) to permit a wider range of baseband data rates and waveforms. Operation is controlled by the N_TXE line, the transmitter achieving full RF output typically within 5ms of this line being pulled low. The RF output is filtered to ensure compliance with the appropriate radio regulations and fed to the 50Ω antenna pin.

The receiver section of the NiM1B consists of a highly integrated sigma delta (fractional N) synthesizer based Local Oscillator (LO), configured over an SPI serial bus by an on-board microcontroller. The primary frequency reference for the LO is a 26MHz TCXO. The remainder of the receiver is a conventional dual conversion super-heterodyne, using a wide dynamic range dual gate mosfet mixer and crystal / ceramic filter elements for optimum performance. The RF input is filtered using a multi-stage LC filter in the front end to provide image rejection and enhanced blocking performance. This reduces the user programmable frequency range to the filter passband, but can easily be re-banded (in the factory) to other frequencies.

User interface

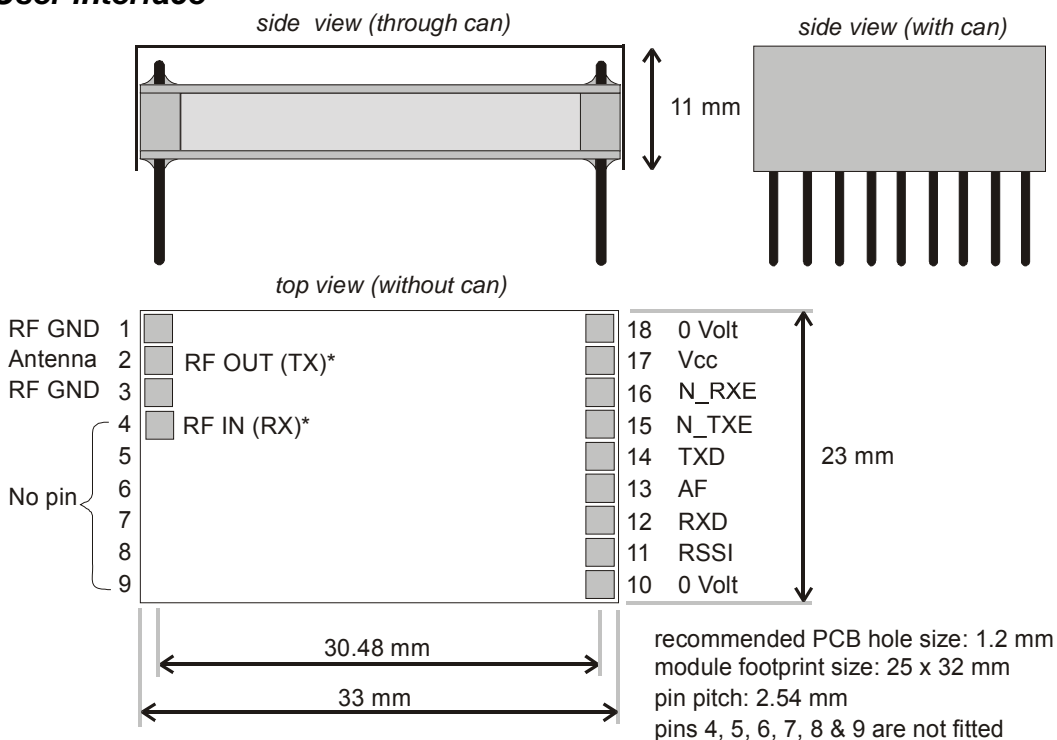

Figure 3: NiM1B pin-out and dimension

NiM1B Pin	Name	Function
1, 3, 10, 18	0V	Ground
17	VCC	3.3 – 15V DC power supply
16	N_RXE / RX PGM	Pull low to enable Receiver / receive programming in put
15	N_TXE / TX PGM	Pull low to enable Transmitter / transmit programming in put
14	TXD	DC coupled input for 3V CMOS logic. $R_{in} = 100k\Omega$
13	AF	500mV _{pk-pk} audio. DC coupled, approx 1.5V bias
12	RXD	Open collector output, with a 10kΩ pullup to Vcc. Suitable for Biphase codes
11	RSSI	DC level between 0.5V and 2V. 50dB dynamic range

NOTES:

1. N_Rxe and N_Txe have (10K approx.) pullups to +Vin
2. Unit is programmable (in much the same way as an NTX2B or NRX2B) using the N_Rxe or N_Txe pins. Reprogramming requires a 0v to +Vin logic level non-inverted RS232 data-stream to pin 3 or 4. Alternatively, an RS232 port can be directly connected to the enable pin for programming, without risk.
3. Avoid N_Rxe and N_Txe both low: undefined module operation may occur (but damage will not result)
4. Pinout is as BiM1. On RF connector end only pins 1,2,3 are present (*except for NiM1B with separate RX and TX ports which has 4 pins. See ordering info (p12) for further details on this special build).
5. Switching time as controlled by N_Txe or N_Rxe pins is <5mS, but when power is first applied to the unit there is a 20mS long "calibration" period before the transmitter becomes active. If the rail is switched (as opposed to the EN pins) then this should be considered as a 25mS device

Absolute maximum ratings

Exceeding the values given below may cause permanent damage to the module.

Operating temperature	-20°C to +70°C
Storage temperature	-30°C to +85°C
RF in (pin 1)	±50V @ <10MHz, +13dBm @ >10MHz
All other pins	-0.3V to +15.0V

Performance specifications:

(Vcc = 5V / temperature = 20°C unless stated)

General	pin	min.	typ.	max.	units	notes
DC supply						
Supply voltage	17	3.3	-	15	V	
TX Supply current (20mW)	17		30		mA	
RX Supply current	17		18		mA	
Antenna pin impedance	2		50		Ω	
RF centre frequency			154.570 / 154.600		MHz	1
Channel spacing			25		kHz	
Number of channels			1			1
Transmitter						
RF						
RF power output	2	+12	+13	+14	dBm	2
Spurious emissions	2		-50		dBm	3
Adjacent channel TX power			-37		dBm	
Frequency accuracy			±1.5 (5ppm)		kHz	4
FM deviation (peak)		±2.5	±3.0	±3.5	kHz	5
Baseband						
Modulation bandwidth @ -3dB		0		3.5	kHz	DC coupled
TXD input level (logic low)	14		0		V	6
TXD input level (logic high)	14		3.0		V	6
Dynamic timing						
TX select to full RF				5	ms	
Receiver						
RF/IF						
RF sensitivity @ 12dB SINAD	2, 13		-120		dBm	
RF sensitivity @ 1ppm BER	2, 12		-112		dBm	
RSSI range	2, 11	50	50		dB	7
Blocking	2		84		dB	
Image rejection	2		70		dB	
Adjacent channel rejection	2	63			dB	3
Spurious response rejection	2		70		dB	
LO leakage, radiated				-70	dBm	4
Baseband						
Baseband bandwidth @ -3dB	13		5		kHz	
AF level	13		500		mV _{P-P}	8
DC offset on AF out	13		1.5		V	
Distortion on recovered AF	12		5		%	

General	pin	min.	typ.	max.	units	notes
Dynamic timing						
<i>RX enable with signal present</i>						
N_RXE active (low) to stable AF output	16, 13		10			
N_RXD active (low) to stable RXD output	16, 12		25		ms	
<i>Signal applied with receiver enabled</i>						
Signal to valid AF	2, 11		10		ms	
Signal to stable data	2, 12		25		ms	

Notes:

1. Programs to any 154MHz MURS 25kHz bandwidth frequencies
2. Measured into 50Ω resistive loads.
3. Exceeds EN/EMC requirements at all frequencies.
4. 5ppm TCXO. Total over full supply and temperature range.
5. With 0V – 3.0V modulation input.
6. To achieve specified FM deviation.
7. See applications information for further details.
8. For received signal with ±3kHz FM deviation.

Channel Programming

At the heart of the device is a fractional N synthesizer locked to a high stability VCXO. The minimum step size of this PLL is (approximately) 4.8Hz

The data required by the PLL consists of two coefficients: the integer (INTE) and the fraction (FRAC). Output frequency relates to these values thus:

$$Freq = \left(INTE + \frac{FRAC}{2^{19}} \right) \times \frac{2 \times VCTCXO}{Outdiv} \quad \text{where} \quad \frac{2 \times 30MHz}{24} = 2.5MHz$$

NiM1B uses 30MHz VCTCXO and the Output Divider (Outdiv) value for 140MHz - 175MHz band is 24 (corresponding to a programmed "band" value of 0x0D. See page 7)

For correct operation, the component (FRAC / 2¹⁹) must have a value between 1 and 2

$$Freq = \left(INTE + \frac{FRAC}{2^{19}} \right) \times 2.5 \quad 1 \leq \frac{FRAC}{2^{19}} \leq 2 \quad 524,288 \leq FRAC \leq 1,048,576$$

$$INTE = WholeNum \left[\frac{Freq}{2.5} \right] - 1 \quad FRAC = \left(DecimalNum \left[\frac{Freq}{2.5} \right] + 1 \right) \times 524288$$

In interface terms, these coefficients are expressed as a 32-bit binary word (eight hexadecimal digits) where the most significant byte comprises the integer value, and the remaining three bytes (24 bits) make up the "fraction"

TX Example: $\frac{154.570MHz}{2.5MHz} = 61.828$

INTE = 61-1 = 60 (0x3C)
FRAC = (0.828 + 1) × 524288 = 958398 (0x0E9FB E)
FRAC2 = 0x0E
FRAC1 = 0x9F
FRAC0 = 0xBE

$$Freq = \left(60 + \frac{958398}{524288} \right) \times 2.5 = 154.569998MHz = 154.570MHz - 2.21Hz$$

However, the frequency programmed into the receiver section is the LOCAL OSCILLATOR (LO) frequency, not the actual channel frequency, and the reference frequency is 26MHz rather than 30MHz, so some of the calculations are also different (For example, the minimum step size is approximately 4.1Hz)

For unit operating on a channel frequency of 163MHz or higher, the local oscillator is 21.4MHz below the carrier (so subtract 21.4MHz). AF output will be inverted on higher receive frequency units.

$$LO = RF - IF = 173.250\text{MHz} - 21.4\text{MHz} = 151.85\text{MHz} \quad \text{for } RF \geq 163\text{MHz}$$

For units operating on frequencies below 156MHz, the local oscillator is 21.4MHz above the channel.

$$LO = RF + IF = 154.700\text{MHz} + 21.4\text{MHz} = 176.100\text{MHz} \quad \text{for } RF < 156\text{MHz}$$

Receivers operating between 156 and 163MHz (and transmitters below 142MHz) are a special case. These are fitted with a different LO chip (an Si4464 instead of an Si4060), which has a coverage of 119 to 159MHz, allowing conventional low side injection to be maintained

RX Example: $\frac{154.570\text{MHz} + 21.4\text{MHz}}{2.5\text{MHz}} = 70.388$

$$\begin{aligned} INTE &= 70-1 = 69 \text{ (0x45)} \\ FRAC &= (0.388 + 1) \times 524288 = 727712 \text{ (0x0B1AA0)} \\ FRAC2 &= 0x0B \\ FRAC1 &= 0x1A \\ FRAC0 &= 0xA0 \end{aligned}$$

$$Freq = \left(69 + \frac{727712}{524288} \right) \times 2.5 = 175.9700012\text{MHz} = 175.970\text{MHz} + 1.2\text{Hz}$$

When programming the NiM1B, keep in mind that the unit maintains in SRAM the current values of all programmable values (frequency, band of operation, RF power and frequency offset adjustments values) and that toggling the PGM pin does NOT erase or corrupt them.

These values are only loaded from EEPROM at cold start power-up (but not when the relevant N_TXE or N_RXE pins are cycled)

There is one "write all values to EEPROM" command. It is usually necessary to load the relevant current operating RAM value(s) and THEN issue a suitable command to write the RAM value to EEPROM.

The NiM1B stores Frequency coefficients (for transmit and receive), frequency Offsets, band select and TX RF Power level constants in internal EPROMs.

ALWAYS REMEMBER THAT THE TRANSMIT AND RECEIVE SECTIONS OF THE NiM1B ARE INDEPENDANT, AND ARE PROGRAMMED ENTIRELY SEPARATELY.

No command sent to the transmitter will have any effect on the receiver, and vice-versa.

For the NiM1B RX section, power level should always be set to 3

Programming a value or coefficient over the serial bus over-writes the previous value and implements this change on the PLL immediately, but does not change the EEPROM contents until a relevant "program EEPROM" command is issued

In general, the most recent stimulus received by the unit will decide the operating frequency. Whenever a frequency coefficient is programmed into the unit, the frequency will change immediately to this new value regardless of other modes or operation. This is the simplest and most flexible means of controlling the unit.

Serial interface commands

NiM1B is programmable (in the same way as an NTX2B or NRX2B, or a NiM2B) using the N_Rxe or N_Txe pins. Reprogramming requires a 0v to +Vin logic level non-inverted RS232 data-stream to pin 3 (RX PGM) or 4 (TX PGM). An RS232 port can be directly connected to the enable pin for programming.

The serial data should be in the following format: 9600bps, 8 data bits, No Parity, 1 Stop

Every command string starts with the phrase "@PRG_" and terminated with Carriage Return <cr>.

The characters in a command string must not be separated by more than 5ms (so typing individual characters on a terminal keyboard will NOT work), but a pause of at least 10ms is required between commands (more following a BURN_ROM command. In this case a much longer idle period, of 50mS at least, is needed for EEPROM programming)

User commands

Commands	Function
@PRG_iif2f1f0<cr>	sets the transmitter / receiver frequency iif2f1f0 is an 8 digit hexadecimal number, coding 4 bytes: ii is the "integer" value f2 most significant FRAC2 byte in the 24 bit FRAC word f1 bits 8 through 15 of the fraction word (FRAC1) f0 least significant FRAC0 byte e.g. @PRG_3C0E9FBE<cr> to program 154.570MHz (@PRG_450B1AA0 <cr> for receiver)
@PRG_BURN_ROM<cr>	write current setup into EEPROM
@PRG_POWER 00<cr> @PRG_POWER FF<cr>	Turn the unit completely OFF (power down) Turn the unit ON (power up) TX /RX PGM pin can also be cycled
@PRG_00000000<cr>	Re-sets itself to the values currently stored in EEPROM (this usually only happens at power-up)

Factory alignment commands

Commands	Function
@PRG_POWER pp <cr>	Sets the RF Power output pp is a 2 digit hexadecimal number (in the range 00 to 3F) 00 - power OFF, FF – power ON e.g. @PRG_POWER 32<cr>
@PRG_TRIM+ aa <cr>	set an "up" offset aa is 00 (0Hz) to 7F (+610Hz) at 4.8Hz per bit (TX) eg. @PRG_TRIM+1E<cr> (4.1Hz for RX)
@PRG_TRIM- aa <cr>	sets a "down" offset aa is 00 (0Hz) to 7F (-610Hz) at 4.8Hz per bit (TX) (4.1Hz for RX)
@PRG_BAND# bb	band divider value (bb) 08 850-1050MHz 0A 425-520MHz 0B 280-350MHz 0D 140-175MHz e.g. PRG_BAND# 0A<cr>
@PRG_BURN_ROM<cr>	write current setup into EEPROM

Applications information

Power supply requirements

The NiM1B have built-in regulators, which deliver a constant 3.3V to the transmitter and the receiver circuitry when the external supply voltage exceeds 3.3V. This ensures constant performance up to the maximum permitted rail, and removes the need for external supply decoupling, except in cases where the supply rail is extremely poor (ripple/noise content >0.1Vp-p). The unit will continue to function with a 3v supply, but power output will fall

TX modulation requirements

The module is factory-set to produce the specified FM deviation with a TXD input to pin 14 of 3V amplitude, i.e. 0V "low", 3V "high"

If the data input level is greater than 3V, a resistor must be added in series with the TXD input to limit the modulating input voltage to a maximum of around 3V on pin 14. TXD input resistance is 100k Ω to ground, giving typical required resistor values as follows:

Vcc	Series resistor
$\leq 3V$	-
3.3V	10 k Ω
5V	68k Ω
9V	220k Ω

RX Received Signal Strength Indicator (RSSI)

The NiM1B wide range RSSI which measures the strength of an incoming signal over a range of 50dB or more. This allows assessment of link quality and available margin and is useful when performing range tests.

The output on pin 11 of the module has a standing DC bias of up to 0.5V (approx.) with no signal, rising to around 2.0V at maximum indication. (Vmin-Vmax) is typically 1V and is largely independent of standing bias variations. Output impedance is 56k Ω . Pin 11 can drive a 100 μ A meter directly, for simple monitoring.

Please note that the actual RSSI voltage at any given RF input level varies somewhat between units. The RSSI facility is intended as a relative indicator only - it is not designed to be, or suitable as, an accurate and repeatable measure of absolute signal level or transmitter-receiver distance.

Typical RSSI characteristic is as shown below:

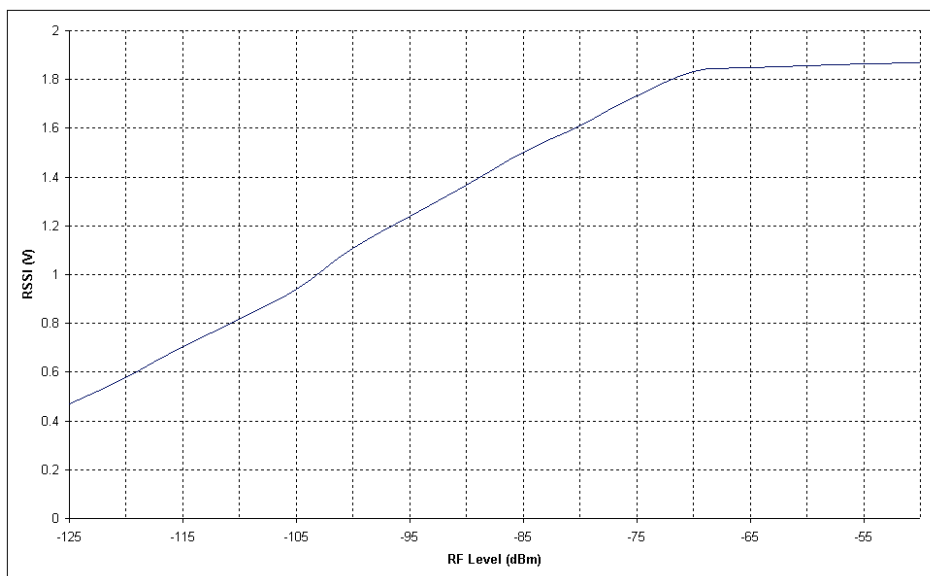

Figure 4: RSSI level with respect to received RF level at NiM1B antenna pin

Expected range

Predicting the range obtainable in any given situation is notoriously difficult since there are many factors involved. The main ones to consider are as follows:

- Type and location of antennas in use
- Type of terrain and degree of obstruction of the link path
- Sources of interference affecting the receiver
- “Dead” spots caused by signal reflections from nearby conductive objects
- Data rate and degree of filtering employed

The following are typical examples – but range tests should always be performed before assuming that a particular range can be achieved in a given situation:

Data rate	Tx antenna	Rx antenna	Environment	Range
5kbps	half-wave	half-wave	rural/open	3-4km
5kbps	helical	half-wave	urban/obstructed	500m-1km
5kbps	helical	helical	in-building	100-200m

The NiM1B TXD input is normally driven directly by logic signals, but will also accept analogue drive (e.g. 2-tone signalling). In this case the TXD pin can either be directly DC driven with a 3v pp waveform with a 1.5v centre point, or a 3v pp signal can be AC coupled (when the input circuits will self-bias to 1.5v). Do not exceed 3v pp, or the baseband waveform will begin to clip. The VC-TCXO in the NiM1B is highly linear, and tx distortion figures well under 5% should be seen. At the other end of the link the NiM1B AF output (or the RXD pin) may be used to drive an external decoder or other signal processing circuitry.

Although the modulation bandwidth of the NiM1B extends down to DC it is not advisable to use data containing a DC component. This is because frequency errors and drifts between the transmitter and receiver occur in normal operation, resulting in DC offset errors on the NiM1B audio output.

The NiM1B in standard form incorporates a low pass filter with a 3.5kHz nominal bandwidth. This is suitable for transmission of data at raw bit rates up to 5kbps.

In applications such as long range fixed links where data speed is not of prime concern, a considerable increase in range can be obtained by using the slowest possible data rate together with filtering to reduce the receiver bandwidth to the minimum necessary.

Antennas

The choice and positioning of transmitter and receiver antennas is of the utmost importance and is the single most significant factor in determining system range. The following notes are intended to assist the user in choosing the most effective antenna type for any given application.

Integral antennas

These are relatively inefficient compared to the larger externally-mounted types and hence tend to be effective only over limited ranges. They do however result in physically compact equipment and for this reason are often preferred for portable applications. Particular care is required with this type of antenna to achieve optimum results and the following should be taken into account:

1. Nearby conducting objects such as a PCB or battery can cause detuning or screening of the antenna which severely reduces efficiency. Ideally the antenna should stick out from the top of the product and be entirely in the clear, however this is often not desirable for practical/ergonomic reasons and a compromise may need to be reached. If an internal antenna must be used try to keep it away from other metal components and pay particular attention to the “hot” end (i.e. the far end) as this is generally the most susceptible to detuning. The space around the antenna is as important as the antenna itself.
2. Microprocessors and microcontrollers tend to radiate significant amounts of radio frequency hash which can cause desensitisation of the receiver if its antenna is in close proximity. The problem becomes worse as logic speeds increase, because fast logic edges generate harmonics across the VHF range which are then radiated effectively by the PCB tracking. In extreme cases system range may be reduced by a factor of 5 or more. To minimise any adverse effects situate antenna and module as far as possible

from any such circuitry and keep PCB track lengths to the minimum possible. A ground plane can be highly effective in cutting radiated interference and its use is strongly recommended.

A simple test for interference is to monitor the receiver RSSI output voltage, which should be the same regardless of whether the microcontroller or other logic circuitry is running or in reset.

The following types of integral antenna are in common use:

Quarter-wave whip. This consists simply of a piece of wire or rod connected to the module at one end. At 151MHz the total length should be 471mm from module pin to antenna tip including any interconnecting wire or tracking. Because of the length of this antenna it is almost always external to the product casing.

Helical. This is a more compact but slightly less effective antenna formed from a coil of wire. It is very efficient for its size, but because of its high Q it suffers badly from detuning caused by proximity to nearby conductive objects and needs to be carefully trimmed for best performance in a given situation. The size shown is about the maximum commonly used at 151MHz and appropriate scaling of length, diameter and number of turns can make individual designs much smaller.

Loop. A loop of PCB track having an inside area as large as possible (minimum about 5cm²), tuned and matched with 2 capacitors. Loops are relatively inefficient but have good immunity to proximity detuning, so may be preferred in shorter range applications where high component packing density is necessary.

Integral antenna summary:

	whip	helical	loop
Ultimate performance	***	**	*
Ease of design set-up	***	**	*
Size	*	***	**
Immunity to proximity effects	**	*	***

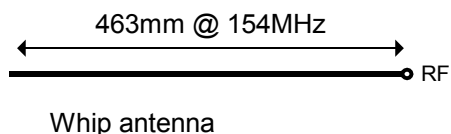

wire, rod, PCB track
or a combination of these
length(mm) = 71250 / freq(MHz)

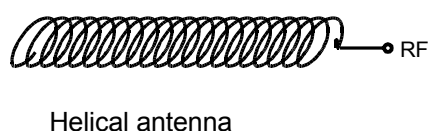

35-40 turns wire spring
length 120mm, dia 10mm
trim wire length or expand coil
for best results

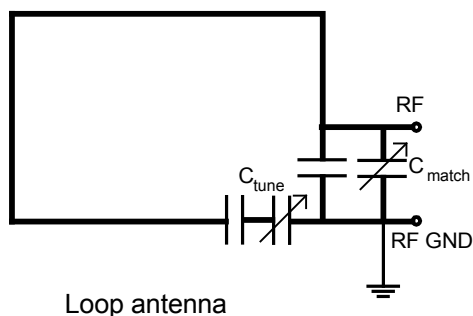

track width = 1mm
min. area 500mm²
capacitors may be variable or fixed
(values depend on loop dimensions)

Figure 5: integral antenna configurations

External antennas

These have several advantages if portability is not an issue, and are essential for long range links. External antennas can be optimised for individual circumstances and may be mounted in relatively good RF locations away from sources of interference, being connected to the equipment by coax feeder.

Helical. Of similar dimensions and performance to the integral type mentioned above, commercially-available helical antennas normally have the coil element protected by a plastic moulding or sleeve and incorporate a coax connector at one end (usually a straight or right-angle BNC type). These are compact

and simple to use as they come pre-tuned for a given application, but are relatively inefficient and are best suited to shorter ranges.

Quarter-wave whip. Again similar to the integral type, the element usually consists of a stainless steel rod or a wire contained within a semi-flexible moulded plastic jacket. Various mounting options are available, from a simple BNC connector to wall brackets, through-panel fixings and magnetic mounts for temporary attachment to steel surfaces.

A significant improvement in performance is obtainable if the whip is used in conjunction with a metal ground plane. For best results this should extend all round the base of the whip out to a radius of 300mm or more (under these conditions performance approaches that of a half-wave dipole) but even relatively small metal areas will produce a worthwhile improvement over the whip alone. The ground plane should be electrically connected to the coax outer at the base of the whip. Magnetic mounts are slightly different in that they rely on capacitance between the mount and the metal surface to achieve the same result.

A ground plane can also be simulated by using 3 or 4 quarter-wave radials equally spaced around the base of the whip, connected at their inner ends to the outer of the coax feed. A better match to a 50Ω coax feed can be achieved if the elements are angled downwards at approximately 30-40° to the horizontal.

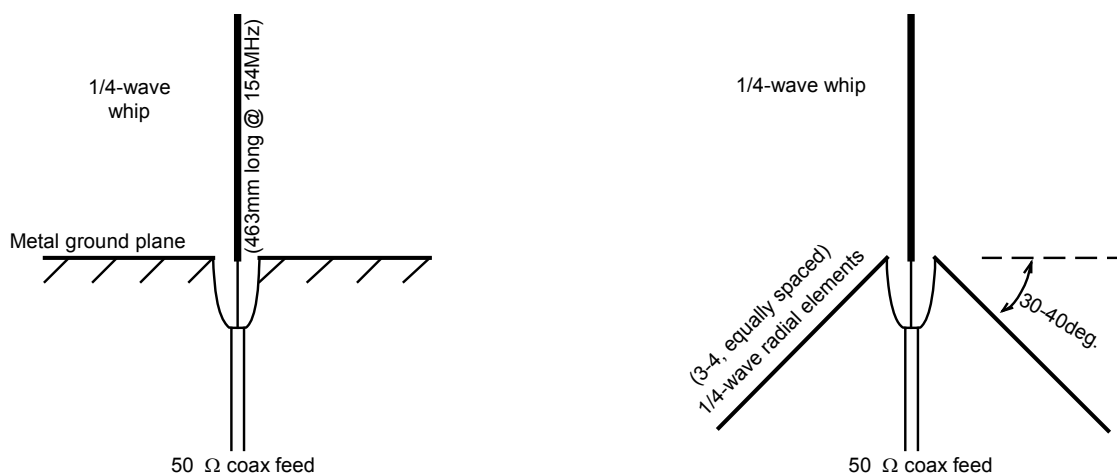

Fig.6: Quarter wave antenna / ground plane configurations

Half-wave. There are two main variants of this antenna, both of which are very effective and are recommended where long range and all-round coverage are required:

1. The half-wave dipole consists of two quarter-wave whips mounted in line vertically and fed in the centre with coaxial cable. The bottom whip takes the place of the ground plane described previously. A variant is available using a helical instead of a whip for the lower element, giving similar performance with reduced overall length. This antenna is suitable for mounting on walls etc. but for best results should be kept well clear of surrounding conductive objects and structures (ideally >1m separation).
2. The end-fed half wave is the same length as the dipole but consists of a single rod or whip fed at the bottom via a matching network. Mounting options are similar to those for the quarter-wave whip. A ground plane is sometimes used but is not essential. The end-fed arrangement is often preferred over the centre-fed dipole because it is easier to mount in the clear and above surrounding obstructions.

Yagi. This antenna consists of two or more elements mounted parallel to each other on a central boom. It is directional and exhibits gain but tends to be large and unwieldy – for these reasons the yagi is the ideal choice for links over fixed paths where maximum range is desired.

Please note: Using a Yagi or other gain antenna with the NiM1B will exceed the maximum radiated power permitted by UK type approval regulations. It can be used in the UK only in conjunction with the NiM1BR receiver.

For best range, in fixed link applications use a half-wave antenna on NiM1BT transmitter and a half-wave or Yagi on NiM1BR receiver, both mounted as high as possible and clear of obstructions.

Good RF layout practice should be observed. If the connection between module and antenna is more than about 20mm long use 50Ω microstrip line or coax or a combination of both. It is desirable (but not essential) to fill all unused PCB area around the module with ground plane.

Module mounting considerations

Good RF layout practice should be observed. If the connection between module and antenna is more than about 20mm long use 50Ω microstrip line or coax or a combination of both. It is desirable (but not essential) to fill all unused PCB area around the module with ground plane.

Variants and ordering information

The NiM1BT transmitters, NiM1BR receivers and NiM1B transceivers are manufactured in the following variants as standard:

At 154.570MHz:	NiM1B-154.570-5	Transceiver
	NiM1BT-154.570-5	Transmitter
	NiM1BR-154.570-5	Receiver
At 154.600MHz:	NiM1B-154.600-5	Transceiver
	NiM1BT-154.600-5	Transmitter
	NiM1BR-154.600-5	Receiver

(Depending on the built state, NiM1B can be reprogrammed on any frequencies with in the 120 - 175MHz band)

NiM1B with separate TX and RX RF ports: NiM1B-154.570-5-TR

The NiM1B can be factory built with separate RX and TX ports.

This special built will have 4 pins on the RF connector instead of three (refer to figure 3)

- Pin 1 RF GND
- 2 RF OUT (TX)
- 3 RF GND
- 4 RF IN (RX)

The RF IN (RX) port MUST be externally AC coupled, as it has a bias voltage on it

This is useful if an application requires using an external TX power amp, RX pre-amp, or separate antennas TX and RX.

Radiometrix Ltd

**Hartcran House
231 Kenton Lane
Harrow, Middlesex
HA3 8RP
ENGLAND**

Tel: +44 (0) 20 8909 9595

Fax: +44 (0) 20 8909 2233

sales@radiometrix.com

www.radiometrix.com

Copyright notice

This product data sheet is the original work and copyrighted property of Radiometrix Ltd. Reproduction in whole or in part must give clear acknowledgement to the copyright owner.

Limitation of liability

The information furnished by Radiometrix Ltd is believed to be accurate and reliable. Radiometrix Ltd reserves the right to make changes or improvements in the design, specification or manufacture of its subassembly products without notice. Radiometrix Ltd does not assume any liability arising from the application or use of any product or circuit described herein, nor for any infringements of patents or other rights of third parties which may result from the use of its products. This data sheet neither states nor implies warranty of any kind, including fitness for any particular application. These radio devices may be subject to radio interference and may not function as intended if interference is present. We do NOT recommend their use for life critical applications.

The Intrastat commodity code for all our modules is: 8542 6000

R&TTE Directive

After 7 April 2001 the manufacturer can only place finished product on the market under the provisions of the R&TTE Directive. Equipment within the scope of the R&TTE Directive may demonstrate compliance to the essential requirements specified in Article 3 of the Directive, as appropriate to the particular equipment.

Further details are available on The Office of Communications (Ofcom) web site:

<http://www.ofcom.org.uk/>

Information Requests

Ofcom

Riverside House

2a Southwark Bridge Road

London SE1 9HA

Tel: +44 (0)300 123 3333 or 020 7981 3040

Fax: +44 (0)20 7981 3333

information.requests@ofcom.org.uk

European Communications Office (ECO)

Pebblinghus

Nansensgade 19

DK 1366 Copenhagen

Tel. +45 33896300

Fax +45 33896330

ero@ero.dk

www.ero.dk
