



TAI-SAW TECHNOLOGY CO., LTD.

No. 3, Industrial 2nd Rd., Ping-Chen Industrial District,
Taoyuan, 324, Taiwan, R.O.C.

TEL: 886-3-4690038 FAX: 886-3-4697532

E-mail: tstsales@mail.taisaw.com Web: www.taisaw.com

Product Specifications Approval Sheet

Product Description: SAW Filter 2593 MHz Band 41 TRX SMD 1.4x1.1 mm (BW=194 MHz)

TST Part No.: TA2326A

Customer Part No.: _____

Customer signature required
Company: _____
Division: _____
Approved by : _____
Date: _____

Checked by: _____ David Chang *David*

Approved by: _____ Andy Yu *Andy Yu*

Date: _____ 11/22/2017

1. Customer signed back is required before TST can proceed with sample build and receive orders.
2. Orders received without customer signed back will be regarded as agreement on the specifications.
3. Any specifications changes must be approved upon by both parties and a new revision of specifications shall be released to reflect the changes.



TAI-SAW TECHNOLOGY CO., LTD.

No. 3, Industrial 2nd Rd., Ping-Chen Industrial District,
Taoyuan, 324, Taiwan, R.O.C.

TEL: 886-3-4690038 FAX: 886-3-4697532

E-mail: tstsales@mail.taisaw.com Web: www.taisaw.com

SAW Filter 2593 MHz Band 41 TRX SMD 1.4x1.1 mm

MODEL NO.: TA2326A

REV. NO.:1

A. MAXIMUM RATING:

1. Maximum Input Power: 29 dBm, 5000h 50 °C
2. Maximum DC Voltage: 0 V
3. Operating temperature range: -10 °C to +85 °C
4. Storage temperature range: -40 °C to +85 °C
5. Moisture Sensitivity Level: Level 3(MSL3)

RoHS Compliant

Lead-free soldering

Electrostatic Sensitive Device (ESD)

B. ELECTRICAL CHARACTERISTICS:

Terminating source impedance: $Z_s = 50//1.6nH \Omega$ (Single-ended)

Terminating load impedance: $Z_L = 50//2.0nH \Omega$ (Single-ended)

Item	Unit	Min.	Typ.	Max.
Center Frequency Fc	MHz	-	2593	-
Insertion Loss (2496 ~ 2501 MHz)	dB	-	3.0	4.3
Insertion Loss (2501 ~ 2690 MHz)	dB	-	2.6	3.8
Insertion Loss (2500 ~ 2680 MHz)	dB	-	2.6	3.8
Insertion Loss (2680 ~ 2690 MHz)	dB	-	2.6	3.5
Insertion Loss (2555 ~ 2655 MHz)	dB	-	1.8	2.8
Insertion Loss (2545 ~ 2575 MHz)	dB	-	1.4	2.5
Insertion Loss (2620 ~ 2690 MHz)	dB	-	2.6	3.3
Amplitude Ripple (2496 ~ 2501 MHz)	dB _{p-p}	-	0.7	2.6
Amplitude Ripple (2501 ~ 2690 MHz)	dB _{p-p}	-	1.3	2.4
VSWR (2496 ~ 2501 MHz)	-	-	1.4	2.0
VSWR (2501 ~ 2690 MHz)	-	-	1.6	2.0
Attenuation (reference level from 0 dB)				
DC ~ 916 MHz	dB	40	46	-
925 ~ 960 MHz	dB	37	44	-
1226.57 ~ 1228.63 MHz	dB	27	37	-
1242.42 ~ 1249.14 MHz	dB	27	36	-

1248 ~ 1564 MHz	dB	22	28	-
1559 ~ 1605.89 MHz	dB	22	28	-
1615 ~ 2400 MHz	dB	12	16	-
1710 ~ 1785 MHz	dB	17	23	-
1805 ~ 1850 MHz	dB	17	21	-
1880 ~ 1920 MHz	dB	17	20	-
1920 ~ 1980 MHz	dB	13	18	-
2110 ~ 2170 MHz	dB	10	14	-
2401 ~ 2468 MHz	dB	20	35	-
2451 ~ 2473 MHz	dB	7	25	-
2456 ~ 2478 MHz	dB	4	11	-
2461 ~ 2483 MHz	dB	3	6.7	-
2775 ~ 4992 MHz	dB	15	19	-
4992 ~ 5380 MHz	dB	25	33	-
5381 ~ 7487 MHz	dB	25	37	-
7488 ~ 8070 MHz	dB	25	38	-

C. OUTLINE DRAWING:

top view

bottom view

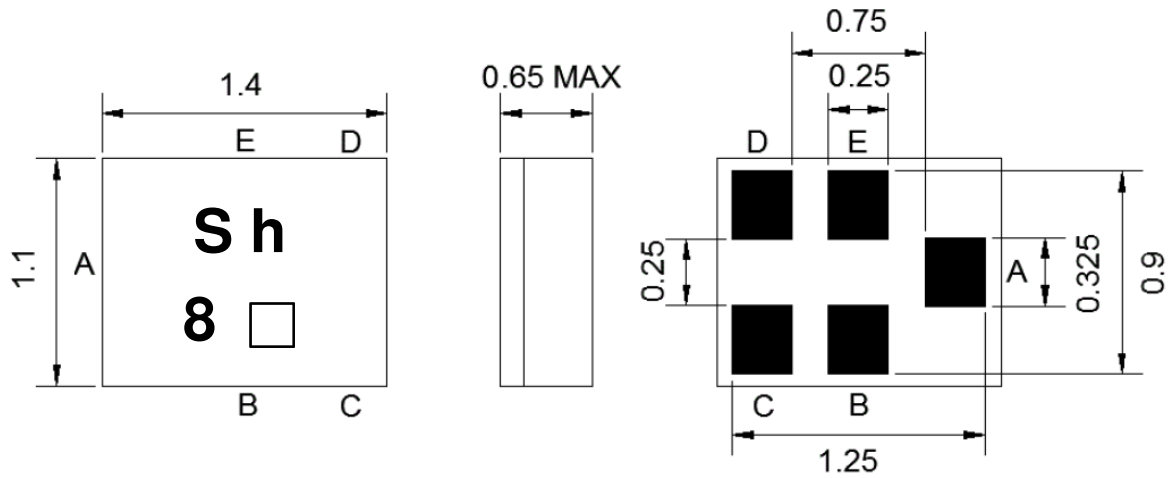

Pin Description	
B, C, E	Ground
A	Input
D	Output

Marking Descriptions	
□	Date Code(Year+Month)

□ : Year/Month Code (Follow the table)

YEAR/Month	1	2	3	4	5	6	7	8	9	10	11	12
2013	A	B	C	D	E	F	G	H	J	K	L	M
2014	N	P	Q	R	S	T	U	V	W	X	Y	Z
2015	a	b	c	d	e	f	g	h	j	k	l	m
2016	n	p	q	r	s	t	u	v	w	x	y	z
2017	<u>A</u>	<u>B</u>	<u>C</u>	<u>D</u>	<u>E</u>	<u>F</u>	<u>G</u>	<u>H</u>	<u>J</u>	<u>K</u>	<u>L</u>	<u>M</u>
2018	<u>N</u>	<u>P</u>	<u>Q</u>	<u>R</u>	<u>S</u>	<u>T</u>	<u>U</u>	<u>V</u>	<u>W</u>	<u>X</u>	<u>Y</u>	<u>Z</u>
2019	<u>a</u>	<u>b</u>	<u>c</u>	<u>d</u>	<u>e</u>	<u>f</u>	<u>g</u>	<u>h</u>	<u>j</u>	<u>k</u>	<u>l</u>	<u>m</u>
2020	<u>n</u>	<u>p</u>	<u>q</u>	<u>r</u>	<u>s</u>	<u>t</u>	<u>u</u>	<u>v</u>	<u>w</u>	<u>x</u>	<u>y</u>	<u>z</u>

D. MEASUREMENT CIRCUIT:

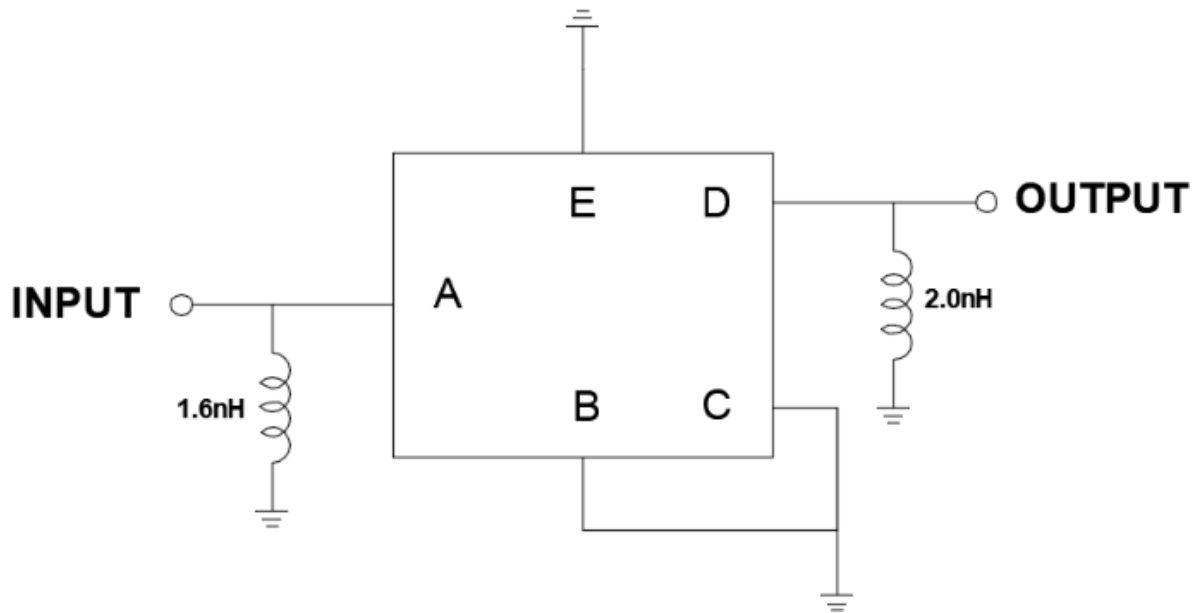

Source & Load Impedance: 50 Ω

E. PCB Footprint :

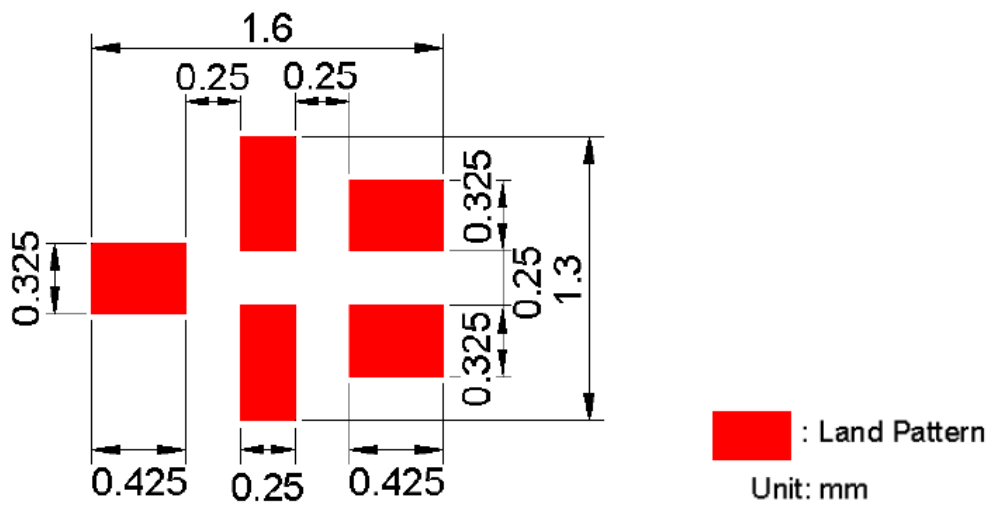

F. Frequency Characteristics:

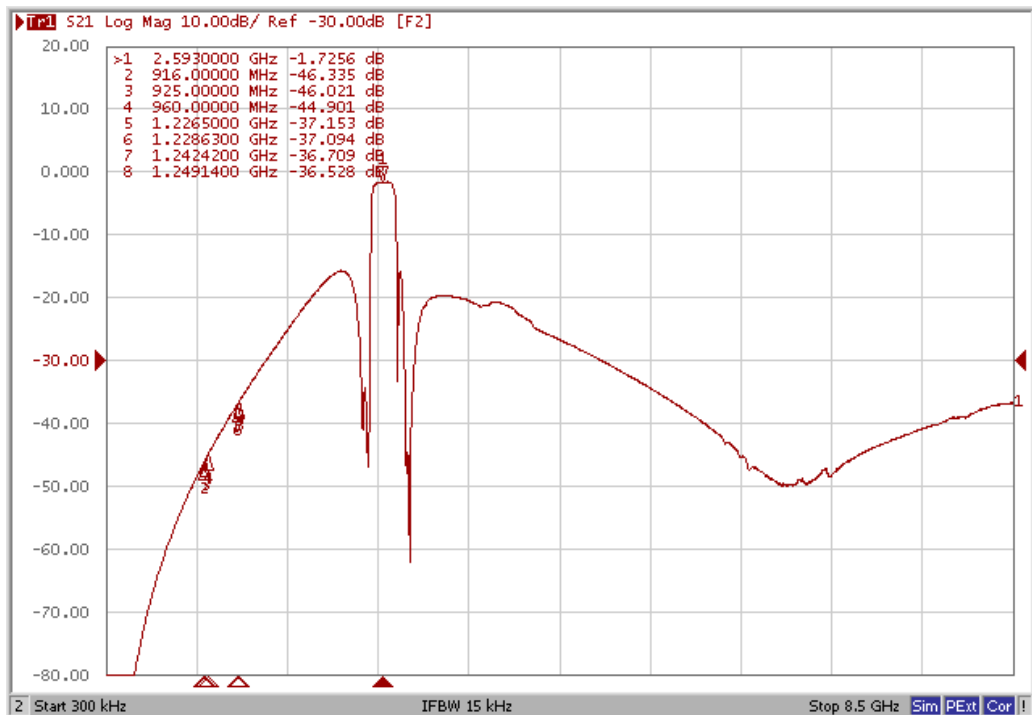
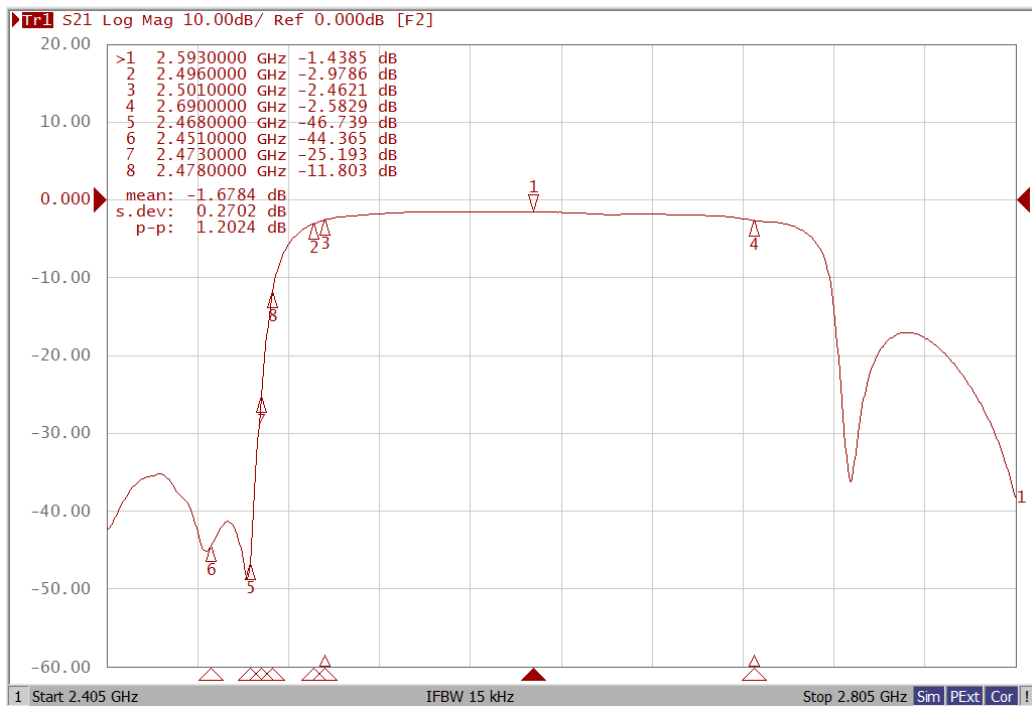

Reflection Functions:

VSWR

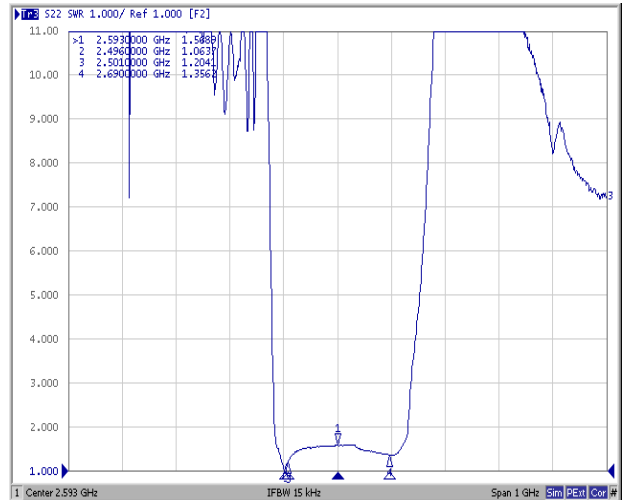
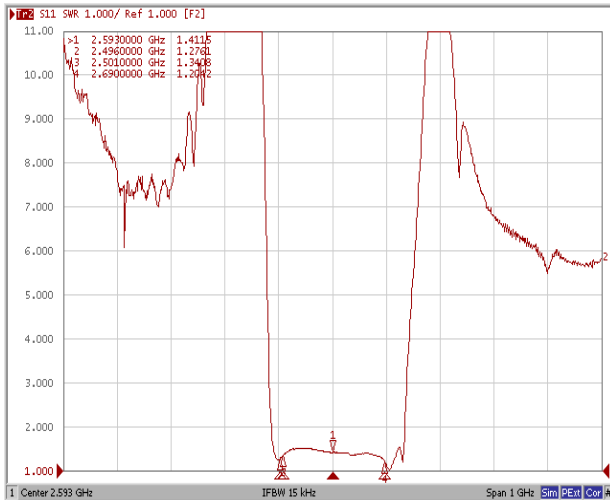

Smith Chart

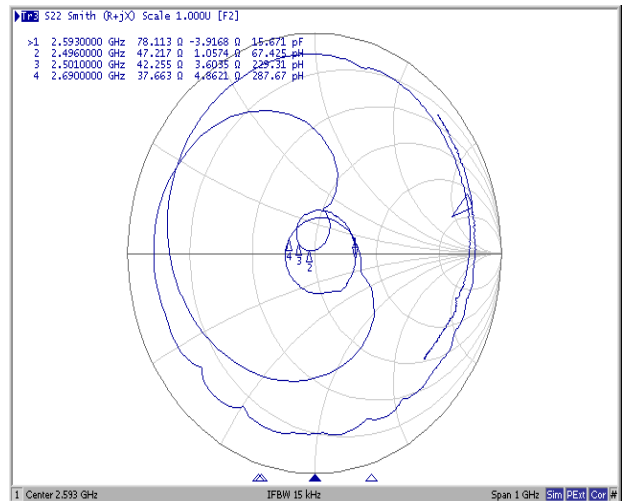
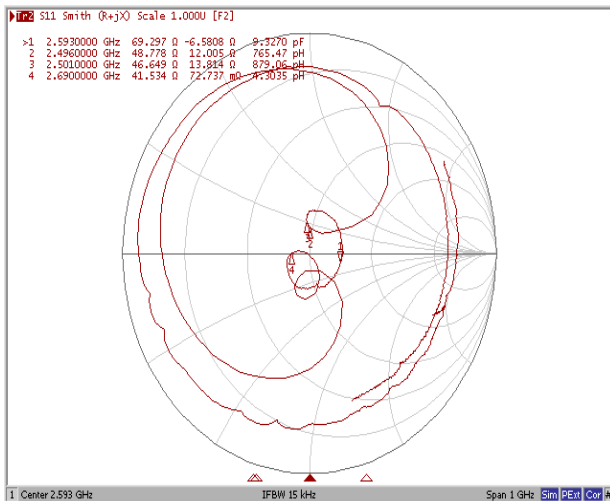

G. PACKING: (Ref. WI-75M03)

1. REEL DIMENSION

(Please refer to FR-75D10 for packing quantity)

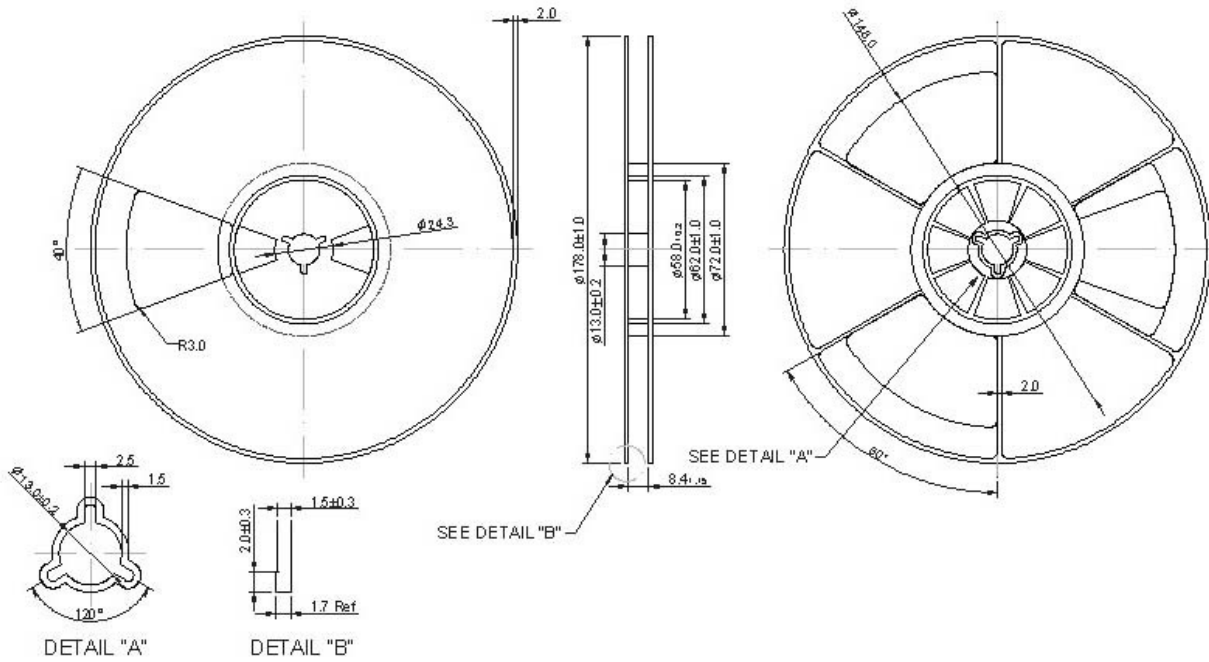

2. TAPE DIMENSION

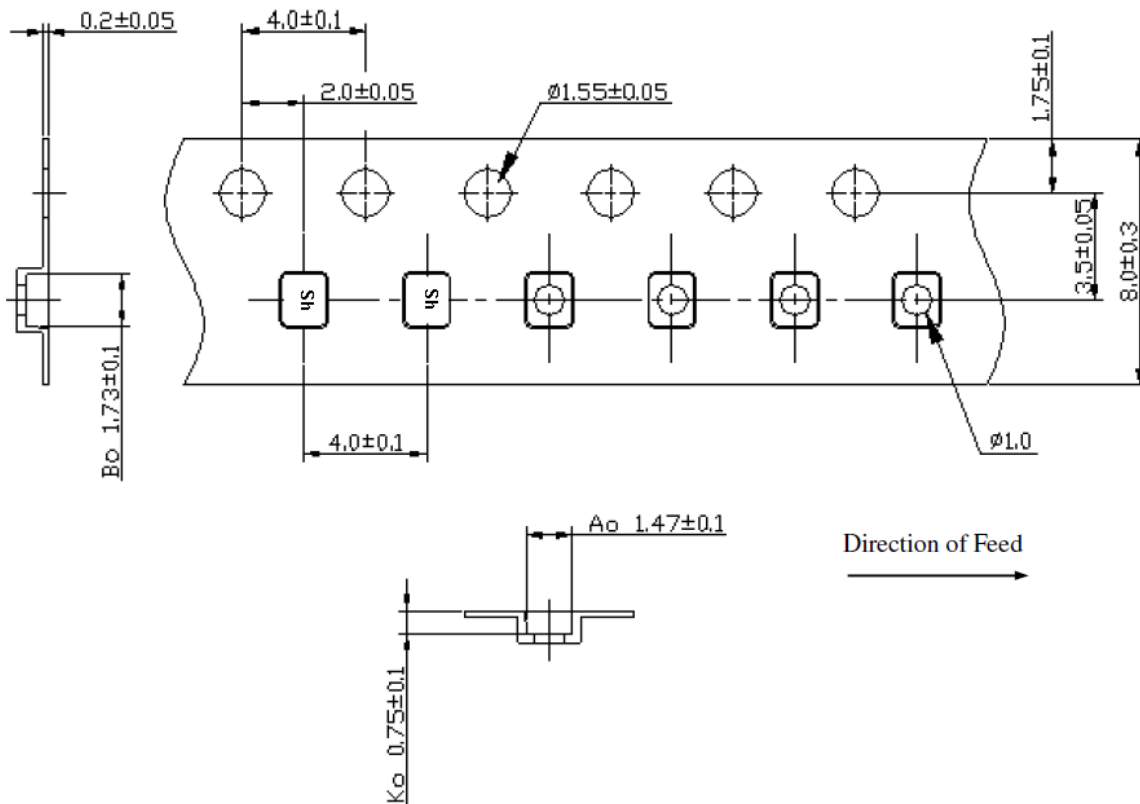

H. RECOMMENDED REFLOW PROFILE:

1. Preheating shall be fixed at 150~180°C for 60~90 seconds.
2. Ascending time to preheating temperature 150°C shall be 30 seconds min.
3. Heating shall be fixed at 220°C for 50~80 seconds and at 245~260°C peak (min. 10sec).
4. Time: 2 times.

