

UNCONTROLLED DOCUMENT

PART NUMBER		REV.
SSI-LXR3612BID-150		A
REV.	E.C.N. NUMBER AND REVISION COMMENTS	DATE
A	E.C.N. #10BRDR. & REDRAWN IN 3D.	1.4.02

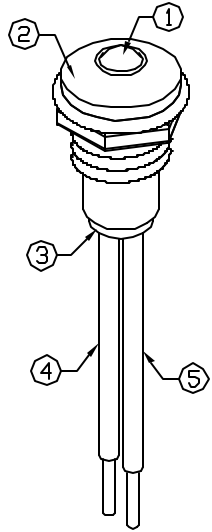

PANEL CUTOUT

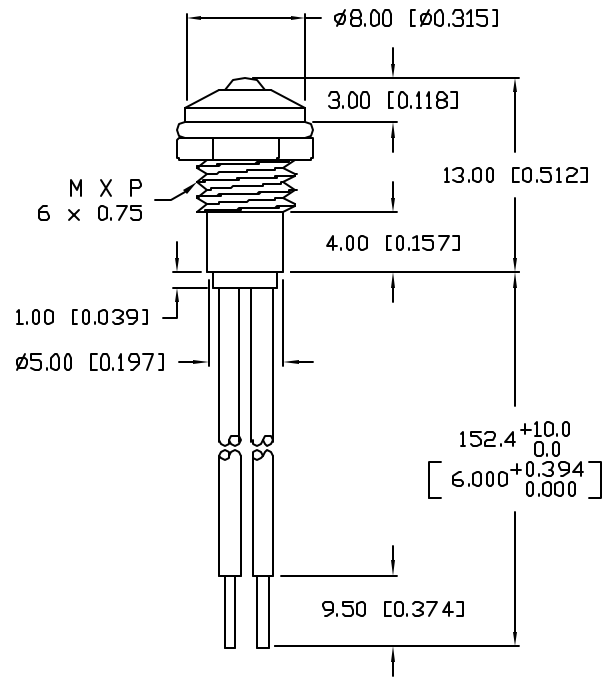
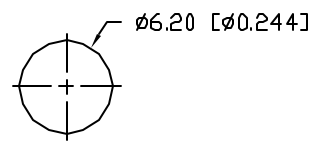

NOTES:

1. SSL-LX3054BID LED, TRIM LEADS TO 5mm.
2. SSI-LXR3612 HOLDER, CHROME FINISH.
3. ANODE LEAD: LXP-WST26RDT0C, 26 AWG. STRANDED, RED INSULATION, CUT TO 157mm LONG, STRIP ENDS 2mm AND 9.5mm.
4. CATHODE LEAD: LXP-WST26BLT0C, 26 AWG. STRANDED, BLACK INSULATION, CUT TO 157mm LONG, STRIP ENDS 2mm AND 9.5mm.
5. SSH-LXH1B12BSG, BUSHING. INSERT AND CRIMP.
6. SOLDER LED LEADS TO WIRE LEADS.

ELECTRO-OPTICAL CHARACTERISTICS $T_A=25^{\circ}\text{C}$

PARAMETER	MIN	TYP	MAX	UNITS	TEST COND
PEAK WAVELENGTH		635 (RED)		nm	
FORWARD VOLTAGE		3.0	14.0	V _f	
BLINKING FREQUENCY:		1.5		Hz	V _f =14.0, I _f =70mA
		2.5		Hz	V _f =3.0, I _f =6mA
AXIAL INTENSITY		6		mcd	V _f =9.0
VIEWING ANGLE		80		2x theta	
EMITTED COLOR:	RED				
EPOXY LENS FINISH:	RED DIFFUSED				

LIMITS OF SAFE OPERATION AT 25°C

PARAMETER	MAX	UNITS
PEAK FORWARD CURRENT	70	mA
FORWARD VOLTAGE	14	V
POWER DISSIPATION	280	mW
DERATE FROM 25°C	-1.2	mW/°C
OPERATING, STORAGE TEMP.	-40 TO +85	°C
SOLDERING TEMP.	+260	°C
2.0mm FROM BODY		3 SEC. MAX

*UNLESS OTHERWISE SPECIFIED TOLERANCES PER DECIMAL PRECISION ARE: X=±1 (±0.039), X.X=±0.5 (±0.020), X.XX=±0.25 (±0.010), X.XXX=±0.127 (±0.005). LEAD SIZE=±0.05 (±0.002), LEAD LENGTH=±0.75 (±0.030). MIN= ^{+0.00}/_{-0.00} DECIMAL PRECISION MAX= ^{+0.00}/_{-0.00} DECIMAL PRECISION

UNCONTROLLED DOCUMENT

REV.	PART NUMBER
A	SSI-LXR3612BID-150
T-3mm (T-1) 635nm RED BLINKING LED PANEL INDICATOR, RED DIFFUSED LENS, WITH 6" WIRE LEADS.	

CONFIDENTIAL INFORMATION
 THE INFORMATION CONTAINED IN THIS DOCUMENT IS THE PROPERTY OF LUMEX INC. EXCEPT AS SPECIFICALLY AUTHORIZED IN WRITING BY LUMEX INC, THE HOLDER OF THIS DOCUMENT SHALL KEEP ALL INFORMATION CONTAINED HEREIN CONFIDENTIAL AND SHALL PROTECT SAME IN WHOLE OR IN PART FROM DISCLOSURE AND DISSEMINATION TO ALL THIRD PARTIES.

RELIABILITY NOTE
 OUR MANY YEARS OF EXPERIENCE DATA ACCUMULATION INDICATE THAT SOLDER HEAT IS A MAJOR CAUSE OF EARLY AND FUTURE FAILURE. PLEASE PAY ATTENTION TO YOUR SOLDERING PROCESS.



290 E. HELEN ROAD
 PALATINE, IL 60067-6976
 PHONE: +1.847.359.2790
 US WEB: www.lumex.com
 TW WEB: www.lumex.com.tw

DRAWN BY:	CHECKED BY:	APPROVED BY:	DATE: 3.10.00
BC			PAGE: 1 OF 1
			SCALE: N/A