

ATLANTIC VERSION TERMINATOR INTERFACE ADAPTER	PART NUMBER	REVISION	DESCRIPTION	FEED TYPE	APPLICATOR STYLE CONVERSION CHART						
					CONVERT TO	PART NUMBERS REQUIRED					
	2150268-2	A	FINE CRIMP HEIGHT ADJUST	PNEUMATIC	SERVO LATCH PLATE	2119951-1	1901697-2	8-2150268-5	-	-	2168400-7 (QUANTITY 2)
	2150268-5	A	FINE CRIMP HEIGHT ADJUST	SERVO LATCH PLATE ⁴	SMART APPLICATOR	2161326-1	-	8-2150268-4	-	-	-
	2150268-6	A	NON-CRIMP HEIGHT ADJUST	SERVO LATCH PLATE ⁴	PNEUMATIC FEED	2119950-1	2119792-1	-	2119641-1	-	2063440-1
	2150268-7	A	FINE CRIMP HEIGHT ADJUST	NONE	-	-	-	-	-	-	-
	7-2150268-7	A	CRIMP TOOLING KIT	-	-	-	-	-	-	-	-

APPLICATOR DATA		
CRIMP	SIZE	TYPE
WIRE	6.02 mm [.237]	D
INSUL	-	-
APPL INSTRUCTIONS 408-10390		

TERMINAL DATA: TE TERMINAL		TE CRIMP SPEC
TERMINAL NAME: RECPT, ULTRA-FAST FLAG, .187 SERIES		
WIRE STRIP LENGTH		INSULATION DIAMETER RANGE
7.51-8.33 mm [.296-.328 IN]		∅ .185 MAX
TERMINAL APPLICATION SPECIFICATION	114-2123	-
TERMINALS APPLIED ⁹		
TE TERMINAL	TE TERMINAL	TE TERMINAL
3-520338-2	6-520338-2	9-520340-2
5-520338-2	3-520340-2	

WIRE SIZE	CRIMP HEIGHT mm [INCH]	CRIMP HEIGHT REFERENCE SETTING	∅ SOLDER
14	1.905+/-0.05 [.075+/- .002]	4.8	.19 in [4.83mm]
16	1.778+/-0.05 [.070+/- .002]	6.0	.19 in [4.83mm]

- ¹ RECOMMENDED SPARE PARTS
- ² GREASE BEARING SURFACES LIGHTLY
- 3. LUBRICATE DAILY PER THE APPLICATOR INSTRUCTION SHEET SUPPLIED WITH THE APPLICATOR.
- ⁴ APPLICATOR SPECIFIC DATA TO BE ENTERED INTO BLANK MEMORY CHIP AT ASSEMBLY. SEE BELOW FOR PART NUMBER:
 PNEUMATIC FEED WITH "SMART APPLICATOR" CONVERSION: 8-2150268-4
 SERVO FEED WITH "FINE CRIMP HEIGHT ADJUST": 8-2150268-5
 SERVO FEED WITH "NON-CRIMP HEIGHT ADJUST": 8-2150268-6
- 5. ADJUSTMENT OF THE STRIPPER MAY BE REQUIRED WHEN MOVING THE APPLICATOR BETWEEN BENCH AND LEADMAKER APPLICATIONS.
- ⁶ GREASE THREADS, GROOVE AND O-RING ON ITEMS 35 & 252.
- ⁷ MAGNET, ITEM 166 MUST BE ORIENTED CORRECTLY IN ORDER TO PROPERLY ACTUATE THE COUNTER.
- ⁸ CRIMP HEIGHT REFERENCE SETTING WAS THE SETTING USED WHEN THE APPLICATOR WAS QUALIFIED AT THE FACTORY. ADJUSTMENT MAY BE NECESSARY WHEN RUNNING APPLICATOR IN THE FIELD.
- ⁹ TERMINAL PITCH NOT COMPATIBLE WITH MECHANICAL FEED.
- ¹⁰ WHEN ASSEMBLING -6 NON-CRIMP HEIGHT ADJUST APPLICATOR USE SHIM PACK 2119957-2 TO ALIGN APPLICATOR'S MAXIMUM WIRE CRIMP HEIGHT AT NORMAL TERMINATOR SHUT HEIGHT
- ¹¹ TO CHECK CRIMP HEIGHT, CRIMP SOLDER (∅.19 IN [4.83mm] 60/40 SOLID CORE) AND MEASURE AT CENTER OF SLUG.

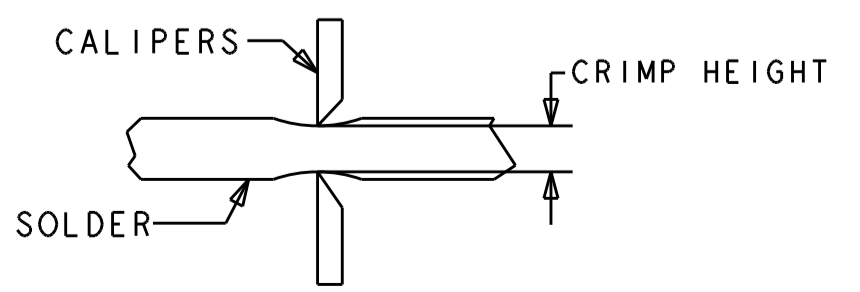

¹² APPLY PART NUMBER 1-23419-5 LOCTITE TO THREADS OF ITEM 62.

SET UP GAUGE	LOC	DIST	REVISIONS			
2119599-2	A	66	REV	DATE	BY	APPD
			A	010CT2012	BW	TE

-	-	1	-	-	2119957-2	APPLICATOR SHIM PACK	260
-	1	-	1	1	8-21084-0	O-RING, .676 ID, .070 DIA. MAT.	252
-	-	-	-	1	2119640-1	PUSH ROD, AIR FEED	250
-	-	-	-	1	2079988-1	BUSHING, LCH5-12, MISUMI	249
-	-	-	-	1	2119641-1	FEED CAM, AIR FEED	248
-	1	-	1	1	2119798-1	DETENT PIN	247
-	1	-	1	1	1-22279-3	SPRING, COMPRESSION	246
-	-	1	-	-	2119759-1	RAM, AMP STYLE, END FEED, NON-ADJUST	245
-	-	2	2	-	2168400-7	SHCS, LOW HEAD, RoHS, M5 X 10	240
-	-	-	-	1	2063440-1	AIR FEED MODULE	238
-	1	1	1	1	2119644-6	RAM WASHER, PRECISION	221
-	-	1	1	-	2119740-2	TAG, IDENTIFICATION	213
-	1	1	1	1	467281-1	RETAINER, SHEAR, FLOATING	207
-	1	1	1	1	2161936-1	HOLDER, SHEAR, FLOATING	206
-	1	1	1	1	467500-1	SHEAR, FLOATING	205
-	-	REFREF	-	-	1901697-2	FEED FINGER ASSEMBLY, EF	183
-	-	-	-	2	21045-3	RING, RETAIN, EXTERN, 3/16 CRESCENT	172
-	1	1	1	1	994969-1	MAGNET, RARE EARTH HIGH ENERGY	166
-	REFREF	REFREF	REFREF	REFREF	994970-2	COUNTER, MAGNETIC	164
-	-	-	-	1	240638-1	SPRING, FEED FINGER	163
-	1	1	1	1	2161937-2	STABILIZER	154
-	-	-	-	1	3-23627-7	PIN, RETAIN, GRVD, 3/16 X .854	137
-	-	REFREF	-	-	SEE NOTE 4	MEMORY CHIP, PROGRAMMED	135
-	-	1	1	-	1633743-1	SERVO FEED LATCH ASM	133
-	1	1	1	1	2119956-2	DOCUMENTATION PACKAGE	71
-	1	1	1	1	3-18032-3	SCR, SET, FLT POINT M3 X 20.0	70
-	1	1	1	1	2-18032-2	SCR, SET, FLT POINT M3 X 10.0	69
-	1	-	-	1	2119740-1	TAG, IDENTIFICATION	67
-	2	2	2	2	2168078-1	SCREW, DRIVE, RH, RoHS	66
-	1	-	1	1	2119793-1	LIMITER, ADJUSTMENT BOLT	63
-	3	-	3	3	992763-5	SCR, SET, SOC, CONE POINT, M3 x 4.0	62
-	3	3	3	3	2079383-4	SCR, BHSC, RoHS (M4 X 8)	60
-	4	4	4	4	2168400-1	SHCS, LOW HEAD, RoHS, M4 X 12	57
-	2	2	2	2	2168083-2	SCR, SKT HD CAP, RoHS, M4 X 8.0	56
-	2	2	2	2	5018030-1	NUT, HEX, REG, RoHS, M3	54
-	2	2	2	2	986965-8	NUT, LOCK, HEX, TORQUE (M4)	53
-	-	-	-	1	2161952-1	PAWL, EF, AIR	51
-	-	-	-	1	18023-9	SCR, SKT HD CAP M4 X 6.0	49
-	1	1	1	1	1-2119655-5	APPLICATOR BASIC ASSEMBLY, EF	46
-	1	-	1	1	2119369-1	RAM, AMP STYLE, END FEED	44
-	1	1	1	1	2079383-7	SCR, BHSC, RoHS (M8 X 25)	41
-	1	-	1	1	2119645-1	DISC, NUMBERED FA WIRE ADJUSTMENT	40
-	1	-	1	1	2119957-1	APPLICATOR SHIM PACK	39
-	1	1	1	1	2119644-7	RAM WASHER, PRECISION	38
-	1	1	1	1	2119085-1	FA HEAD, ATLANTIC STYLE	37
-	2	2	2	2	5-22278-1	SPRING, COMPRESSION	36
-	1	-	1	1	2119092-1	BOLT, ADJUSTMENT	35
-	8	8	8	8	1-18028-2	WASHER, FLAT, REG M4	33
-	2	2	2	2	2079383-4	SCR, BHSC, RoHS (M4 X 8)	31
-	2	2	2	2	1-2168083-0	SCR, SKT HD CAP, RoHS, M4 X 10	29
-	1	1	1	1	690455-3	STRIPPER, FRONT CASTING	27
-	2	2	2	2	1-2168083-6	SCR, SKT HD CAP, RoHS, M4 X 35	25
-	1	1	1	1	2161941-2	PLATE, GUIDE, STRIP	24
-	2	2	2	2	22281-9	SPRING, COMPRESSION	22
-	1	1	1	1	2161948-1	DRAG	20
-	1	1	1	1	683736-1	GUIDE, STRIP, REAR	19
-	1	1	1	1	683737-1	FRONT STRIP GUIDE	18
-	4	4	4	4	1-2079383-1	SCR, BHSC, RoHS (M6 X 12)	17
-	1	1	1	1	4-22280-7	SPRING, COMPRESSION	13
-	1	1	1	1	2161935-3	ANVIL, RIGHT HAND	8
-	1	1	1	1	2161957-1	DEPRESSOR, SHEAR	5
-	1	1	1	1	238009-1	BLOCK, FL CRIMPER SPACER	4
-	1	1	1	1	2161331-1	SPACER, WIRE FUNNEL DEPRESSOR	2
-	1	1	1	1	467342-4	CRIMPER, RIGHT HAND	1

***WARNING**
 ON INSTALLATION, SET WIRE DISC, ITEM 40 TO LARGEST WIRE SIZE SETTING. USE OF SETTINGS BELOW MINIMUM REQUIRED CRIMP HEIGHT SETTING WILL CAUSE DAMAGE TO CRIMP TOOLING.

ATLANTIC VERSION
 Shown on sheets 1 of 4 & 2 of 4
 (Pacific version shown on sheets 3 of 4 & 4 of 4)

DIMENSIONS:		TOLERANCES UNLESS OTHERWISE SPECIFIED:		DWG		REV		DATE		BY		APPD	
mm		0 PLC ±.5 1 PLC ±0.5 2 PLC ±0.13 3 PLC ±0.013 4 PLC ±0.0013 ANGLES ±.01		B. WEAVER		T. ELBIN		19JUN2012		19JUN2012		T. ELBIN	
MATERIAL:		FINISH:		NAME		PRODUCT SPEC		APPLICATION SPEC		SIZE		CAGE CODE DRAWING NO	
-		-		Ocean End Feed Applicator		-		-		A1 00779		C=2150268	
-		-		RESTRICTED TO		WEIGHT		SCALE		SHEET		REV	
-		-		-		-		1:1		1 OF 4		A	

LOC	DIST	REV	DATE	BY	APPV
A	66				
		DESCRIPTION	DATE	BY	APPV
		SEE SHEET 1			

FEED TYPE

PNEUMATIC

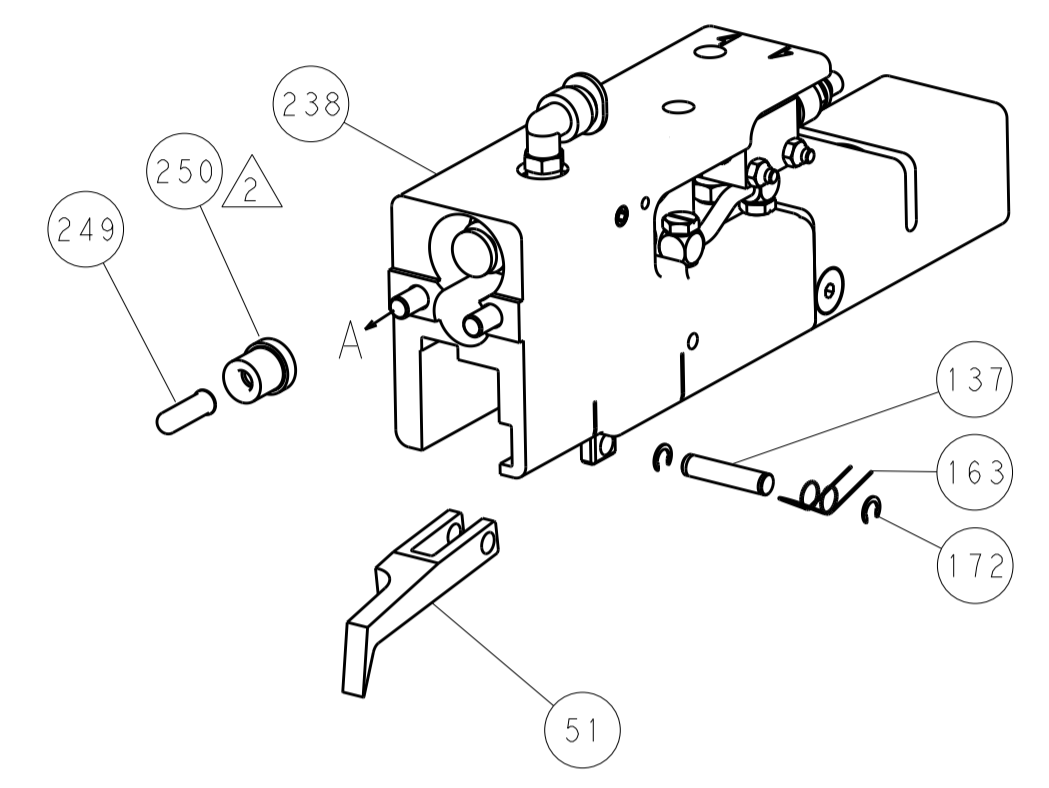

SERVO LATCH PLATE

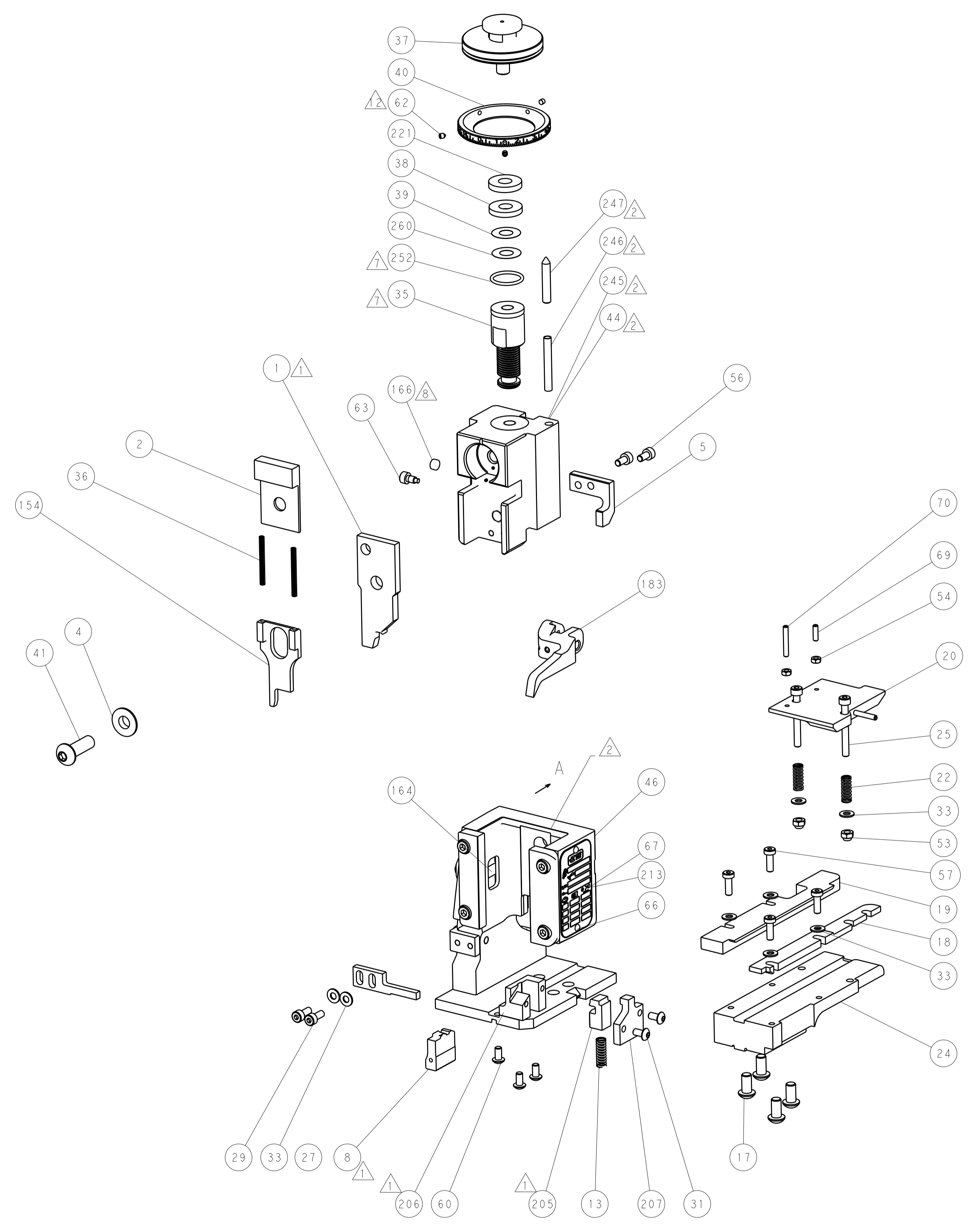
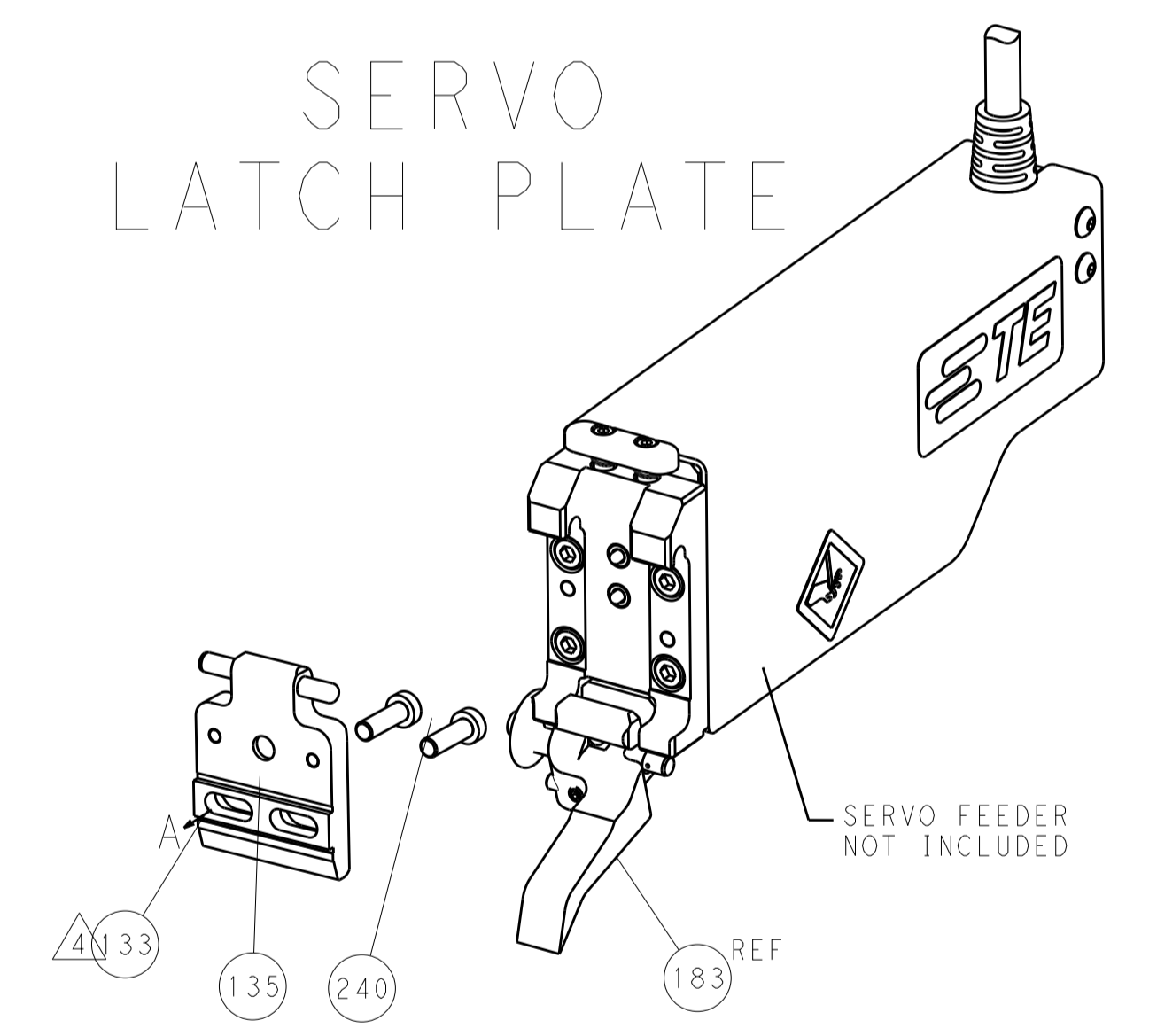

CAM POSITION

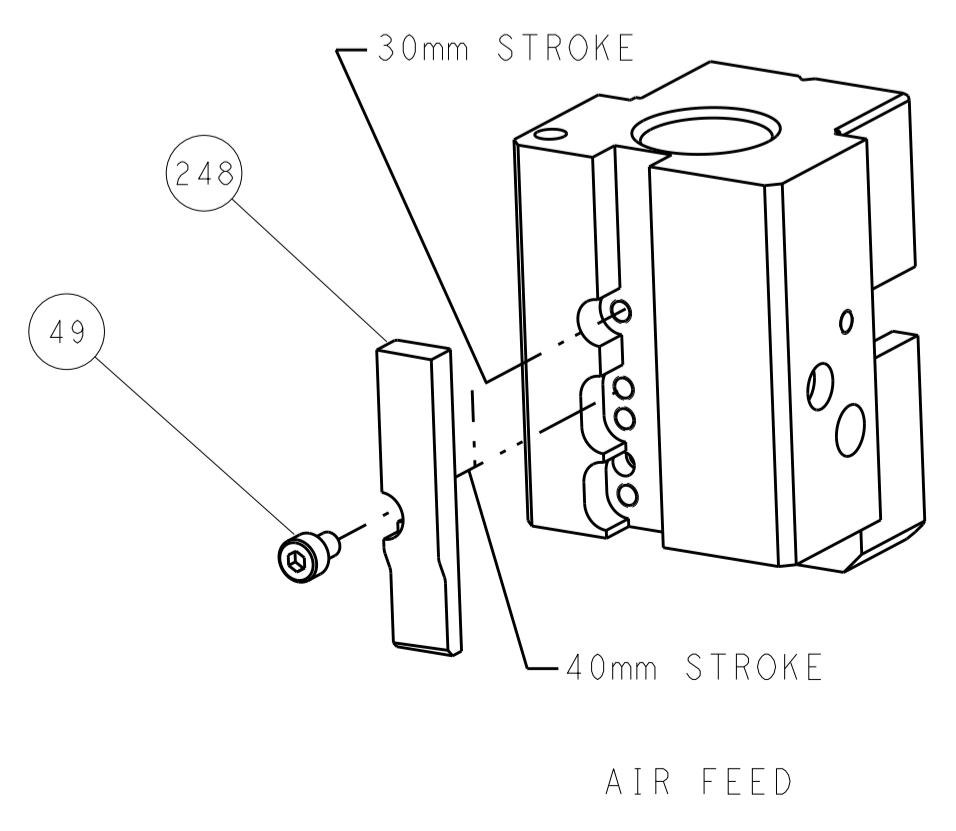

ATLANTIC VERSION
 Shown on sheets 1 of 4 & 2 of 4
 (Pacific version shown on sheets 3 of 4 & 4 of 4)

DIMENSIONS:		TOLERANCES UNLESS OTHERWISE SPECIFIED:		DWG: B. WEAVER 19JUN2012		TE Connectivity	
mm		0 PLC ±0.5		CHK: T. ELBIN 19JUN2012		Harrisburg, PA 17105-3608	
Ø		1 PLC ±0.5		APPV: T. ELBIN 19JUN2012		NAME: Ocean End Feed Applicator	
H		2 PLC ±0.13		PRODUCT SPEC		SIZE: CAGE CODE: DRAWING NO: RESTRICTED TO	
D		3 PLC ±0.013		APPLICATION SPEC		A11 00779 ©=2150268	
R		4 PLC ±0.0001		WEIGHT		SCALE: 1:1 SHEET 2 OF 4 REV A	
ANGLES		FINISH		Customer Accessible Production Drawing			

PACIFIC VERSION TERMINATOR INTERFACE ADAPTER	PART NUMBER	REVISION	DESCRIPTION	FEED TYPE	APPLICATOR STYLE CONVERSION CHART						
					CONVERT TO	PART NUMBERS REQUIRED					
	2-2150268-2	A	FINE CRIMP HEIGHT ADJUST	PNEUMATIC	SERVO LATCH PLATE	2119951-1	1901697-2	8-2150268-5	-	-	2168400-7 (QUANTITY 2)
	2-2150268-5	A	FINE CRIMP HEIGHT ADJUST	SERVO LATCH PLATE ⁴	SMART APPLICATOR	2161326-1	-	8-2150268-4	-	-	-
	2-2150268-7	A	FINE CRIMP HEIGHT ADJUST	NONE	PNEUMATIC FEED	2119950-1	2119792-1	-	2119641-2	-	2063440-1
	7-2150268-7	A	CRIMP TOOLING KIT	-	-	-	-	-	-	-	-

APPLICATOR DATA		
CRIMP WIRE	SIZE	TYPE
INSUL	6.02 mm [.237]	D
APPL INSTRUCTIONS		
408-10390		

TERMINAL DATA: TE TERMINAL		TE CRIMP SPEC
TERMINAL NAME: RECPT, ULTRA-FAST FLAG, .187 SERIES		
WIRE STRIP LENGTH		INSULATION DIAMETER RANGE
7.51-8.33 mm [.296- .328 IN]		∅ .185 MAX
TERMINAL APPLICATION SPECIFICATION	114-2123	
TERMINALS APPLIED ⁹		
TE TERMINAL	TE TERMINAL	TE TERMINAL
3-520338-2	6-520338-2	9-520340-2
5-520338-2	3-520340-2	

WIRE SIZE	CRIMP HEIGHT mm [INCH]	CRIMP HEIGHT REFERENCE SETTING ⁸	∅ SOLDER ¹⁰
14	1.905+/-0.05 [.075+/- .002]	4.8	.19 in [4.83mm]
16	1.778+/-0.05 [.070+/- .002]	6.0	.19 in [4.83mm]

- RECOMMENDED SPARE PARTS
- GREASE BEARING SURFACES LIGHTLY
- 3. LUBRICATE DAILY PER THE APPLICATOR INSTRUCTION SHEET SUPPLIED WITH THE APPLICATOR.
- APPLICATOR SPECIFIC DATA TO BE ENTERED INTO BLANK MEMORY CHIP AT ASSEMBLY. SEE BELOW FOR PART NUMBER:
 PNEUMATIC FEED WITH "SMART APPLICATOR" CONVERSION: 8-2150268-4
 SERVO FEED WITH "FINE CRIMP HEIGHT ADJUST": 8-2150268-5
- 5. ADJUSTMENT OF THE STRIPPER MAY BE REQUIRED WHEN MOVING THE APPLICATOR BETWEEN BENCH AND LEADMAKER APPLICATIONS.
- GREASE THREADS, GROOVE AND O-RING ON ITEMS 139 & 153.
- MAGNET, ITEM 166 MUST BE ORIENTED CORRECTLY IN ORDER TO PROPERLY ACTUATE THE COUNTER.
- CRIMP HEIGHT REFERENCE SETTING WAS THE SETTING USED WHEN THE APPLICATOR WAS QUALIFIED AT THE FACTORY. ADJUSTMENT MAY BE NECESSARY WHEN RUNNING APPLICATOR IN THE FIELD.
- TERMINAL PITCH NOT COMPATIBLE WITH MECHANICAL FEED.
- TO CHECK CRIMP HEIGHT, CRIMP SOLDER (∅.19 IN [4.83mm] 60/40 SOLID CORE) AND MEASURE AT CENTER OF SLUG.

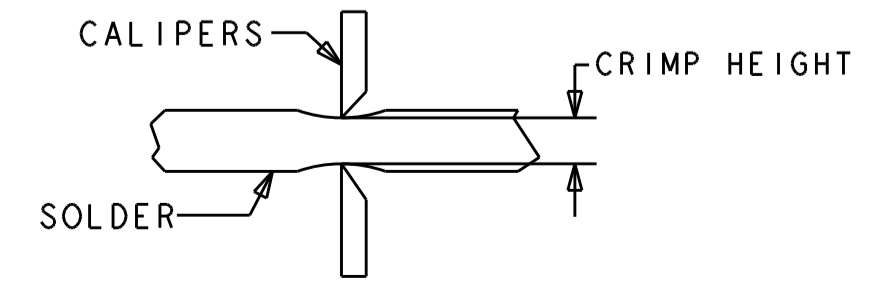

APPLY PART NUMBER 1-23419-5 LOCTITE TO THREADS OF ITEM 62

***WARNING**
 ON INSTALLATION, SET WIRE DISC, ITEM 40 TO LARGEST WIRE SIZE SETTING. USE OF SETTINGS BELOW MINIMUM REQUIRED CRIMP HEIGHT SETTING WILL CAUSE DAMAGE TO CRIMP TOOLING.

PACIFIC VERSION
 Shown on sheets 3 of 4 & 4 of 4
 (Atlantic version shown on sheets 1 of 4 & 2 of 4)

SET UP GAUGE	LOC	DIST	REVISIONS			
2119599-2	A	66	REV	DATE	BY	APPD
			-	SEE SHEET 1	-	-

-	1	1	1	2119782-1	FINE ADJUST HEAD ASM, PACIFIC STYLE	251
-	-	-	1	2119640-1	PUSH ROD, AIR FEED	250
-	-	-	1	2079988-1	BUSHING, LCH5-12, MISUMI	249
-	1	1	1	1-22279-3	SPRING, COMPRESSION	246
-	-	2	-	2168400-7	SHCS, LOW HEAD, RoHS, M5 X 10	240
-	-	-	1	2063440-1	AIR FEED MODULE	238
-	1	1	1	2119644-6	RAM WASHER, PRECISION	221
-	-	1	-	2119740-2	TAG, IDENTIFICATION	213
-	1	1	1	467281-1	RETAINER, SHEAR, FLOATING	207
-	1	1	1	2161936-1	HOLDER, SHEAR, FLOATING	206
-	1	1	1	467500-1	SHEAR, FLOATING	205
-	4	4	4	2079383-9	SCR, BHSC, RoHS (M6 X 20)	186
-	-	REF	-	1901697-2	FEED FINGER ASSEMBLY, EF	183
-	-	-	2	21045-3	RING, RETAIN, EXTERN, 3/16 CRESCENT	172
-	1	1	1	994969-1	MAGNET, RARE EARTH HIGH ENERGY	166
-	REF	REF	REF	994970-2	COUNTER, MAGNETIC	164
-	-	-	1	240638-1	SPRING, FEED FINGER	163
-	1	1	1	2161937-2	STABILIZER	154
-	1	1	1	8-21084-1	O-RING, .801 ID, .070 DIA. MAT.	153
-	-	-	1	2119641-2	FEED CAM, AIR FEED	152
-	1	1	1	2119798-2	DETENT PIN	145
-	3	3	3	2079383-8	SCR, BHSC, RoHS (M4 X 16)	144
-	1	1	1	1-2119655-6	APPLICATOR BASIC ASSEMBLY, EF	141
-	1	1	1	2119651-1	RAM, ASIAN STYLE, END FEED	140
-	1	1	1	2119092-2	BOLT, ADJUSTMENT	139
-	-	-	1	3-23627-7	PIN, RETAIN, GRVD, 3/16 X .854	137
-	-	REF	-	SEE NOTE 4	MEMORY CHIP, PROGRAMMED	135
-	-	1	-	1633743-1	SERVO FEED LATCH ASM	133
-	1	1	1	2119956-2	DOCUMENTATION PACKAGE	71
-	1	1	1	3-18032-3	SCR, SET, FLT POINT M3 X 20.0	70
-	1	1	1	2-18032-2	SCR, SET, FLT POINT M3 X 10.0	69
-	1	-	1	2119740-1	TAG, IDENTIFICATION	67
-	2	2	2	2168078-1	SCREW, DRIVE, RH, RoHS	66
-	1	1	1	2119793-1	LIMITER, ADJUSTMENT BOLT	63
-	3	3	3	992763-5	SCR, SET, SOC, CONE POINT, M3 X 4.0	62
-	4	4	4	2168400-1	SHCS, LOW HEAD, RoHS, M4 X 12	57
-	2	2	2	2168083-2	SCR, SKT HD CAP, RoHS, M4 X 8.0	56
-	2	2	2	5018030-1	NUT, HEX, REG, RoHS, M3	54
-	2	2	2	986965-8	NUT, LOCK, HEX, TORQUE (M4)	53
-	-	-	1	2161952-1	PAWL, EF, AIR	51
-	-	-	1	18023-9	SCR, SKT HD CAP M4 X 6.0	49
-	1	1	1	2079383-7	SCR, BHSC, RoHS (M8 X 25)	41
-	1	1	1	2119645-1	DISC, NUMBERED FA WIRE ADJUSTMENT	40
-	1	1	1	2119957-1	APPLICATOR SHIM PACK	39
-	1	1	1	2119644-7	RAM WASHER, PRECISION	38
-	2	2	2	5-22278-1	SPRING, COMPRESSION	36
-	8	8	8	1-18028-2	WASHER, FLAT, REG M4	33
-	2	2	2	2079383-4	SCR, BHSC, RoHS (M4 X 8)	31
-	2	2	2	1-2168083-0	SCR, SKT HD CAP, RoHS, M4 X 10	29
-	1	1	1	690455-3	STRIPPER, FRONT CASTING	27
-	2	2	2	1-2168083-6	SCR, SKT HD CAP, RoHS, M4 X 35	25
-	1	1	1	2161941-2	PLATE, GUIDE, STRIP	24
-	2	2	2	22281-9	SPRING, COMPRESSION	22
-	1	1	1	2161948-1	DRAG	20
-	1	1	1	683736-1	GUIDE, STRIP, REAR	19
-	1	1	1	683737-1	FRONT STRIP GUIDE	18
-	1	1	1	4-22280-7	SPRING, COMPRESSION	13
	1	1	1	2161935-3	ANVIL, RIGHT HAND	8
-	1	1	1	2161957-1	DEPRESSOR, SHEAR	5
-	1	1	1	238009-1	BLOCK, FL CRIMPER SPACER	4
-	1	1	1	2161331-1	SPACER, WIRE FUNNEL DEPRESSOR	2
	1	1	1	467342-4	CRIMPER, RIGHT HAND	1

DIMENSIONS:		TOLERANCES UNLESS OTHERWISE SPECIFIED:		MATERIAL:	
mm	0 PLC ±.5	1 PLC ±0.5	2 PLC ±0.13	3 PLC ±0.013	4 PLC ±0.001
	ANGLES ±.0001				
	FINISH				

CHK	DATE	NAME
B. WEAVER	19JUN2012	
T. ELBIN	19JUN2012	
T. ELBIN	19JUN2012	

SIZE	CAGE CODE	DRAWING NO	RESTRICTED TO
A1	00779	2150268	-

Customer Accessible Production Drawing SCALE 1:1 SHEET 3 OF 4 REV A

LOC	DIST	REV	DATE	BY	APPV
A	66				

FEED TYPE

PNEUMATIC

SERVO LATCH PLATE

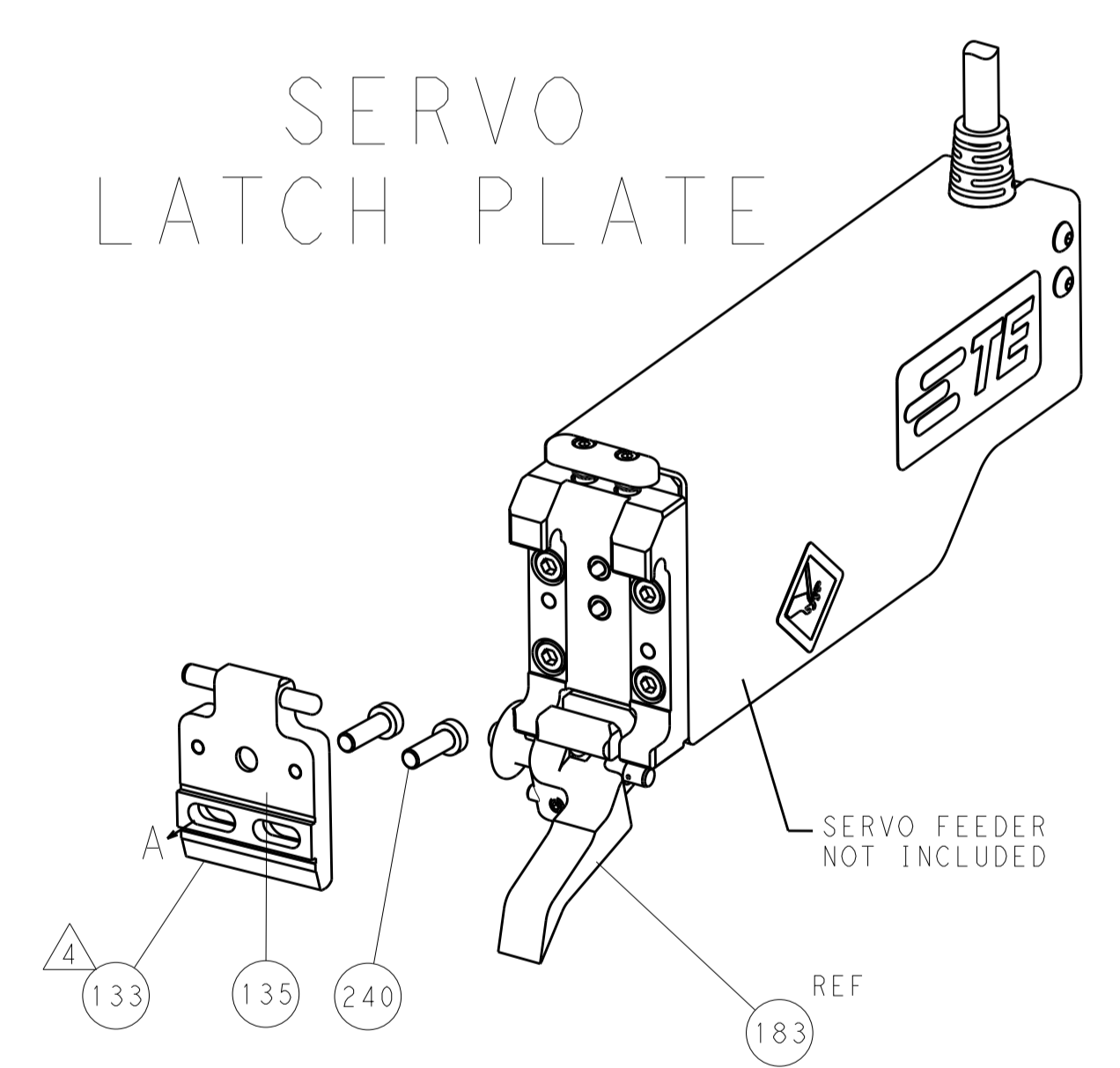
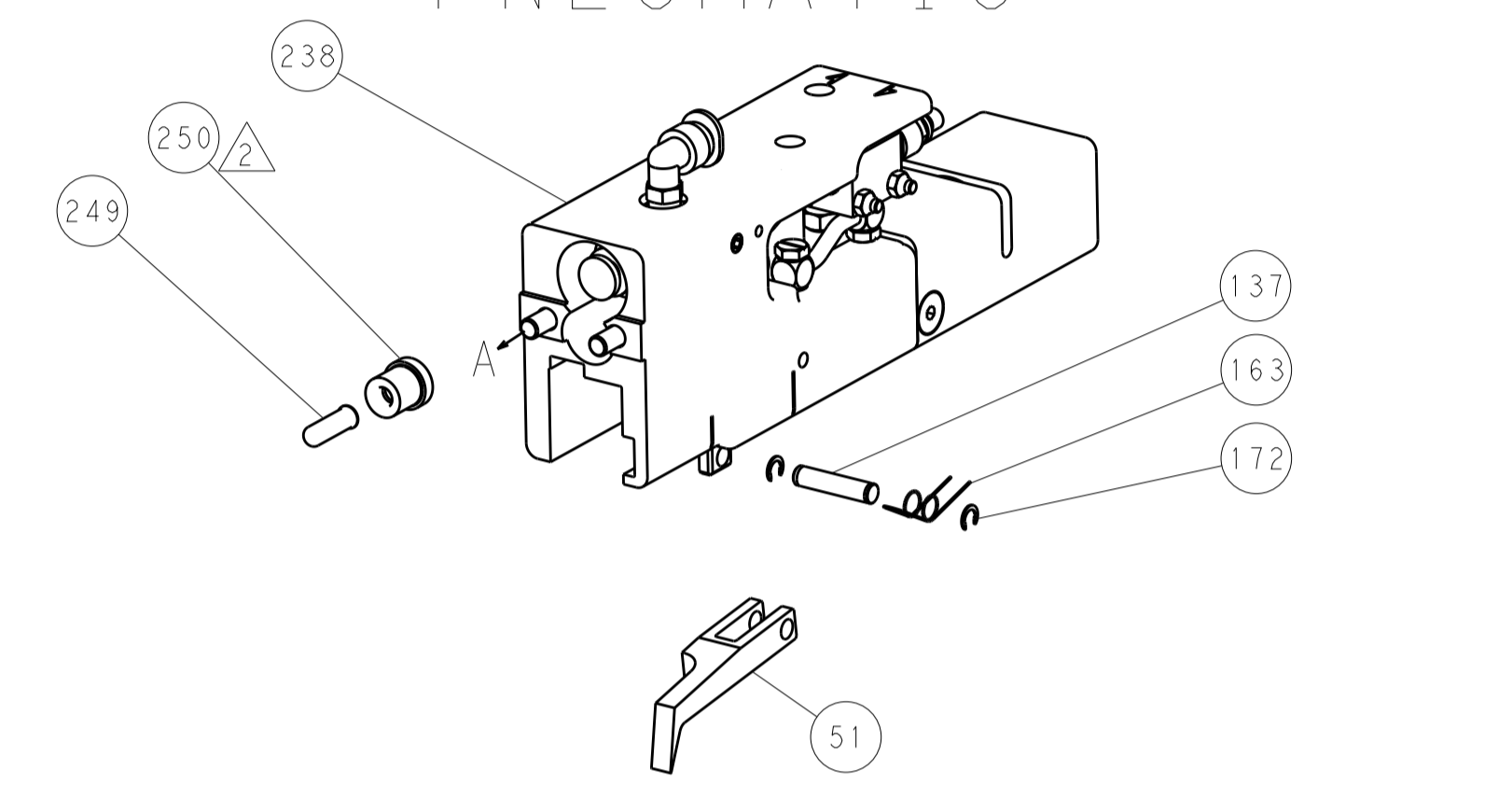
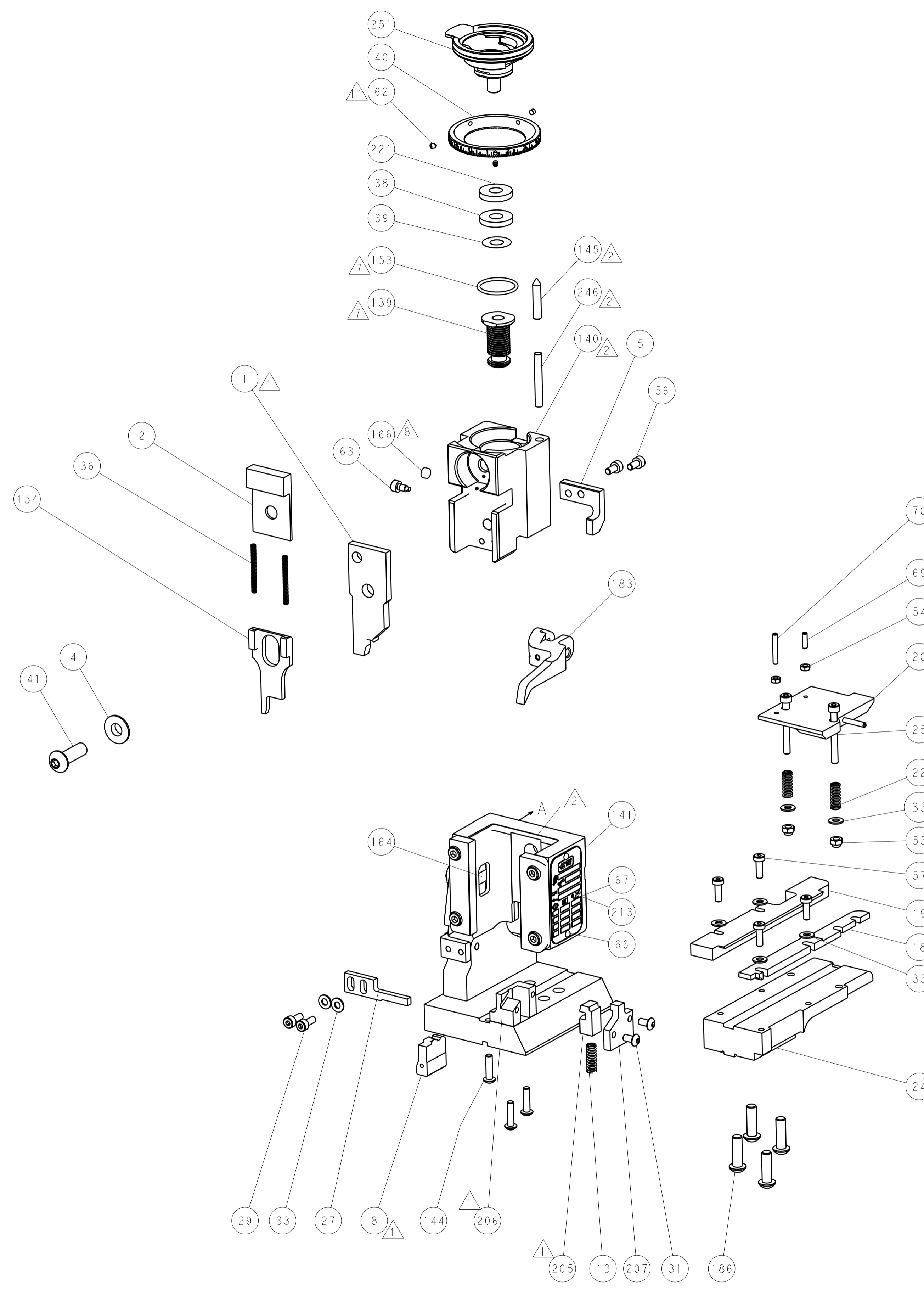

CAM POSITION

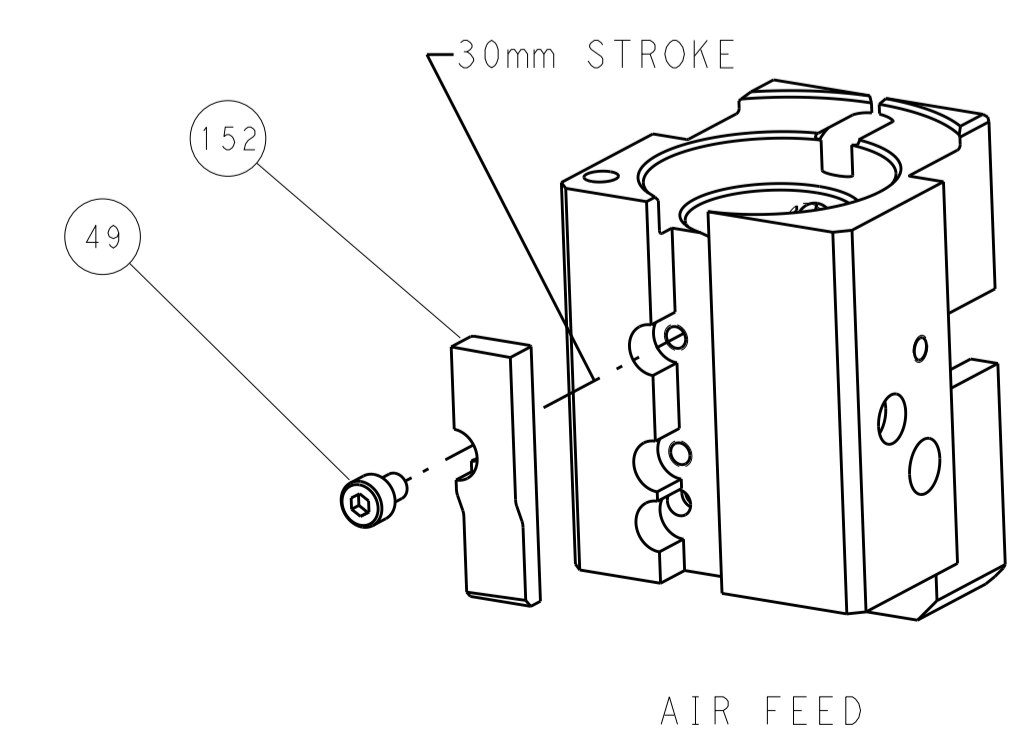

PACIFIC VERSION
 Shown on sheets 3 of 4 & 4 of 4
 (Atlantic version shown on sheets 1 of 4 & 2 of 4)

DIMENSIONS:		TOLERANCES UNLESS OTHERWISE SPECIFIED:		MATERIAL:		FINISH:	
mm	0 PLC ±0.5	1 PLC ±0.5	2 PLC ±0.13	3 PLC ±0.013	4 PLC ±0.001	ANGLES ±0.001	

OWN	B. WEAVER	19JUN2012	NAME	Ocean End Feed Applier	
CHK	T. ELBIN	19JUN2012	SIZE	CAGE CODE	DRAWING NO
APPV	T. ELBIN	19JUN2012	SCALE	1:1	SHEET 4 OF 4
PRODUCT SPEC			WEIGHT	A11 00779	REV A
APPLICATION SPEC			RESTRICTED TO		
Customer Accessible Production Drawing			SCALE 1:1 SHEET 4 OF 4 REV A		