

**SAW Filter 408.0MHz**  
**Part No: MP05392**

**Model: TA1542A**  
**Rev No: 1**

**A. MAXIMUM RATING:**

Electrostatic Sensitive Device (ESD)

1. Input Power Level: 10dBm
2. DC Voltage: 3V
3. Operating Temperature: +15°C to +35°C
4. Storage Temperature: -40°C to +85°C

**B. ELECTRICAL CHARACTERISTICS:**

Item	Unit	Min.	Typ.	Max.
Center frequency Fc	MHz	-	408	-
Insertion Loss (405.5 ~ 410.5MHz) IL	dB	-	2.4	3.6
Amplitude Ripple (405.5 ~ 410.5MHz)	dB	-	0.8	2.1
VSWR (405.5 ~ 410.5MHz)	-	-	1.4	2.1
Attenuation (Reference level from 0dB)				
10 ~ 371MHz	dB	40	62	-
371 ~ 386MHz	dB	31	66	-
386 ~ 397.5MHz	dB	10	48	-
434 ~ 461MHz	dB	37	55	-
461 ~ 542MHz	dB	40	64	-
Temperature coefficient of frequency	ppm/k	-	-36	-

**C. MEASUREMENT CIRCUIT:**

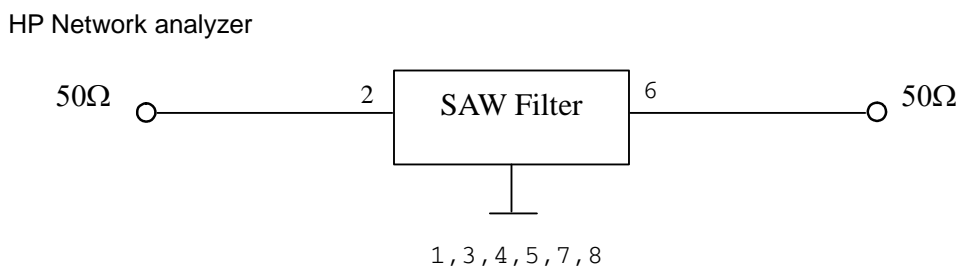

**SAW Filter 408.0MHz**  
**Part No: MP05392**

**Model: TA1542A**  
**Rev No: 1**

**D. OUTLINE DRAWING:**

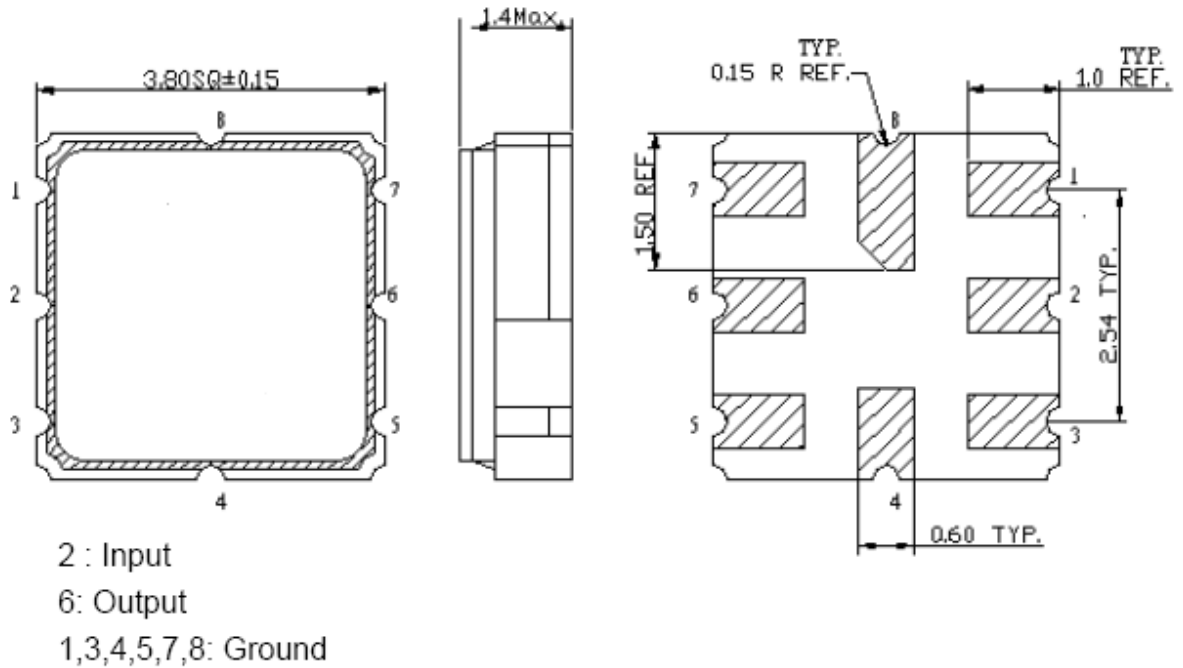

**E. PCB FOOTPRINT:**

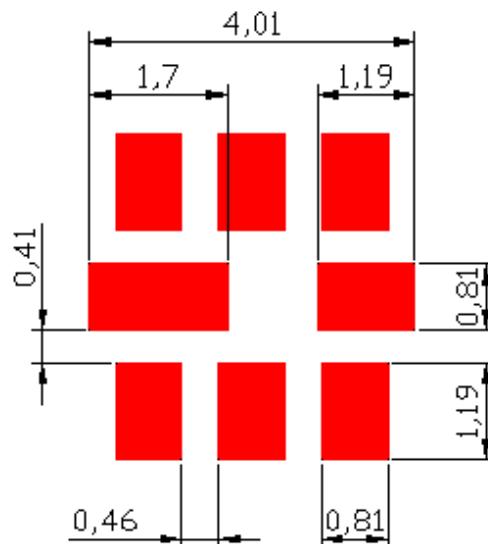

**SAW Filter 408.0MHz**  
**Part No: MP05392**

**Model: TA1542A**  
**Rev No: 1**

**F. FREQUENCY CHARACTERISTICS:**

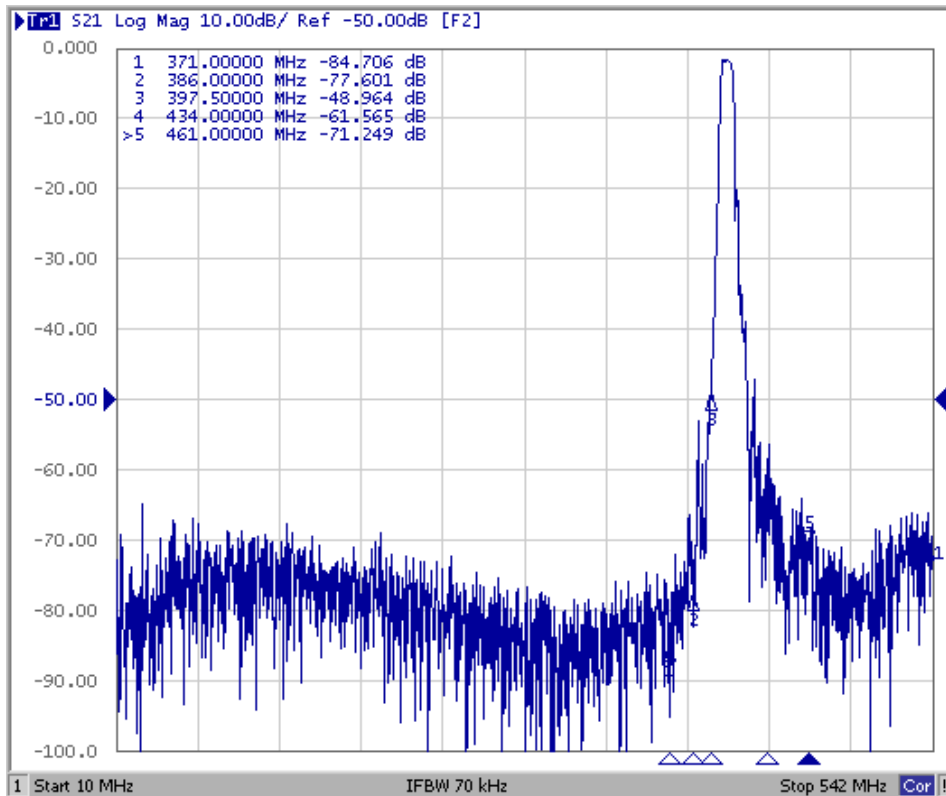
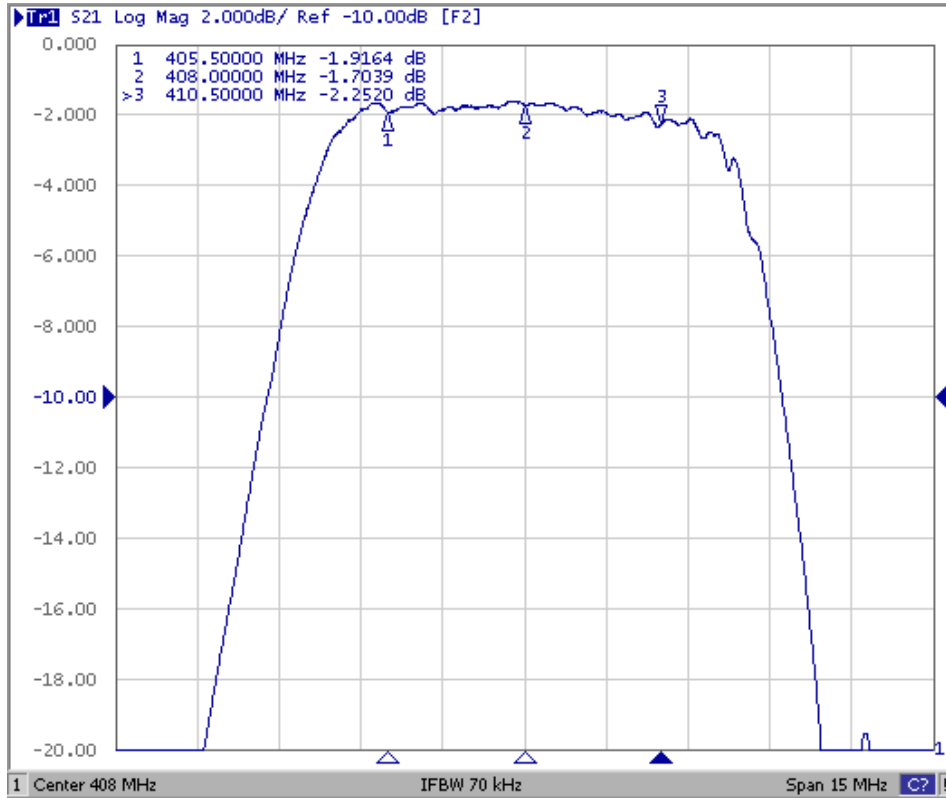

**SAW Filter 408.0MHz**  
**Part No: MP05392**

**Model: TA1542A**  
**Rev No: 1**

Reflection Functions

S11

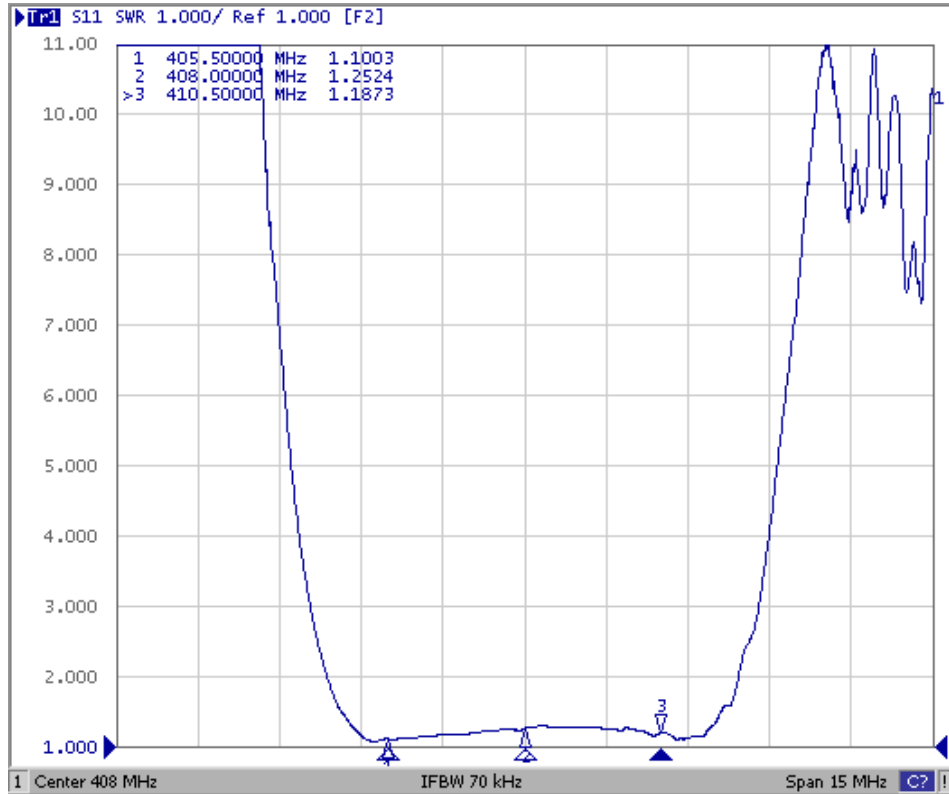

S22

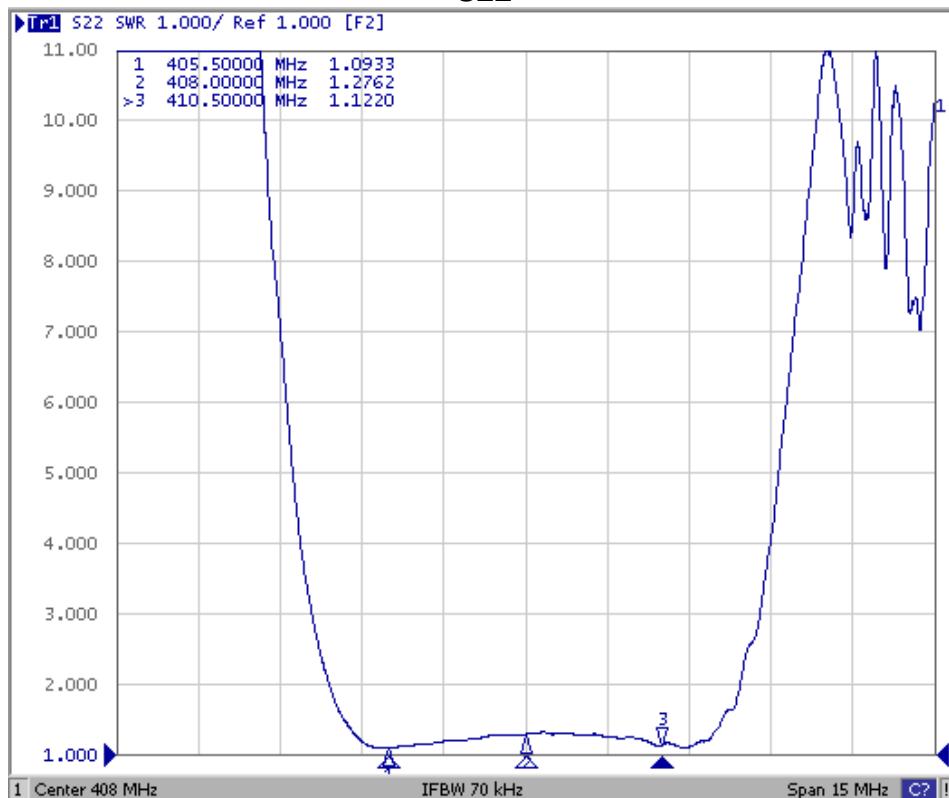

**SAW Filter 408.0MHz**  
**Part No: MP05392**

**Model: TA1542A**  
**Rev No: 1**

**G. PACKING:**

1. Reel Dimension (Please refer to FR-75D10 for packing quantity)

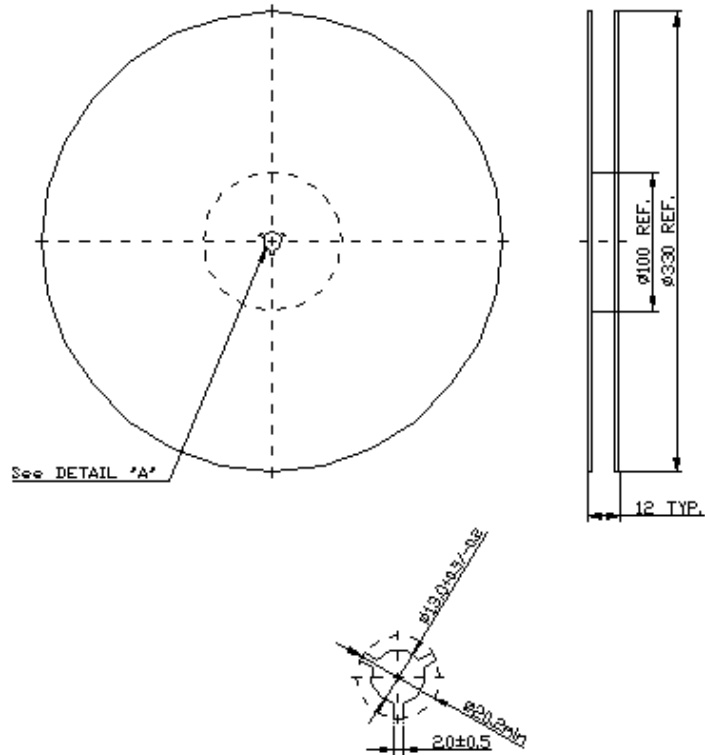

2. Tape Dimension

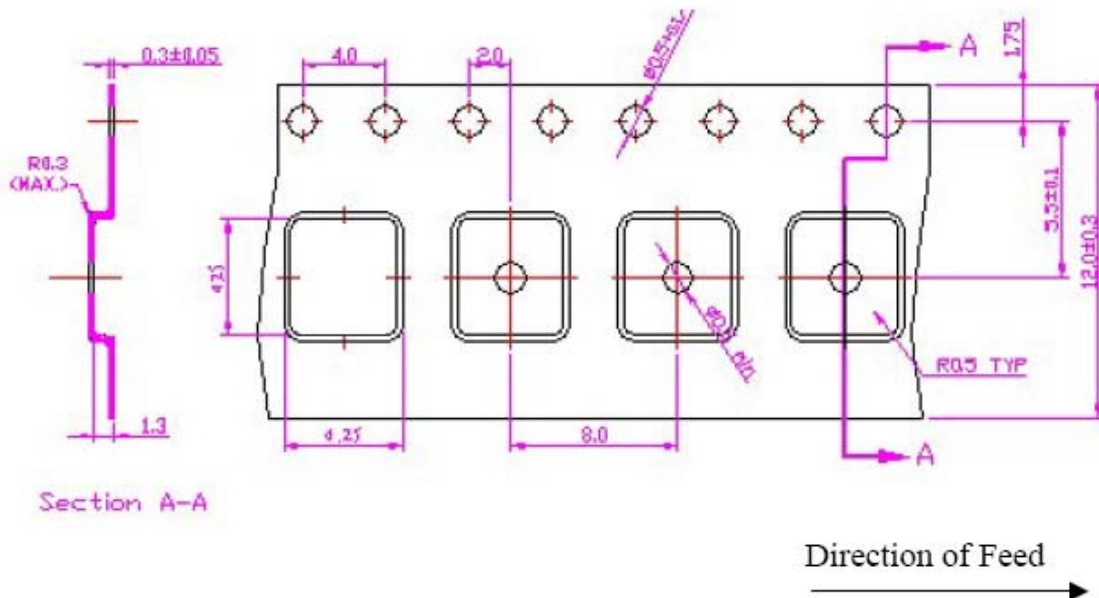

**SAW Filter 408.0MHz**  
**Part No: MP05392**

**Model: TA1542A**  
**Rev No: 1**

**H. RECOMMENDED REFLOW PROFILE:**

