



GT Sensors™

Precision Gear Tooth and Encoder Sensors

NVE's GT Sensor™ products are based on a Low Hysteresis GMR sensor material and are designed for use in industrial speed applications where magnetic detection of gear teeth and magnetic encoder wheels is required.

GT Sensors with both analog and digital outputs are available. The analog parts feature the large signal and robust characteristics which NVE's GMR materials are known for (NVE's GMR sensors are not damaged by extremely large magnetic fields). The sensor elements themselves are designed to provide usable output with even the smallest gear teeth. Single and double output versions are available; the second output is phase shifted with respect to the first, to provide quadrature for determining direction.



The digital sensors take advantage of the high performance characteristics of GMR sensors to provide a 50% duty cycle output with a wide tolerance in airgap and temperature variations.

GT Sensors are available in low-profile MSOP8, TDFN SO8, and TDFN6 packages, in order to fit into the tightest possible spaces. An evaluation kit is available, containing a selection of sensors, magnets, and PCBs, so that the user can test the parts in their application

ABL Sensors

Single/Double Bridge Gear Tooth And Encoder Sensors

Features:

- Large Airgap
- Direct Analog Output
- DC (Zero Speed) Operation
- Sine / Cosine Outputs
- Precise Spacing and Phase Shifting Between Sensor Elements
- Excellent Temperature and Voltage Performance
- Small, Low-Profile Surface Mount Packages

Applications:

- Linear and Angular Speed Sensing
- Linear and Angular Position Sensing
- Direction Detection

Description:

The ABL-Series GT Sensors are differential sensor elements that provide an analog sinusoidal output signal when used with a bias magnet and gear tooth or a magnetic encoder. These chips use NVE's proprietary GMR sensor elements featuring an extremely large output signal from the raw sensor element, which is stable over the rated temperature and voltage range. As a result, ABL-Series GT Sensors feature excellent airgap performance and an extremely stable operating envelope as well as the robust reliability characteristics that NVE sensors are known for.

Three different standard spacings are available for use with fine and coarse pitch encoders and gear teeth. Both single bridge and double bridge configurations are also available. Double bridges are used to generate sine/cosine outputs. In addition to the standard spacings, NVE can provide custom spacings and multiple sensor elements tailored to the individual customer's application for a nominal design and tooling charge. Contact NVE for further details.

For digital output applications, these sensors can be used with NVE's DD001-12 signal processing IC which converts their output into a 50% duty cycle modulated current signal. This IC allows placement of the ABL sensor in a very small housing with wires running from the sensor to the signal processing IC in a remote location. Thus ABL-Series sensors can be used in M8 and smaller housings.

Specifications:

Parameter	Min	Typ	Max	Unit
Single Bridge Resistance at 25°C	4K	5K	7K	Ohms
Input Voltage	<1 ¹		30 ¹	Volts
Operating Temperature Range	-50		+150	°C
Offset Voltage	-4		+4	mV/V
Linear Range	±5		±100	Oe
Linearity of Output	98			% ²
Hysteresis			2	% ²
Saturation of GMR Sensor Elements	-180		+180	Oe ³
Single Resistor Sensitivity		.04		%ΔR/Oe ⁴
Max Output		80		mV/V
Temperature Coefficient of Resistance		+0.11		%/°C
ESD		400		V ⁵
Storage Temperature Range	-65		+170	°C

Notes:

1. ABL-Series sensors have a purely ratiometric output. They will operate with input voltages of 0.1 V or lower. The output signal will scale proportionally with the input voltage. Maximum voltage will be limited by the power dissipation allowable in the package and user installation. See the package section for more details.
2. Linearity and Hysteresis measured across linear operating range, unipolar operation.
3. Application of a magnetic field in excess of this value will saturate the GMR sensor elements and no further output will be obtained. No damage occurs to the sensor elements when saturated. *NVE GMR sensors will not be damaged by any large magnetic field.*
4. Percent change in resistance with application of 1 Oersted of magnetic field; corresponds to an 8% change in resistance with 200 Oersteds of applied magnetic field (1 Oersted = 1 Gauss in air, or 0.1 milliTesla).
5. Pin-to-pin voltage, Human Body Model for ESD.

IC Drawings:

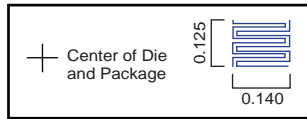

ABL004

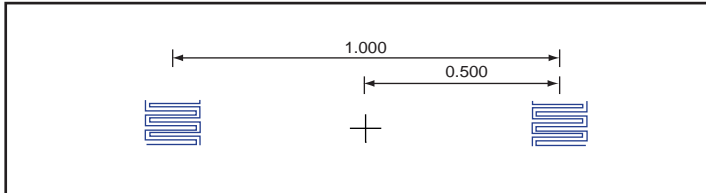

ABL005

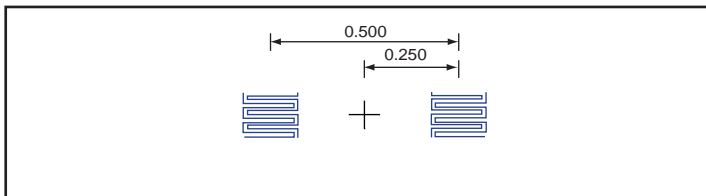

ABL014

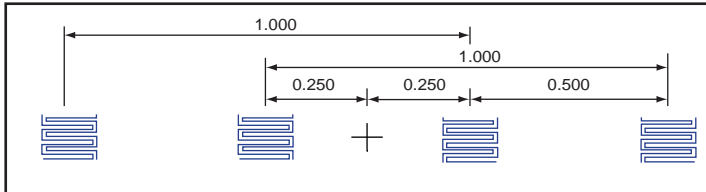

ABL015

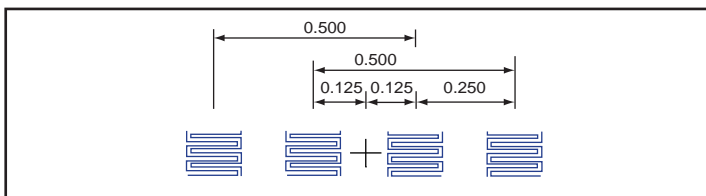

- All dimensions in mm
 - All resistors are 5kΩ
 - Sensor elements are located symmetrically about the center of the IC.
- Note: ABL006 ABL016 Sensor Element Size and Spacing Not Shown**

Schematics:

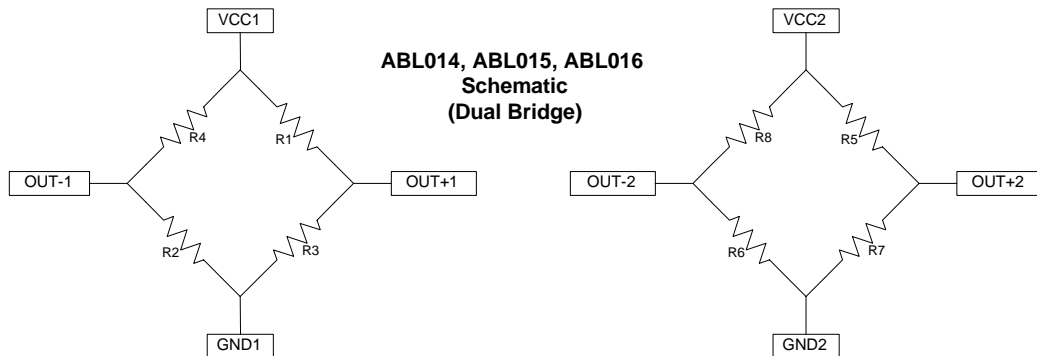
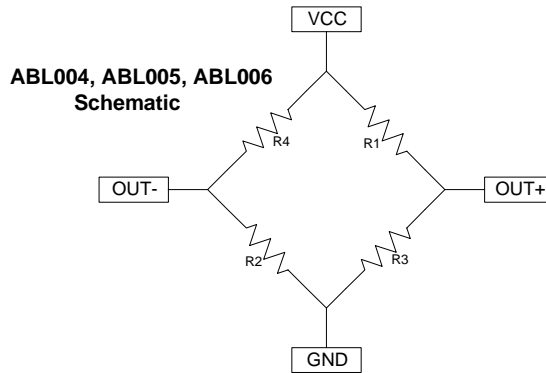

Part Numbers and Configurations:

Part Number	Single or Dual Bridge	Element Spacing (Microns)	Phase Shift Between Bridges (Microns)	Package Marking
ABL004-00	Single	1000	NA	FDB
ABL005-00	Single	500	NA	FDC
ABL006-00	Single	300	NA	FDL
ABL014-00	Dual	1000	500	FDD
ABL015-00	Dual	500	250	FDF
ABL016-00	Dual	300	150	FDM
ABL004-10	Single	1000	NA	FDG
ABL005-10	Single	500	NA	FDH
ABL006-10	Single	300	NA	FDN
ABL014-10	Dual	1000	500	FDJ
ABL015-10	Dual	500	250	FDK
ABL016-10	Dual	300	150	FDP

Packages:

The ABL-Series parts are available in MSOP8 and TDFN6 packages. Please see the package drawing section in the Appendix for dimensions. Please note that for dual differential sensors in the TDFN package the power and ground connections for both bridges are common.

Pin Configuration:

MSOP8 Package

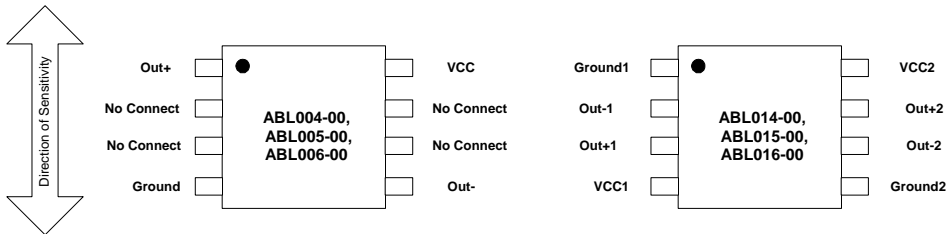

TDFN6 Package

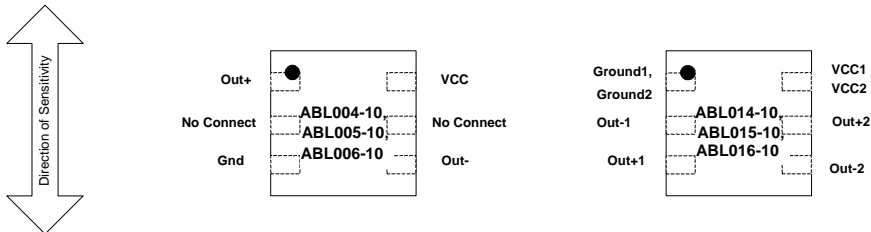

AKL Sensors

Digital Output Gear Tooth And Encoder Sensors

Features:

- Large Airgap
- 50% Duty Cycle
- DC (Zero Speed) Operation
- Precise Spacing Between Sensor Elements
- Excellent Temperature and Voltage Performance
- Small, Low-Profile Surface Mount Package

Applications:

- Anti-lock Brake System Sensors
- Transmission Speed Sensors
- Industrial Linear and Angular Speed Sensing
- Linear and Angular Position Sensing

Description:

NVE offers these products specifically for use as sensors for gear tooth wheels or magnetic encoders with a digital output signal. The pulse output from the sensor corresponds with the gear teeth passing in front of it. When a gear tooth or magnetic pole is in front of the sensor, the sensor's output goes high; when the gear tooth or magnetic pole moves away, the output returns to low. This repeats at every tooth/pole resulting in a pulse train output that provides speed information from the gear or encoder. Three part numbers are currently available: the AKL001-12 is designed for gear teeth or encoders with a pitch of 2.5 to 6 mm, the AKL002-12 for a pitch of 1 to 2.5 mm, and the AKL003-12 for a pitch of 0.6 to 1.5 mm.

In order to minimize the number of wires leading to the sensor, the part is configured as a two-wire device. The two output states are indicated with a change of current through the part. Therefore, when the part is in the digital low state, current is about 3 mA. When the part is in the digital high state, the current increases to about 10 mA. If necessary, the two-wire output of the AKL-Series parts can be easily converted to a three-wire current sinking output with the circuit shown in the GT Sensor applications section.

The parts are rated for the full automotive and industrial temperature range, -40°C to +150°C. They feature reverse battery protection and have an operational voltage range of 4.5V to 36V. They operate from DC to 10 kHz. The parts are available in low-profile, surface mount TDFN SO8 packages.

Specifications:

Parameter	Min	Typ	Max	Unit
Input Voltage	4.5		36	Volts ¹
Supply Current in Off State (Input Voltage=12V)	3.2	4.0	4.8	mA ²
Supply Current in On State (Input Voltage=12V)	7.0	8.0	9.0	mA ²
Output Duty Cycle	40	50	60	%
Operating Temperature Range	-40		+150	°C
AKL001-12 Airgap, Over Full Temperature and Voltage Range ⁴	1.0		3.5	mm
AKL002-12 Airgap, Over Full Temperature and Voltage Range ⁴	1.0		2.5	mm
AKL003-12 Airgap, Over Full Temperature and Voltage Range ⁴	1.0		2.0	mm
Frequency of Operation	0		10K	Hz
ESD		2000		V ³

Absolute Maximum Ratings	
Parameter	Limit
Supply Voltage	45V
Reverse Battery Voltage	-60V
Continuous Output Current	16mA
Junction Temperature Range	-40°C to +170°C
Storage Temperature Range	-65°C to +170°C

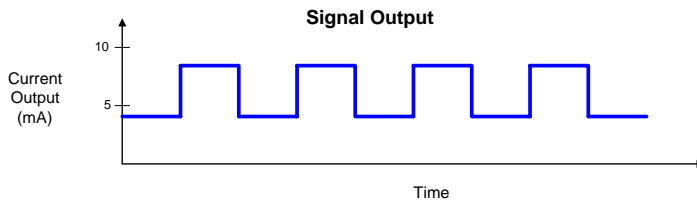

Notes:

1. The supply voltage must appear across the power and ground terminals of the part. Any additional voltage drop due to the presence of a series resistor is not included in this specification.
2. Supply currents can be factory programmed to different levels, for example 3 mA and 6 mA, or 7 mA and 14 mA; contact NVE for details.
3. Pin-to-pin voltage, Human Body Model for ESD
4. Airgap measured with standard ferrous gear tooth; contact NVE for details.

IC Drawings:

The AKL-Series products use the ABL sensor elements described earlier in this section. The AKL001-12 part uses the ABL004 sensor element, the AKL002-12 uses the ABL005 sensor element, and the AKL003-12 uses the ABL006 sensor element. Please see the IC drawings in the ABL-Series section for more information.

Part Numbers and Configurations:

Part Number	Single or Dual Bridge	Element Spacing (Microns)	Marking
AKL001-12	Single	1000	Part Number
AKL002-12	Single	500	Part Number
AKL003-12	Single	300	Part Number

Schematic:

A block diagram of the AKL-Series parts is shown below:

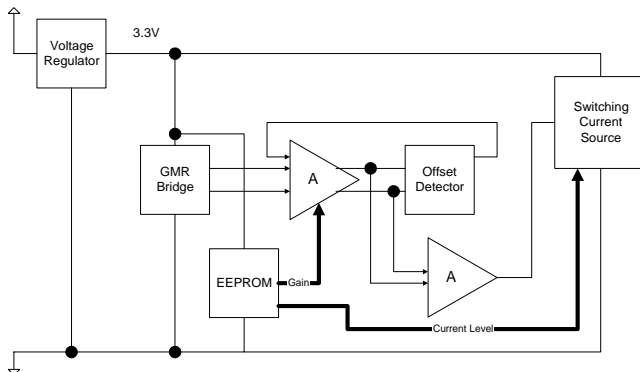

Packages:

The AKL-Series parts are available in the TDFN8 SO8 package. Please see the package drawing section in the Appendix for dimensions.

Pin Configuration:

TDFN8-SO8 Package

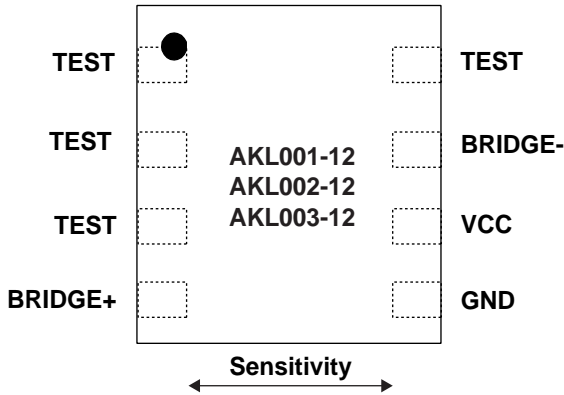

Note: Bridge + and Bridge - are provided for analysis purposes only. NVE does not recommend connecting these pins in a production product for ESD and loading reasons. Also, all pins labeled “Test” must be floating, *i.e.*, not connected to each other or any other circuit node.