

Electro-Static Discharge TUSD05J2U Ultra Low Capacitance TVS Diode

SOT-143

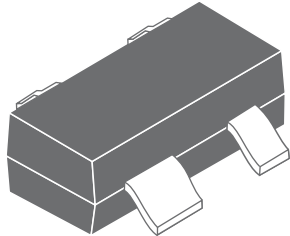

Pin Configuration

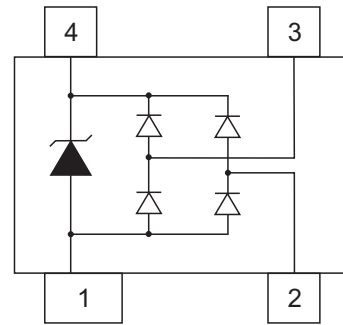

Features

- With TVS Diode
- ESD Protection:Level 4
- Low clamping voltage
- 150 Watts peak pulse power per line(tp=8/20uS)
- Ultra low capacitance:0.8pf max.(any I/O to GND.)
- Protection 2 lines I/O port

IEC Compatibility

- E N61000-4
- IEC61000-4-2(ESD):Level 4,Contact: 8kv,Air: 15kv
- IEC61000-4-4(EFT):40A-5/50ns
- IEC61000-4-5(Surge):4A-8/20μs

Applications

- Lan equipment
- Video
- DVI
- High Speed Data Line
- Ethernet
- USB 2.0 Power and Data line Protection

Mechanical Characteristics

- JEDEC SOT-143 Package
- Molding Compound Flammability Rating:UL 94V-O
- Quantity Per Reel:3000pcs
- Reel Size:7 inch
- Halgen Free

Maximum Ratings($T_A=25^{\circ}\text{C}$ unless otherwise specified)

Parameter	Symbol	Value	Units
IEC 61000-4-2 ESD Voltage	Air Model Contact Model	$V_{\text{ESD}}^{(1)}$	± 15
			± 8
Peak Pulse Power($t_p=8/20\mu\text{s}$)	P_{PP}	150	Watts
Operating Temperature Range	T_J	-55~150	$^{\circ}\text{C}$
Storage Temperature Range	T_{STG}	-55~150	$^{\circ}\text{C}$

(1).Device stressed with ten non-repetitive ESD pulses, Per channel(I/O to GND).

Electrical Characteristics($T_A=25^{\circ}\text{C}$ unless otherwise specified)

TUSD05J2U(Marking:SL3)

Parameter	Symbol	Conditions	Min.	Max.	Units
Reverse Stand-off Voltage	V_{RWM}	Pin 4 to 1		5	V
Reverse Breakdown Voltage	V_{BR}	$I_z=1\text{mA}$, Pin 4 to 1	6		V
Reverse Leakage Current	I_{R}	@ V_{RWM}		1	μA
Forward Voltage	V_{F}	$I_{\text{F}}=15\text{mA}$		1.15	V
Clamping Voltage	V_{C}	$I_{\text{PP}}=1\text{A}$, $t_p=8/20\mu\text{s}$		15	V
Peak Pulse Current	I_{PP}	$t_p=8/20\mu\text{s}$		4	A
Junction Capacitance	$C_{\text{I/O}}$	0Vdc, $f=1\text{MHz}$ Between I/O Pins and GND		0.8	pF

Ratings and Characteristic Curves

Fig.1 Non-repetitive Peak Pulse Power V.S Pulse Time

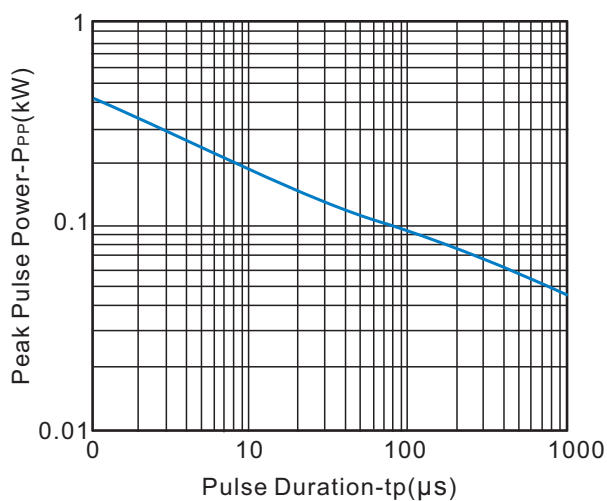
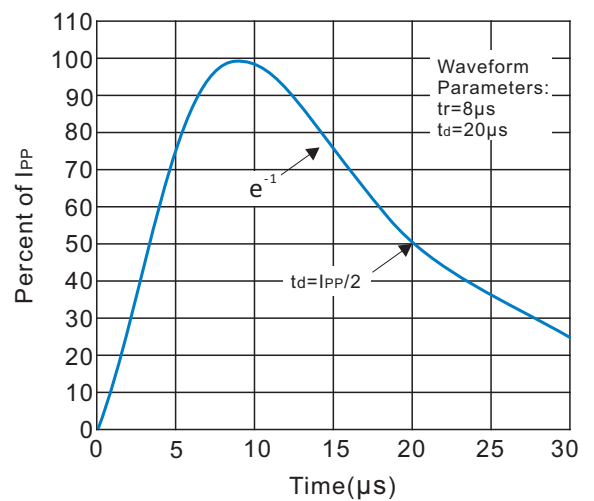
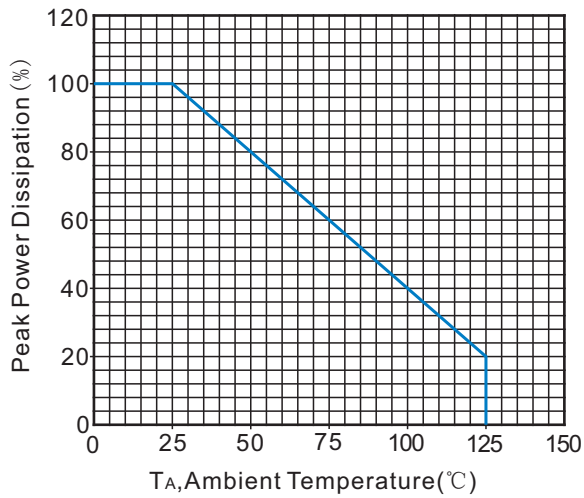

Fig.2 Pulse Waveform



Ratings and Characteristic Curves

Fig.3 Power Derating Curve



Application

USB2.0 Protection

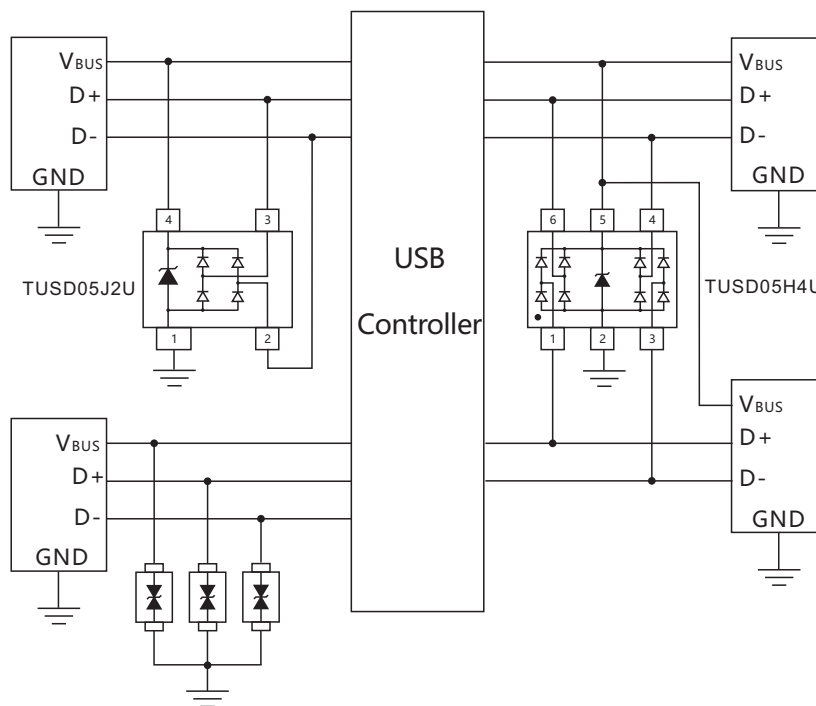

Dimensions(SOT-143)

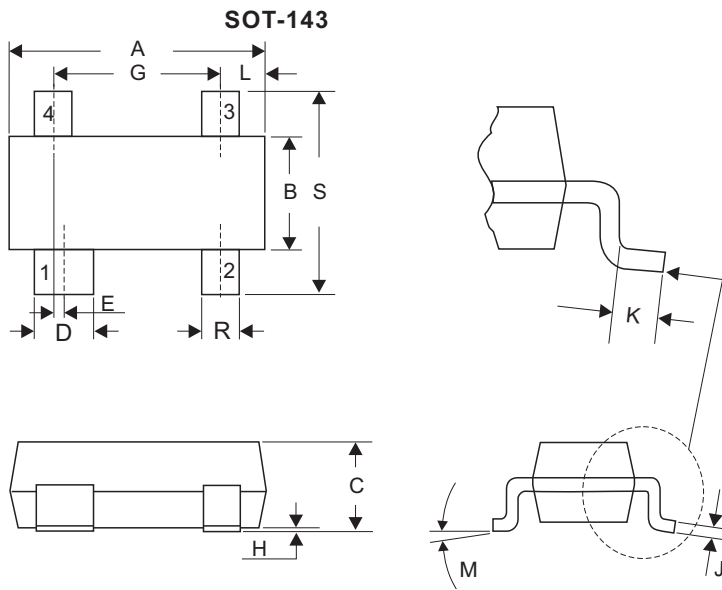

DIM	Millimeters		Inches	
	Min	Max	Min	Max
A	2.667	3.048	0.105	0.120
B	1.194	1.397	0.047	0.055
C	0.787	1.194	0.031	0.047
D	0.762	0.965	0.030	0.038
E	0.200 BSC		0.008 BSC	
G	1.803	2.007	0.071	0.079
H	0.025	0.127	0.001	0.005
J	0.086	0.152	0.0034	0.006
K	0.102	0.305	0.004	0.012
L	0.450	0.600	0.018	0.024
M	0°	10°	0°	10°
R	0.356	0.559	0.014	0.022
S	2.083	2.489	0.082	0.098

Recommended Mounting Pad Layout

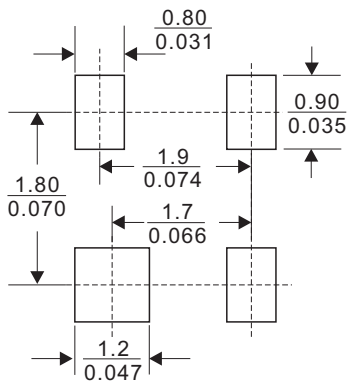

Dimensions in (millimeters)
inches