

4

3

2

1

THIS DRAWING IS UNPUBLISHED. RELEASED FOR PUBLICATION
 © COPYRIGHT - By - ALL RIGHTS RESERVED.

LOC	DIST	REVISIONS					
		P	LTR	DESCRIPTION	DATE	DWN	APVD
HB	-		D	CHANGE LOGO, VENT HOLE; ADD CQC, LINE IDENTIFIER AND PLATING THICKNESS ECO-12-005725	21-AUG-12	D.L	BH.Y

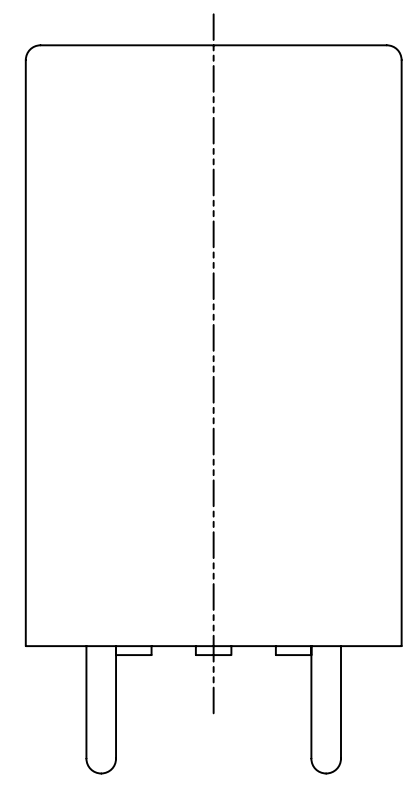
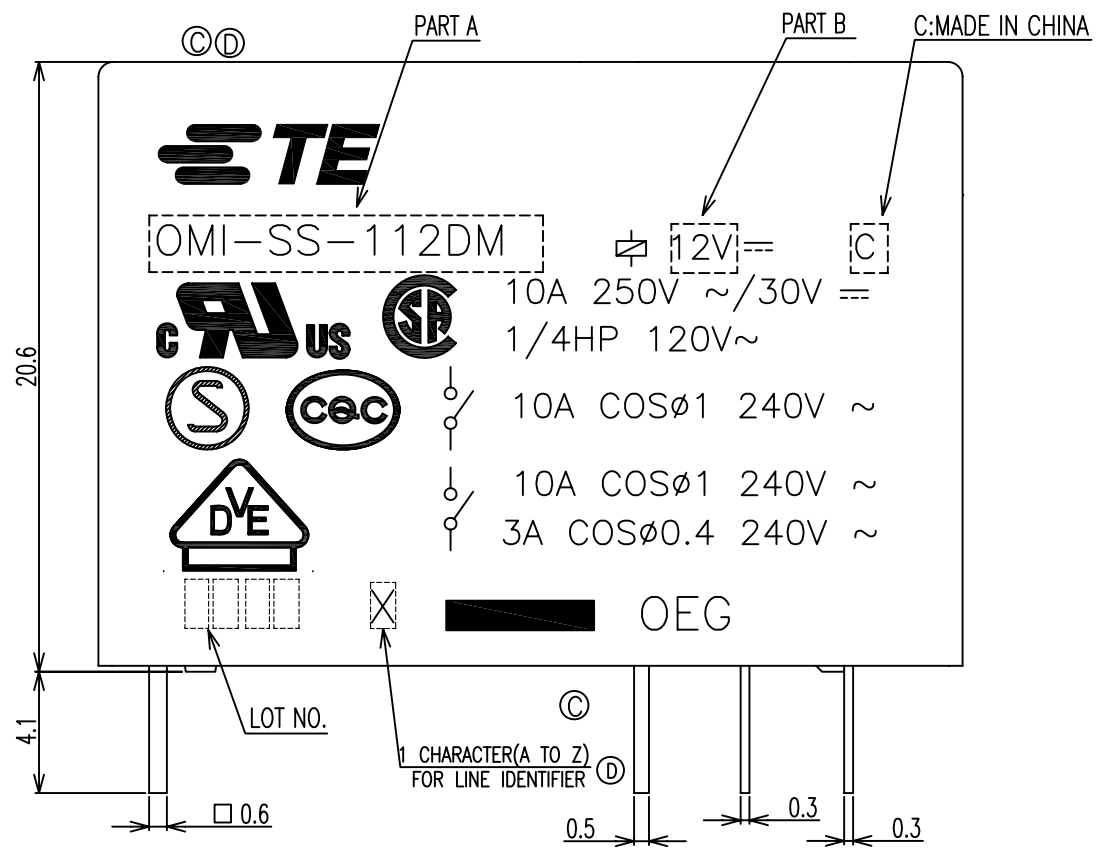
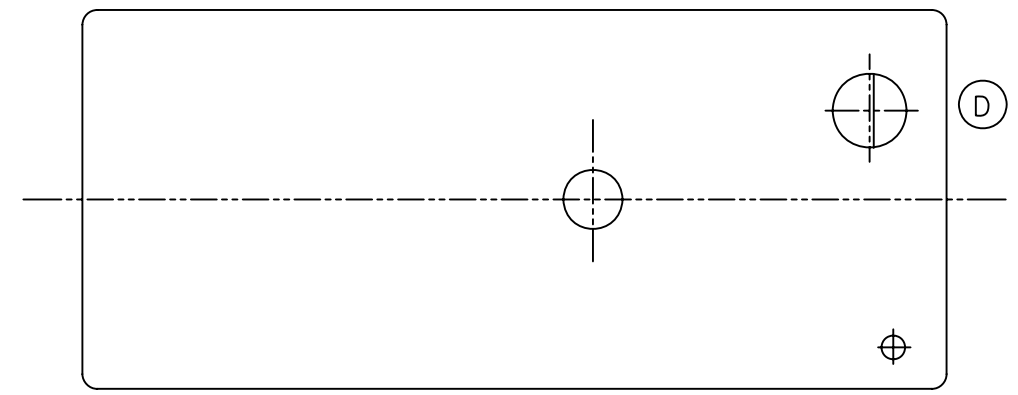

NOTES:
 1.-SS- : PLASTIC SEALD TYPE
 2.LOT NO. SYSTEM AS FOLLOWING:

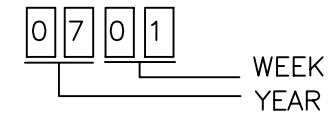

3.GENERAL TOLERANCE AS FOLLOWING:

TOLERANCE	
0~0.99mm	±0.1
1mm~2.99mm	±0.2
3mmMIN.	±0.3

④ 4.TERMINAL DIMENSION IS NOT INCLUDING SOLDER TIP.
 FOR THE TIN-PLATING OF THE PINS:
 +0.1mm FOR WIDTH,THICKNESS AND DIAMETER.
 +0.5mm FOR LENGTH.

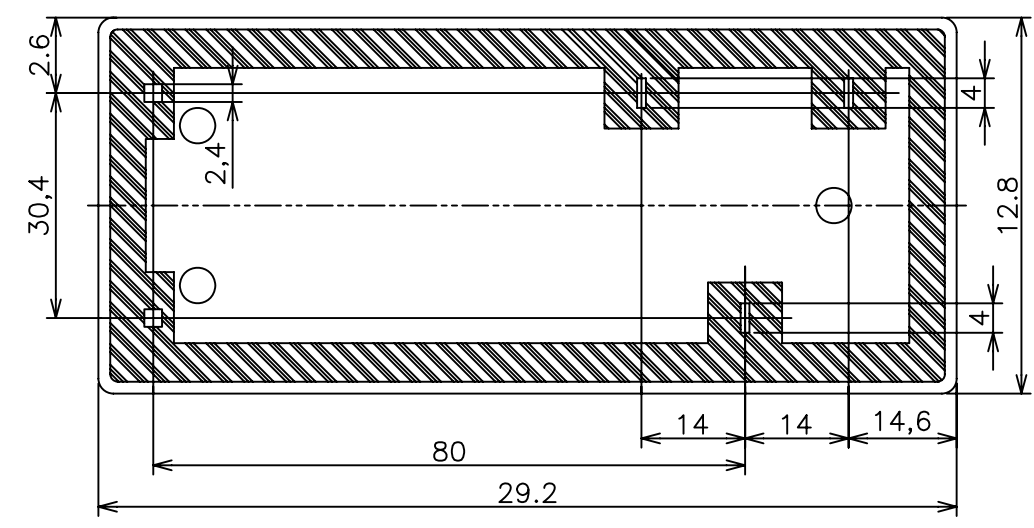

THIS DRAWING IS A CONTROLLED DOCUMENT.		DWN H.SASAKI		TE Connectivity	
DIMENSIONS: mm		CHK Y.OIKAWA			
TOLERANCES UNLESS OTHERWISE SPECIFIED:		APVD A.NAGAI		NAME	
0 PLC ± -		PRODUCT SPEC		-	
1 PLC ± -		APPLICATION SPEC		-	
2 PLC ± -		WEIGHT		-	
3 PLC ± -		CUSTOMER DRAWING		-	
4 PLC ± -		SCALE 4:1		SHEET 1 of 2	
ANGLES ± -		DRAWING NO. A3 00779 C-8-1419144-0		RESTRICTED TO	
FINISH		REV D		-	

4

3

2

1

THIS DRAWING IS UNPUBLISHED.

RELEASED FOR PUBLICATION

-. - .

© COPYRIGHT - By -

ALL RIGHTS RESERVED.

LOC	DIST	REVISIONS					
HB	-	P	LTR	DESCRIPTION	DATE	DWN	APVD

CONNECTION DIAGRAM (BOTTOM VIEW)



DRILLING DIAGRAM(2/1) (BOTTOM VIEW)

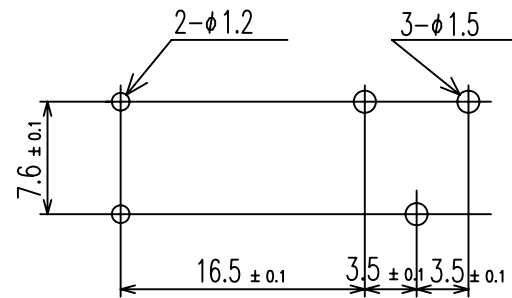

6-1419122-5	OMI-SS-148L	48V	OMI-SS-148L
8-1419144-7	OMI-SS-148D	48V	OMI-SS-148D
8-1419144-5	OMI-SS-136D	36V	OMI-SS-136D
6-1419122-0	OMI-SS-124L	24V	OMI-SS-124L
5-1419122-8	OMI-SS-124D	24V	OMI-SS-124D
5-1419122-3	OMI-SS-112L	12V	OMI-SS-112L
5-1419122-1	OMI-SS-112D	12V	OMI-SS-112D
5-1419122-0	OMI-SS-109L	9V	OMI-SS-109L
4-1419122-8	OMI-SS-106L	6V	OMI-SS-106L
8-1419144-2	OMI-SS-106D	6V	OMI-SS-106D
4-1419122-6	OMI-SS-105L	5V	OMI-SS-105L
8-1419144-0	OMI-SS-105D	5V	OMI-SS-105D
PART NO	TE TYPE NAME	PART B	PART A

RELAY TYPE

		EPOXY RESIN	RESIN	17
UL94 V-0		PBT	CASE	16
		-	TAPE	15
CLASS E		UEW	MAGNETIC WIRE	14
UL94 V-0		PET	BASE	13
UL94 V-0		PBT	BOBBIN	12
	SOLDER DIP	CP WIRE	COIL TERMINAL	11
UL94 V-0		PPS	CARD	10
		Ag ALLOY	MOVABLE CONTACT	9
		Ag ALLOY	STATIONARY CONTACT	8
		Cu ALLOY	HINGE SPRING	7
	SOLDER DIP	Cu ALLOY	B TERMINAL	6
	SOLDER DIP	Cu ALLOY	M TERMINAL	5
	SOLDER DIP	Cu ALLOY	MOVABLE SPRING	4
		STEEL	CORE	3
		STEEL	ARMATURE	2
		STEEL	YOKE	1
INCOMBUSTIBILITY	TREATMENT	MATERIAL	DESCRIPTION	ITEM

THIS DRAWING IS A CONTROLLED DOCUMENT.		DWN H.SASAKI	TE Connectivity														
DIMENSIONS: mm		CHK Y.OIKAWA															
TOLERANCES UNLESS OTHERWISE SPECIFIED:		APVD A.NAGAI	NAME -														
<table border="1"> <tr><td>0 PLC</td><td>± -</td></tr> <tr><td>1 PLC</td><td>± -</td></tr> <tr><td>2 PLC</td><td>± -</td></tr> <tr><td>3 PLC</td><td>± -</td></tr> <tr><td>4 PLC</td><td>± -</td></tr> <tr><td>ANGLES</td><td>± -</td></tr> </table>		0 PLC	± -	1 PLC	± -	2 PLC	± -	3 PLC	± -	4 PLC	± -	ANGLES	± -	PRODUCT SPEC -	OMI-SS-D/L CUSTOMER DRAWING		
0 PLC	± -																
1 PLC	± -																
2 PLC	± -																
3 PLC	± -																
4 PLC	± -																
ANGLES	± -																
MATERIAL -		FINISH -	APPLICATION SPEC -	SIZE A3	CAGE CODE 00779	DRAWING NO C-8-1419144-0	RESTRICTED TO -										
CUSTOMER DRAWING			WEIGHT -	SCALE 4:1	SHEET 2 of 2	REV D											