

## Six Channel SiC MOSFET Driver

### Gate Driver for 1200V SiC MOSFET Power Module

#### Features

- 6 output channels
- Isolated power supply
- Direct mount low inductance design
- Short circuit protection
- Over temperature protection
- Under voltage protection

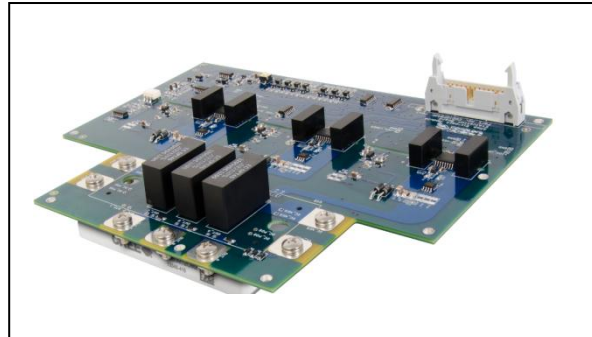

#### For use with Cree Module

- 45mm, 6-pak modules.

#### Applications

- 6-pak Driver for 1.2kV, SiC MOSFET modules
- DC Bus voltage up to 900VDC

Part Number	Package	Marking
CGD15FB45P	PCBA	CGD15FB45P Rev2

#### Absolute Maximum Ratings

Symbol	Parameter	Value	Unit	Test Conditions	Note
$V_s$	Power Supply Voltage	16	V	$V_s$ ramp rate $>50V/sec$	
$V_{iH}$	Input signal voltage HIGH	5	V		
$V_{iL}$	Input signal voltage LOW	0	V		
$I_{O.pk}$	Output peak current	9	A		
$I_{O.avg.ma}$	Output average current	2	A		
$F_{Max}$	Max. Switching frequency	150	kHz	$V_g = +20/-5, R_g = 10 \Omega$	
$V_{DS}$	Max. Drain to source voltage	1200	V		
$V_{isol}$	Input to output isolation voltage	$\pm 1200$	V		
$T_{op}$	Operating temperature	-25 to 70	$^{\circ}C$		
$T_{stg}$	Storage temperature	-40 to 85	$^{\circ}C$		

#### Characteristics

Symbol	Parameter	Value			Unit	Test Conditions	Notes
		Min	Typ	Max			
$V_s$	Supply voltage	13.0	15.0	16.0	V		
$V_i$	Input signal voltage on/off		5/0		V		
$I_{SO}$	Supply current (no load)		330	420	mA	70C	
	Supply current (switching)		830	1000		70C, 150kHz	
$V_{iT+}$	Input threshold voltage HIGH	3.5			V		
$V_{iT-}$	Input threshold voltage LOW			1.5	V		
$T_{don}$	Turn on propagation delay		210	280	nS		
$T_{doff}$	Turn off propagation delay		225	295	nS		
$T_{err}$	Pulse width for resetting fault	800			nS		
$W$	Weight		300		g		
MTBF	Mean time between failure		1.5		$10^6$ h		

## Driver Overview

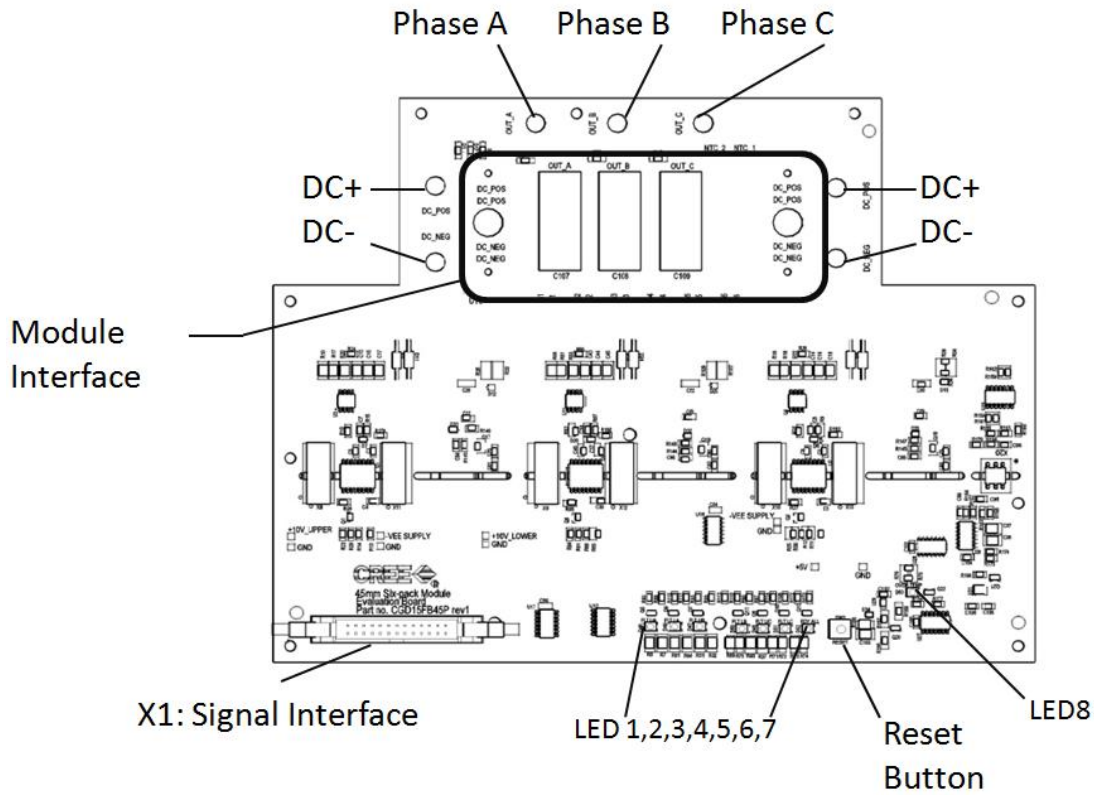

## Block Diagram

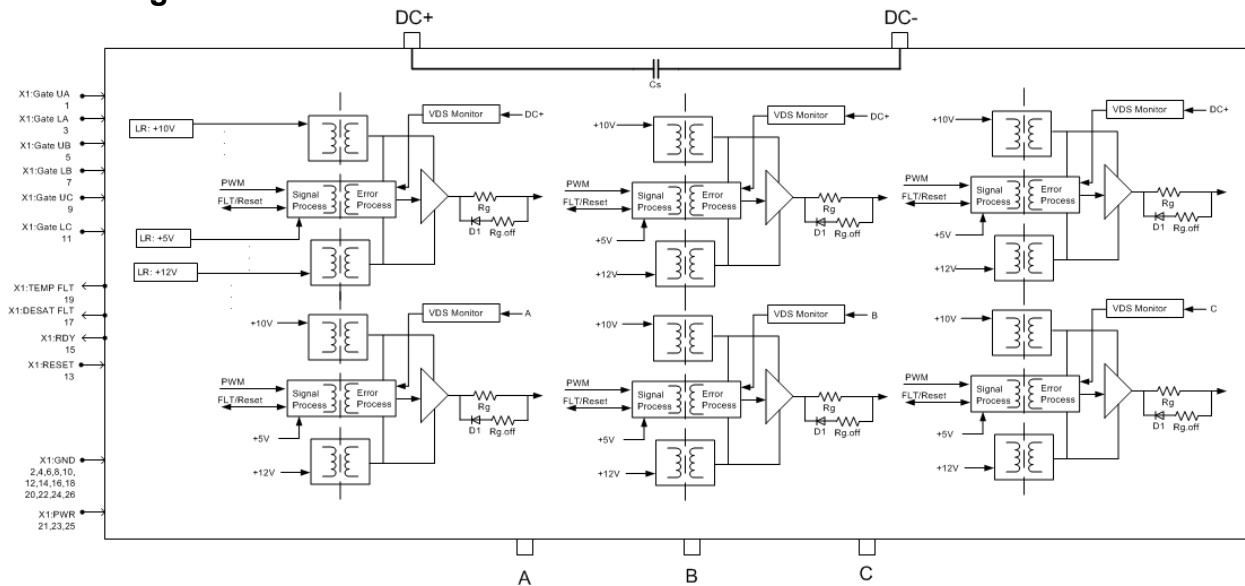

**Note:** Default gate resistor for  $R_g$  is  $10\Omega$  for gate ON and OFF. The user can control the gate turn ON and OFF speed by changing  $R_g$  to a lower value and gain better MOSFET switching efficiency. The user can also control the Gate turn-ON and OFF speed independently by populating  $R_{g.off}$  and D1.  $C_s$  is made up of  $3 \times 2.2nF$ ,  $1.2kV$  film capacitors.

**X1 – 26 pos Signal connector (FCI p/n# 71918-126LF)**

1	PWM_Upper_A (5V Logic)	2	COMMON
3	PWM_Lower_A (5V Logic)	4	
5	PWM_Upper_B (5V Logic)	6	
7	PWM_Lower_B (5V Logic)	8	
9	PWM_Upper_C (5V Logic)	10	
11	PWM_Lower_C (5V Logic)	12	
13	/RST (normally hi)	14	
15	RDY (normally hi)	16	
17	DESAT_FAULT (normally low)	18	
19	OVER_TEMP_FLT (normally low)	20	
21		22	
23	PWR In (Vs)	24	
25		26	

LED Status Indicators			
<b>L1</b>	RED led, illuminated when Phase A upper switch has a desat fault.	<b>L2</b>	RED led, illuminated when Phase A lower switch has a desat fault.
<b>L3</b>	RED led, illuminated when Phase B upper switch has a desat fault.	<b>L4</b>	RED led, illuminated when Phase B lower switch has a desat fault.
<b>L5</b>	RED led, illuminated when Phase C upper switch has a desat fault.	<b>L6</b>	RED led, illuminated when Phase C lower switch has a desat fault.
<b>L7</b>	GREEN led, illuminated when power is present and all faults are clear.	<b>L8</b>	RED led, illuminated when there is an over temp fault.

### Fault Handling

Each of the six gate drive channels is protected by a desaturation circuit. In the event of a short circuit, the voltage across the MOSFET ( $V_{DS}$ ) rises until it hits a threshold which causes the desaturation circuit to drive all six gate drive channels to their off state. Pin 17 of the 26 pin main signal connector toggles high when a desaturation event occurs. There will also be a red LED (L1-L6) illuminated for the gate drive channel(s) that activated the desaturation protection. Once the fault is cleared, the circuit can be reset with the onboard reset button or remotely by pulling pin 13 of the 26 pin ribbon connector to common.

There is an overtemperature protection circuit that turns off all the gates in the event an overtemperature is detected. The overtemperature circuit reads the value of the six pack module's onboard NTC. When the NTC reaches a value corresponding to 115C, the overtemperature circuit is activated and all six gate drive channels are driven to their low state. Pin 19 of the 26 pin ribbon connector is toggled high when an overtemperature fault occurs.

### Typical Application

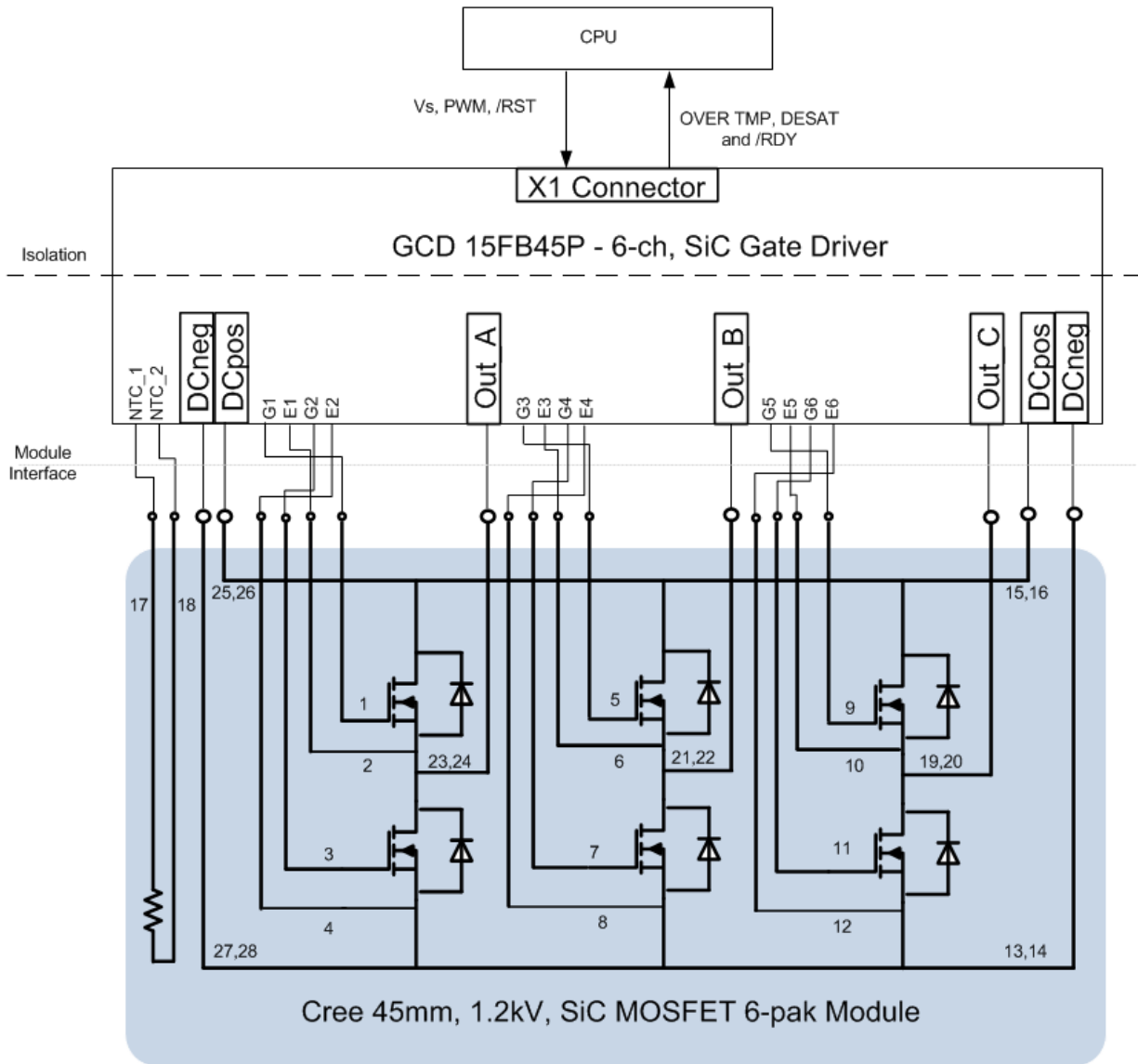

## Mechanical Instructions

Designed to directly mount to Cree 45 mm style power modules, the 6-ch gate driver also has several other mounting holes to secure the assembly.

Attach the gate driver board to the power module via the 4x Module screw holes (see diagram below) using the recommended hardware in Table 1. Then solder the 28x solder pins via the solder pin holes to electrically connect the driver board to the power module. The solder must not exceed 260°C and the solder per pin must not exceed 10 seconds. The solder joints should be in accordance with IPC A 610 Rev D (or later) – Class 3 to ensure an optimal connection between the module and gate driver board.

The module plus driver board assembly must be further supported by securing the assembly to standoffs via the 9x Mounting holes shown in the figure below.

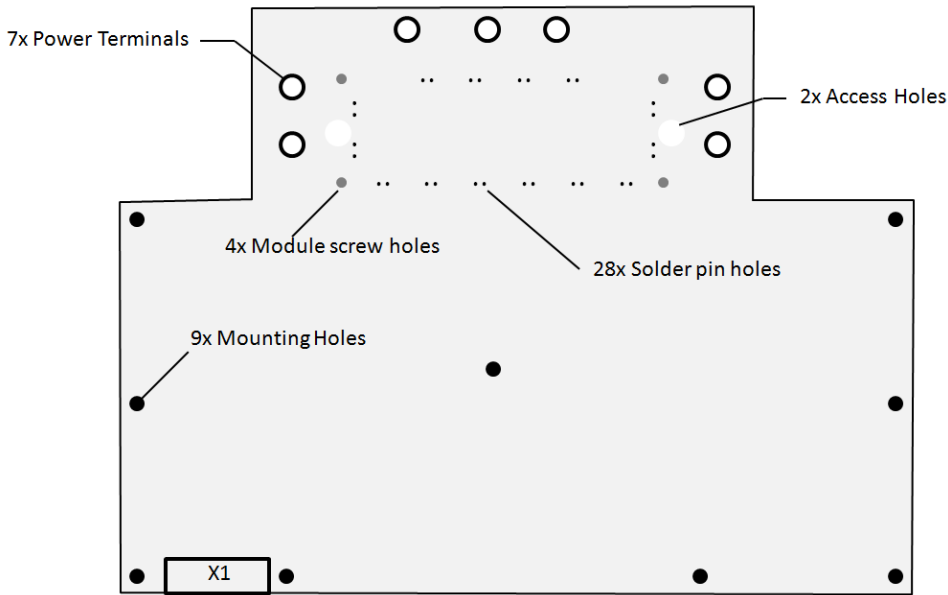
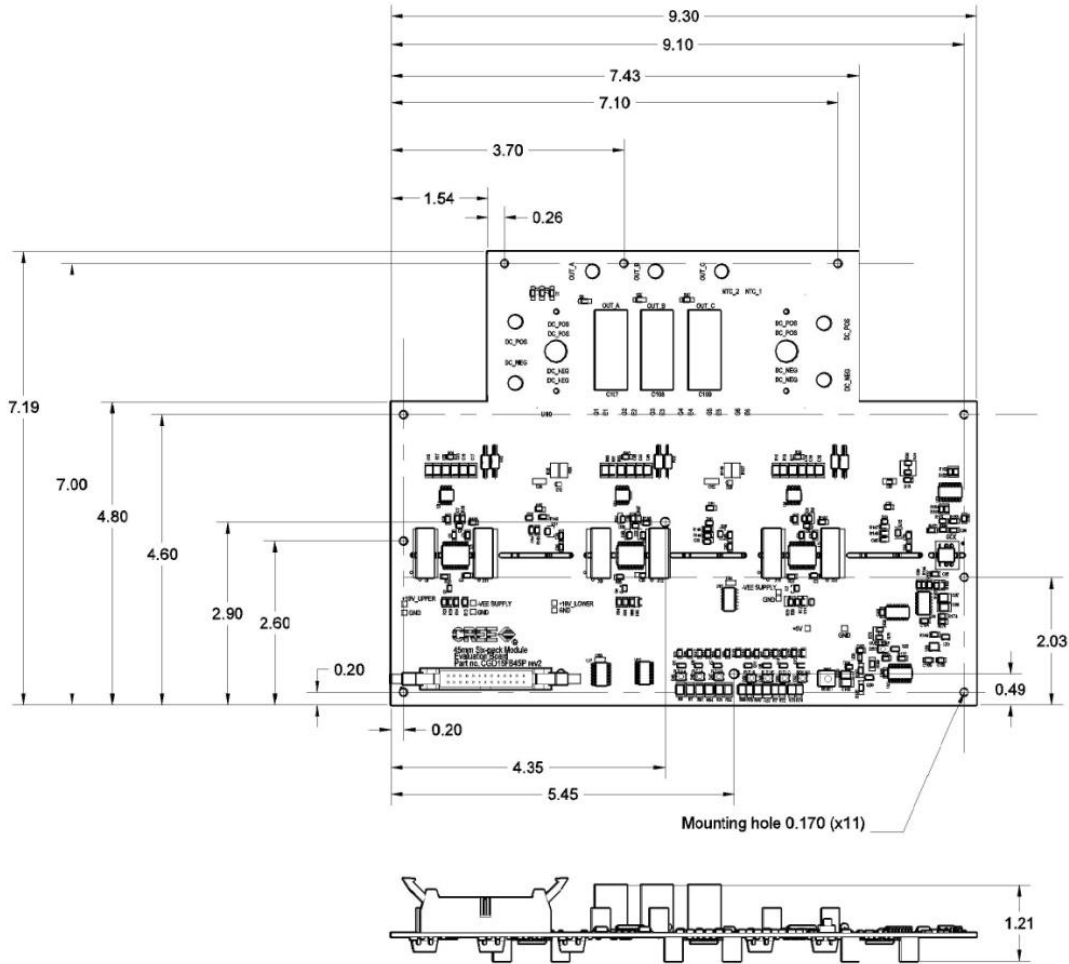

**Table 1 Hardware List**

Ref	Description	Hardware	Locations	Torque
Module screw holes	2.5mm clearance holes for mounting screws to secure the module to the printed circuit board assembly.	M2.5 x 4mm	4x	0.5 Nm
Mounting holes	4.3mm clearance holes for screws to secure the circuit assembly to stand-offs for additional support.	6-32 x 5/6" Zinc Plated pan head screw /w internal tooth washer.	9x	0.9 Nm
Access holes	10mm clearance hole to provide access to the screw that secures the module to the heatsink.	n/a	2x	n/a
Solder pin holes	1.6mm plated holes for solder pins from power module.	Solder pins from power module	28x	n/a
Power terminals	5mm holes to secure power cables.	*	7x	

\* Power terminal holes are sized to accept a PENN broaching nut (#P-KFS2-032). A 10-32, 6mm screw with a captured lock washer should be used with this broaching nut.

### Mechanical Drawing (units in Inches)



This product has not been designed or tested for use in, and is not intended for use in, applications implanted into the human body nor in applications in which failure of the product could lead to death, personal injury or property damage, including but not limited to equipment used in the operation of nuclear facilities, life-support machines, cardiac defibrillators or similar emergency medical equipment, aircraft navigation or communication or control systems, air traffic control systems, or weapons systems.

Copyright © 2014 Cree, Inc. All rights reserved. The information in this document is subject to change without notice. Cree and the Cree logo are registered trademarks and Z-REC and Z-FET are trademarks of Cree, Inc.

Cree, Inc.  
 4600 Silicon Drive  
 Durham, NC 27703  
 USA Tel: +1.919.313.5300  
 Fax: +1.919.313.5451  
[www.cree.com/power](http://www.cree.com/power)