

GL382

IrDA-Based SIR System-Conforming Infrared Emitting Diode

■ Features

1. Compact 3 ϕ resin mold package
2. Peak emitting wavelength conforming to SIR system based on IrDA
($\lambda_p=880$ nm [$I_F=50$ mA])
3. Narrow beam angle
(Half intensity angle : TYP. $\pm 17^\circ$)
4. High speed response
(Cut-off frequency f_c : TYP.12MHz)

■ Applications

1. Portable information terminal equipment
2. Personal computers
3. Printers

■ Absolute Maximum Ratings

(Ta=25°C)

Parameter	Symbol	Rating	Unit
Forward current	I_F	60	mA
*1 Peak forward current	I_{FM}	0.5	A
Reverse voltage	V_R	4	V
Operating temperature	T_{opr}	- 25 to + 85	°C
Storage temperature	T_{stg}	- 40 to + 85	°C
*2 Soldering temperature	T_{sol}	260	°C

■ Outline Dimensions

(Unit : mm)

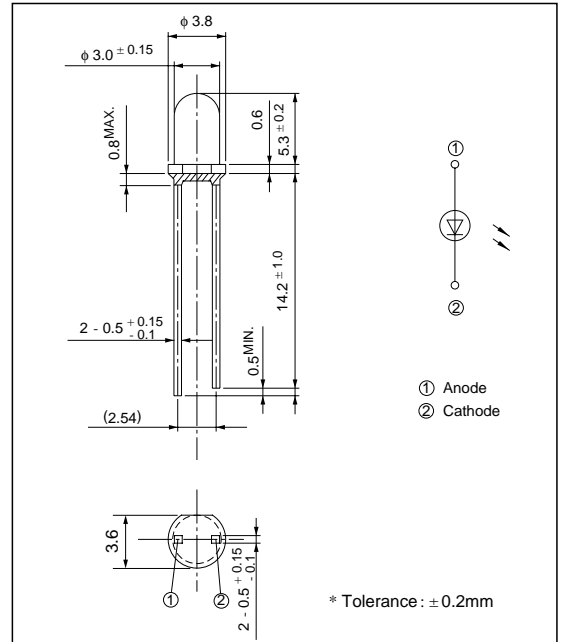
*1 Pulse width $\leq 100 \mu$ s, Duty ratio=0.01

*2 For 3 seconds at the position of 2.6 mm from the resin edge

■ Electro-optical Characteristics

(Ta=25 °C)

Parameter	Symbol	Conditions	MIN.	TYP.	MAX.	Unit
Forward voltage	V_F	$I_F = 50$ mA	-	1.5	1.7	V
Peak forward voltage	V_{FM}	$I_{FM} = 0.5$ A	-	2.2	3.8	V
Reverse voltage	I_R	$V_R = 3$ V	-	-	10	μ A
*3 Radiant intensity	I_E	$I_F = 50$ mA	6	18	-	mW/sr
Peak emission wavelength	λ_p	$I_F = 50$ mA	-	880	-	nm
Half intensity wavelength	$\Delta \lambda$	$I_F = 50$ mA	-	40	-	nm
Response frequency	f_c	$I_F=50$ mA+ 10 mA $_{p-p}$	-	12	-	MHz
Half intensity angle	$\Delta \theta$	$I_F = 20$ mA	-	± 17	-	°

*3 I_E : Value obtained by converting the value in power of radiant fluxes emitted at the solid angle of 0.01 sr (steradian) in the direction of mechanical axis of the lens portion into 1 sr or all those emitted from the light emitting diode.

Fig. 1 Forward Current vs. Ambient Temperature

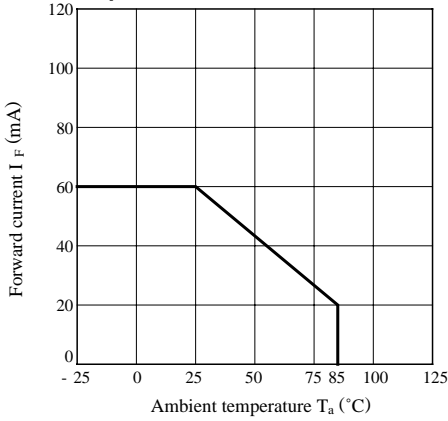

Fig. 2 Peak Forward Current vs. Duty Ratio

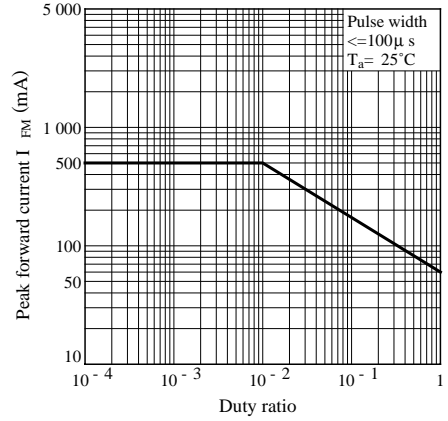

Fig. 3 Spectral Distribution

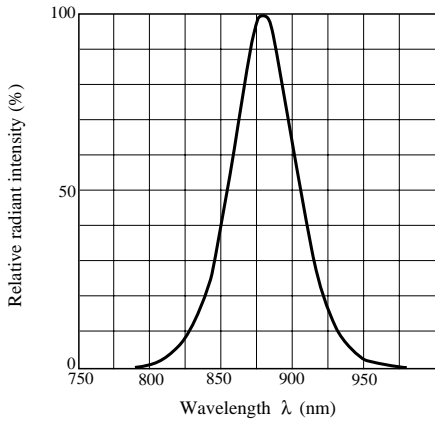

Fig. 4 Peak Emission Wavelength vs. Ambient Temperature

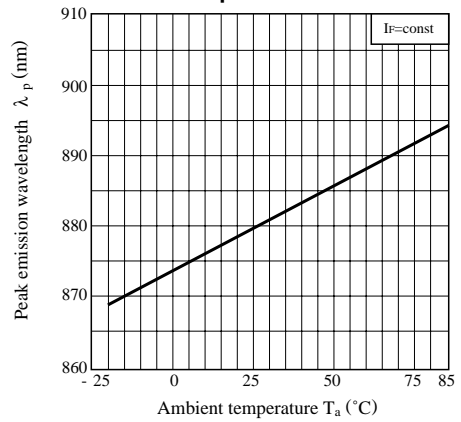

Fig. 5 Forward Current vs. Forward Voltage

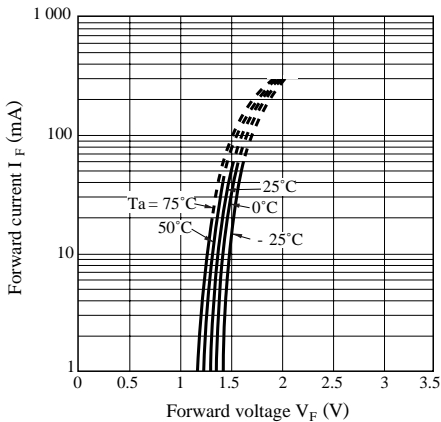

Fig. 6 Relative Radiant Flux vs. Ambient Temperature

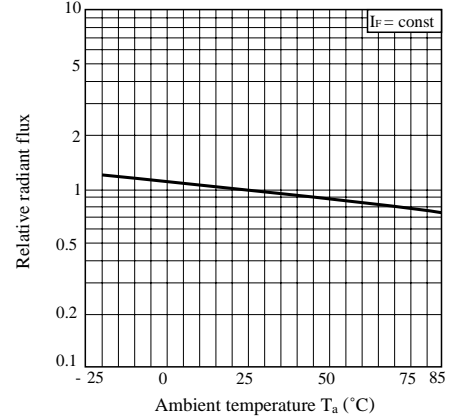

Fig. 7 Radiant Intensity vs. Forward Current

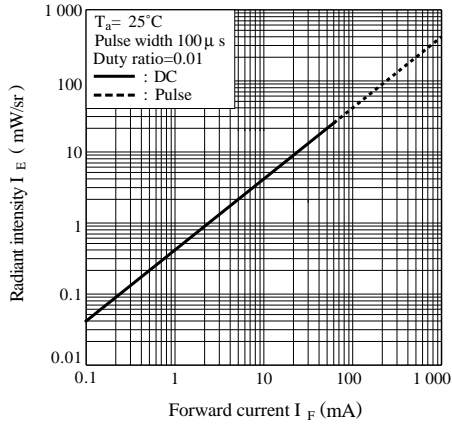
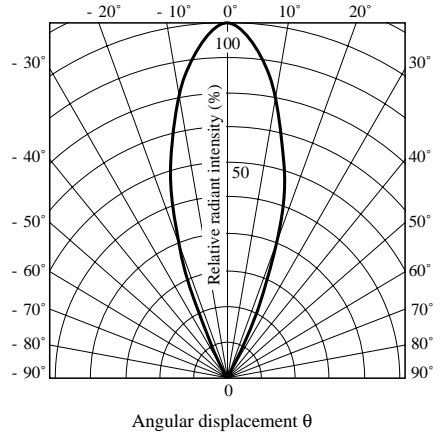

Fig. 8 Radiation Diagram



● Please refer to the chapter "Precautions for Use". (Page 78 to 93)