

## Low voltage 16-bit constant current LED sink driver with balanced output rise/fall time

Datasheet - production data

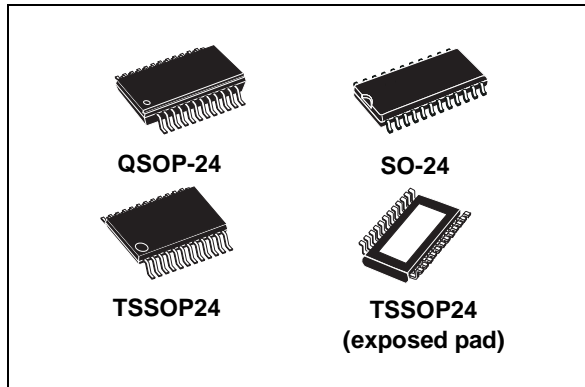

### Description

The STP16CPC05 is a monolithic, low voltage, low current power 16-bit shift register designed for LED panel displays. The STP16CPC05 contains a 16-bit serial-in, parallel-out shift register that feeds a 16-bit, D-type storage register. In the output stage, sixteen regulated current sources provide from 5 mA to 100 mA constant current to drive the LEDs. The STP16CPC05's output stage is designed to optimize the turn-on and turn-off time, typically 100 nS. The balanced turning ON/OFF improves the system performances reducing the bypass capacitance in applications where parasitic inductance generate ringing or noise in the system. The LEDs' brightness can be controlled by using an external resistor to adjust the STP16CPC05 output current. The STP16CPC05 guarantees a 20 V output driving capability, allowing users to connect more LEDs in series. The high clock frequency, 30 MHz, makes the device suitable for high data rate transmission. The 3.3 V voltage supply is useful in applications that interface with a 3.3 V microcontroller

### Features

- Low voltage power supply down to 3 V
- 16 constant current output channels
- Adjustable output current through external resistor
- Serial data IN/parallel data OUT
- Can be driven by a 3.3 V microcontroller
- Output current: 5-100 mA
- Max clock frequency 30 MHz
- ESD protection 2.5 kV HBM, 200 V MM

Table 1. Device summary

Order codes	Package	Packaging
STP16CPC05MTR	SO-24	1000 parts per reel
STP16CPC05TTR	TSSOP24	2500 parts per reel
STP16CPC05XTTR	TSSOP24 exposed pad	2500 parts per reel
STP16CPC05PTR	QSOP-24	2500 parts per reel

# Contents

<b>1</b>	<b>Summary description</b> .....	<b>3</b>
1.1	Pin connection and description .....	3
<b>2</b>	<b>Electrical ratings</b> .....	<b>5</b>
2.1	Absolute maximum ratings .....	5
2.2	Thermal data .....	5
2.3	Recommended operating conditions .....	6
<b>3</b>	<b>Electrical characteristics</b> .....	<b>7</b>
<b>4</b>	<b>Equivalent circuit and outputs</b> .....	<b>9</b>
<b>5</b>	<b>Timing diagrams</b> .....	<b>11</b>
<b>6</b>	<b>Typical characteristics</b> .....	<b>14</b>
<b>7</b>	<b>Test circuit</b> .....	<b>17</b>
<b>8</b>	<b>Package mechanical data</b> .....	<b>20</b>
<b>9</b>	<b>Packaging mechanical data</b> .....	<b>27</b>
<b>10</b>	<b>Revision history</b> .....	<b>29</b>

# 1 Summary description

**Table 2. Typical current accuracy**

Output voltage	Current accuracy		Output current	V <sub>DD</sub>	Temperature
	Between bits	Between ICs			
≥ 1.3 V	±1.5%	±5%	≥ 20 to 100 mA	3.3 V to 5 V	25 °C

## 1.1 Pin connection and description

**Figure 1. Pin connection**

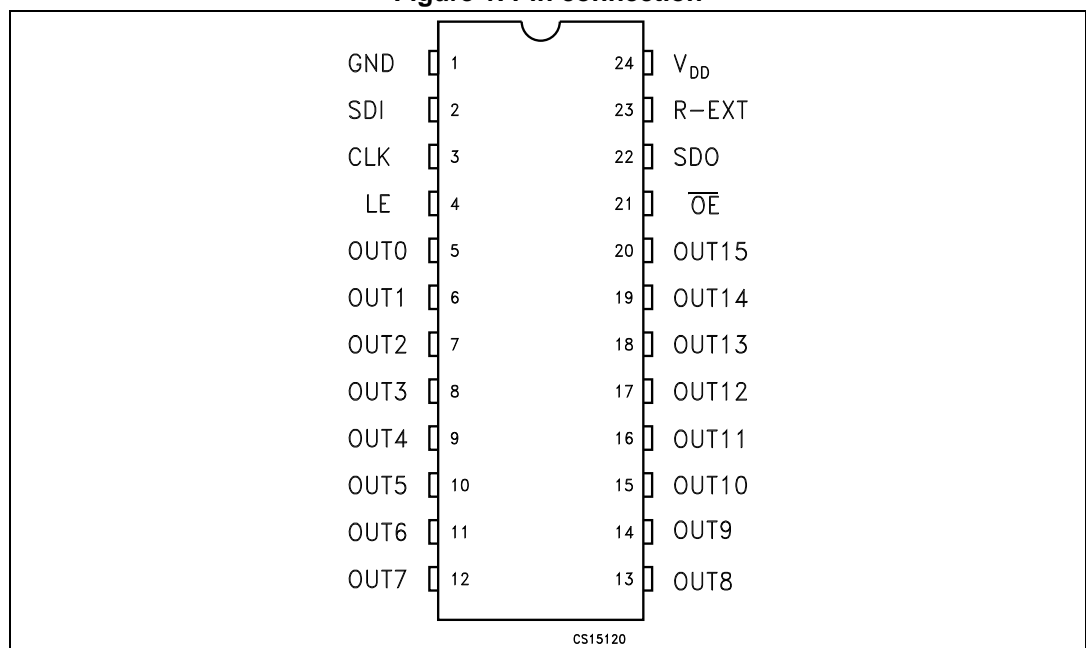

*Note:* Exposed-pad should be electrically connected to a metal land electrically isolated or connected to ground

**Table 3. Pin description**

Pin N°	Symbol	Name and function
1	GND	Ground terminal
2	SDI	Serial data input terminal
3	CLK	Clock input terminal
4	LE	Latch input terminal
5-20	OUT 0-15	Output terminal
21	$\overline{OE}$	Input terminal of output enable (active low)
22	SDO	Serial data out terminal

Table 3. Pin description (continued)

Pin N°	Symbol	Name and function
23	R-EXT	Input terminal of an external resistor for constant current programming
24	V <sub>DD</sub>	Supply voltage terminal

## 2 Electrical ratings

### 2.1 Absolute maximum ratings

Stressing the device above the rating listed in the “absolute maximum ratings” table may cause permanent damage to the device. These are stress ratings only and operation of the device at these or any other conditions above those indicated in the operating sections of this specification is not implied. Exposure to absolute maximum rating conditions for extended periods may affect device reliability.

**Table 4. Absolute maximum ratings**

Symbol	Parameter	Value	Unit
$V_{DD}$	Supply voltage	0 to 7	V
$V_O$	Output voltage	-0.5 to 20	V
$I_O$	Output current	100	mA
$V_I$	Input voltage	-0.4 to $V_{DD}+0.4$	V
$I_{GND}$	GND terminal current	1600	mA
$f_{CLK}$	Clock frequency	50	MHz

### 2.2 Thermal data

**Table 5. Thermal data**

Symbol	Parameter	Value	Unit	
$T_{OPR}$	Operating temperature range	-40 to +125	°C	
$T_{STG}$	Storage temperature range	-55 to +150	°C	
$R_{thJC}$	Thermal resistance junction-case	SO-24	60	°C/W
		TSSOP24	85	°C/W
		TSSOP24 <sup>(1)</sup> exposed pad	37.5	°C/W
		QSOP-24	72	°C/W

1. The exposed pad should be soldered directly to the PCB to realize the thermal benefits.

## 2.3 Recommended operating conditions

Table 6. Recommended operating conditions  $T_A = 25\text{ }^\circ\text{C}$

Symbol	Parameter	Test conditions	Min	Typ	Max	Unit
$V_{DD}$	Supply voltage		3.0	-	5.5	V
$V_O$	Output voltage			-	20	V
$I_O$	Output current	OUTn	3	-	100	mA
$I_{OH}$	Output current	SERIAL-OUT		-	+1	mA
$I_{OL}$	Output current	SERIAL-OUT		-	-1	mA
$V_{IH}$	Input voltage		$0.7V_{DD}$	-	$V_{DD}+0.3$	V
$V_{IL}$	Input voltage		-0.3	-	$0.3V_{DD}$	V
$t_{wLAT}$	LE pulse width	$V_{DD} = 3.3\text{ V to }5.0\text{ V}$	20	-		ns
$t_{wCLK}$	CLK pulse width		16	-		ns
$t_{wEN}$	$\overline{OE}$ pulse width		200	-		ns
$t_{SETUP(D)}$	Setup time for DATA		8	-		ns
$t_{HOLD(D)}$	Hold time for DATA		4	-		ns
$t_{SETUP(L)}$	Setup time for LATCH		5	-		ns
$f_{CLK}$	Clock frequency		Cascade operation <sup>(1)</sup> $V_{DD} = 5\text{ V}$		-	30

1. If the device is connected in cascade, it may not be possible to achieve the maximum data transfer. Please consider the timings carefully.

### 3 Electrical characteristics

$V_{DD} = 3.3 \text{ V to } 5 \text{ V}$ ,  $T_A = 25 \text{ }^\circ\text{C}$ , unless otherwise specified

**Table 7. Electrical characteristics**

Symbol	Parameter	Test conditions	Min	Typ	Max	Unit
$V_{IH}$	Input voltage high level		$0.7V_{DD}$		$V_{DD}$	V
$V_{IL}$	Input voltage low level		GND		$0.3V_{DD}$	V
$I_{OH}$	Output leakage current	$V_{OH} = 20 \text{ V}$			10	$\mu\text{A}$
$V_{OL}$	Output voltage (Serial-OUT)	$I_{OL} = 1 \text{ mA}$			0.4	V
$V_{OH}$	Output voltage (Serial-OUT)	$I_{OH} = -1 \text{ mA}$	$V_{DD}-0.4\text{V}$			V
$I_{OL1}$	Output current	$V_O = 0.3 \text{ V}$ , $R_{ext} = 4.2 \text{ k}\Omega$	4.25	5	5.75	mA
$I_{OL2}$		$V_O = 0.3 \text{ V}$ , $R_{ext} = 1 \text{ k}\Omega$	19	20	21	
$I_{OL3}$		$V_O = 1.3 \text{ V}$ , $R_{ext} = 200 \Omega$	96	100	104	
$\Delta I_{OL1}$	Output current error between bit (All Output ON)	$V_O = 0.3 \text{ V}$ , $R_{ext} = 4.2 \text{ k}\Omega$		$\pm 5$	$\pm 8$	%
$\Delta I_{OL2}$		$V_O = 0.3 \text{ V}$ , $R_{ext} = 1 \text{ k}\Omega$		$\pm 1.5$	$\pm 3$	
$\Delta I_{OL3}$		$V_O = 1.3 \text{ V}$ , $R_{ext} = 200 \Omega$		$\pm 1.2$	$\pm 3$	
$R_{SIN(up)}$	Pull-up resistor		150	300	600	$\text{k}\Omega$
$R_{SIN(down)}$	Pull-down resistor		100	200	400	$\text{k}\Omega$
$I_{DD(OFF1)}$	Supply current (OFF)	$R_{EXT} = 1 \text{ k}\Omega$ OUT 0 to 15 = OFF		4		mA
$I_{DD(OFF2)}$		$R_{EXT} = 250 \Omega$ OUT 0 to 15 = OFF		11.2		
$I_{DD(ON1)}$	Supply current (ON)	$R_{EXT} = 1 \text{ k}\Omega$ OUT 0 to 15 = ON		4.5		
$I_{DD(ON2)}$		$R_{EXT} = 250 \Omega$ OUT 0 to 15 = ON		11.7		
Thermal	Thermal protection			170		$^\circ\text{C}$

V<sub>DD</sub> = 5 V, T<sub>A</sub> = 25 °C, unless otherwise specified

Table 8. Switching characteristics

Symbol	Parameter	Test conditions	Min	Typ	Max	Unit	
t <sub>PLH1</sub>	Propagation delay time, CLK-OUT <sub>n</sub> , LE = H, $\overline{OE}$ = L	V <sub>IH</sub> = V <sub>DD</sub> V <sub>IL</sub> = GND I <sub>O</sub> = 20 mA R <sub>EXT</sub> = 1 kΩ C <sub>L</sub> = 10 pF V <sub>L</sub> = 3.0 V R <sub>L</sub> = 60 Ω	V <sub>DD</sub> = 3.3 V	-	175	227	ns
			V <sub>DD</sub> = 5 V	-	159	206	
t <sub>PLH2</sub>	Propagation delay time, LE-OUT <sub>n</sub> , $\overline{OE}$ = L		V <sub>DD</sub> = 3.3 V	-	176	228	ns
			V <sub>DD</sub> = 5 V	-	158	205	
t <sub>PLH3</sub>	Propagation delay time, OE-OUT <sub>n</sub> , LE = H		V <sub>DD</sub> = 3.3 V	-	235	305	ns
			V <sub>DD</sub> = 5 V	-	192	250	
t <sub>PLH</sub>	Propagation delay time, CLK-SDO		V <sub>DD</sub> = 3.3 V	-	20	26	ns
			V <sub>DD</sub> = 5 V	-	14	18	
t <sub>PHL1</sub>	Propagation delay time, CLK-OUT <sub>n</sub> , LE = H, $\overline{OE}$ = L		V <sub>DD</sub> = 3.3 V	-	70	91	ns
			V <sub>DD</sub> = 5 V	-	68	88	
t <sub>PHL2</sub>	Propagation delay time, LE-OUT <sub>n</sub> , $\overline{OE}$ = L		V <sub>DD</sub> = 3.3 V	-	56	73	ns
			V <sub>DD</sub> = 5 V	-	54	70	
t <sub>PHL3</sub>	Propagation delay time, OE-OUT <sub>n</sub> , LE = H	V <sub>DD</sub> = 3.3 V	-	102	132	ns	
		V <sub>DD</sub> = 5 V	-	100	130		
t <sub>PHL</sub>	Propagation delay time, CLK-SDO	V <sub>DD</sub> = 3.3 V	-	25	32	ns	
		V <sub>DD</sub> = 5 V	-	17	22		
t <sub>ON</sub>	Output rise time 10~90% of voltage waveform	V <sub>DD</sub> = 3.3 V	-	116	150	ns	
		V <sub>DD</sub> = 5 V	-	108	140		
t <sub>OFF</sub>	Output fall time 90~10% of voltage waveform	V <sub>DD</sub> = 3.3 V	-	80	104	ns	
		V <sub>DD</sub> = 5 V	-	80	104		
t <sub>r</sub>	CLK rise time <sup>(1)</sup>		-		5000	ns	
t <sub>f</sub>	CLK fall time <sup>(1)</sup>		-		5000	ns	

1. In order to achieve high cascade data transfer, please consider tr/ff timings carefully.



## 4 Equivalent circuit and outputs

Figure 2.  $\overline{OE}$  terminal

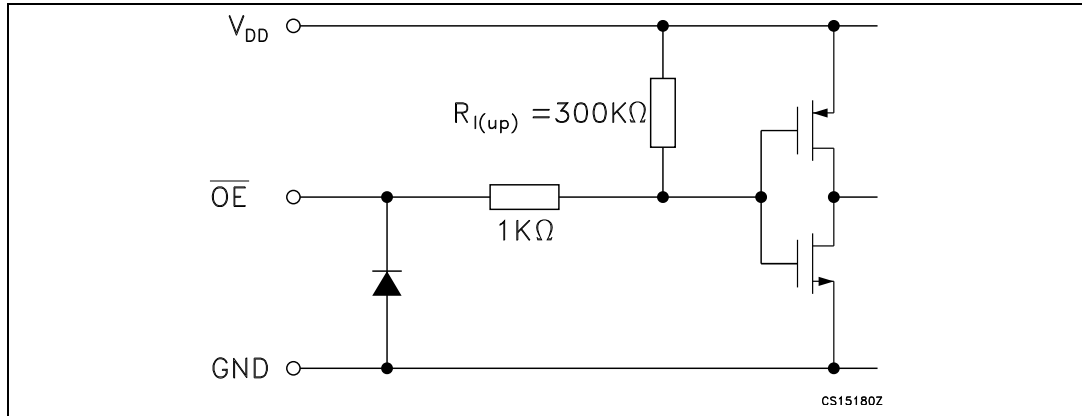

Figure 3. LE terminal

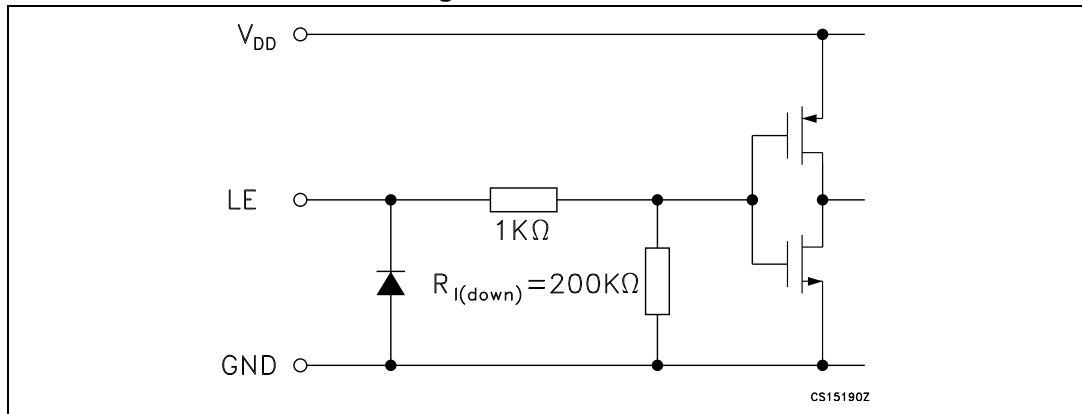

Figure 4. CLK, SDI terminal

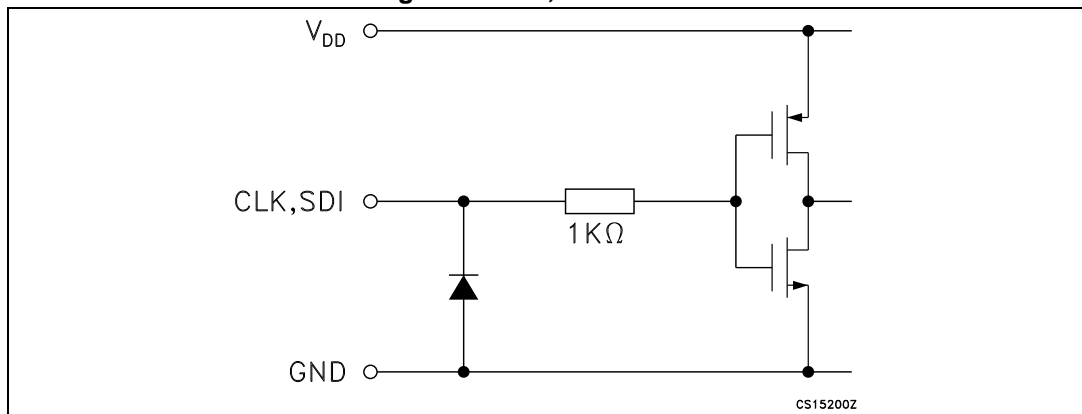

Figure 5. SDO terminal

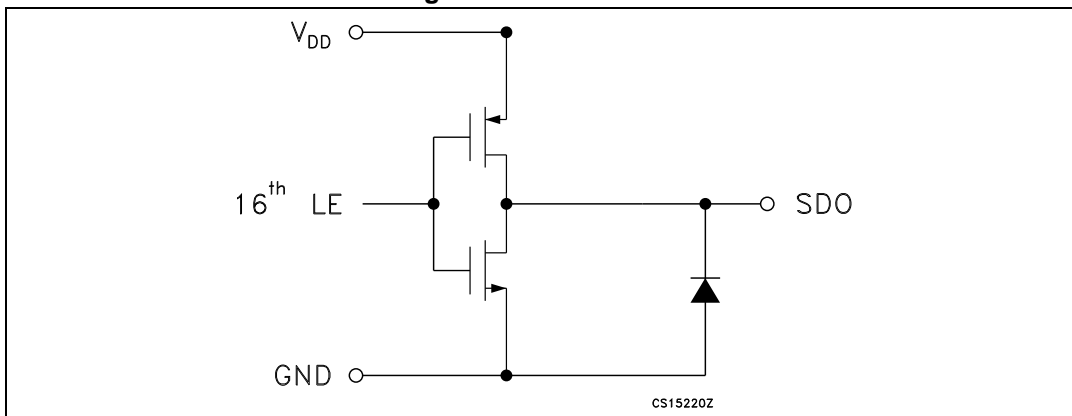
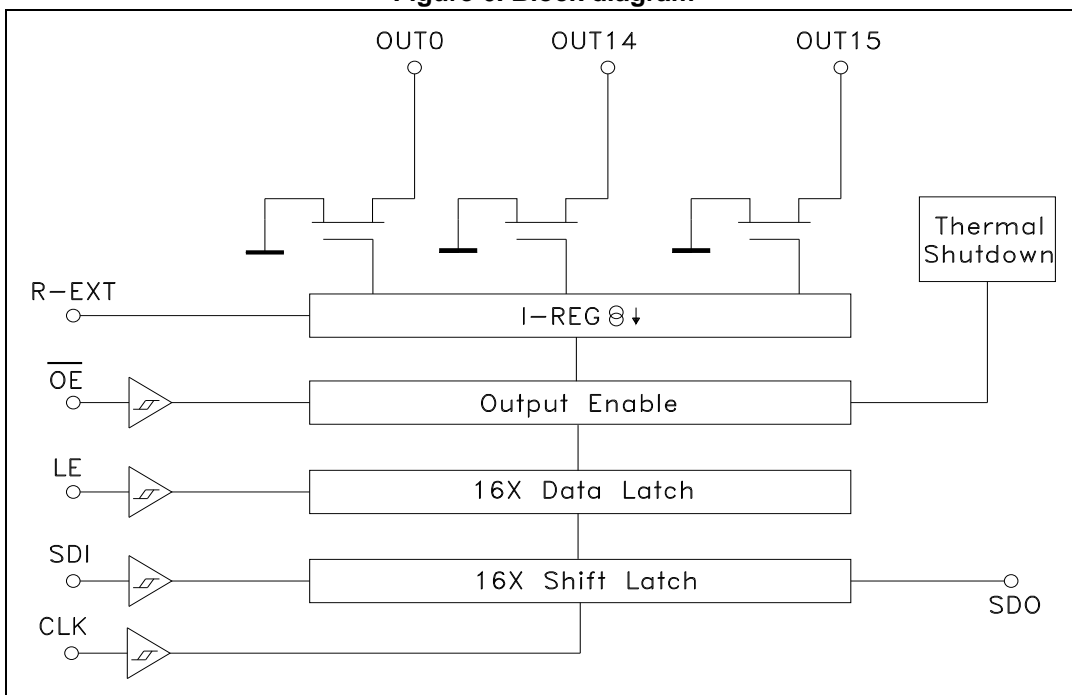

Figure 6. Block diagram



## 5 Timing diagrams

Table 9. Truth table

CLOCK	LE	$\overline{OE}$	Serial-IN	OUT0 ..... OUT7 ..... OUT15	SDO
┌	H	L	Dn	Dn ..... Dn - 7 ..... Dn -15	Dn - 15
┌	L	L	Dn + 1	No change	Dn - 14
┌	H	L	Dn + 2	Dn + 2 ..... Dn - 5 ..... Dn -13	Dn - 13
└	X	L	Dn + 3	Dn + 2 ..... Dn - 5 ..... Dn -13	Dn - 13
└	X	H	Dn + 3	OFF	Dn - 13

Note:  $OUTn = ON$  when  $Dn = H$   $OUTn = OFF$  when  $Dn = L$

Figure 7. Timing diagram

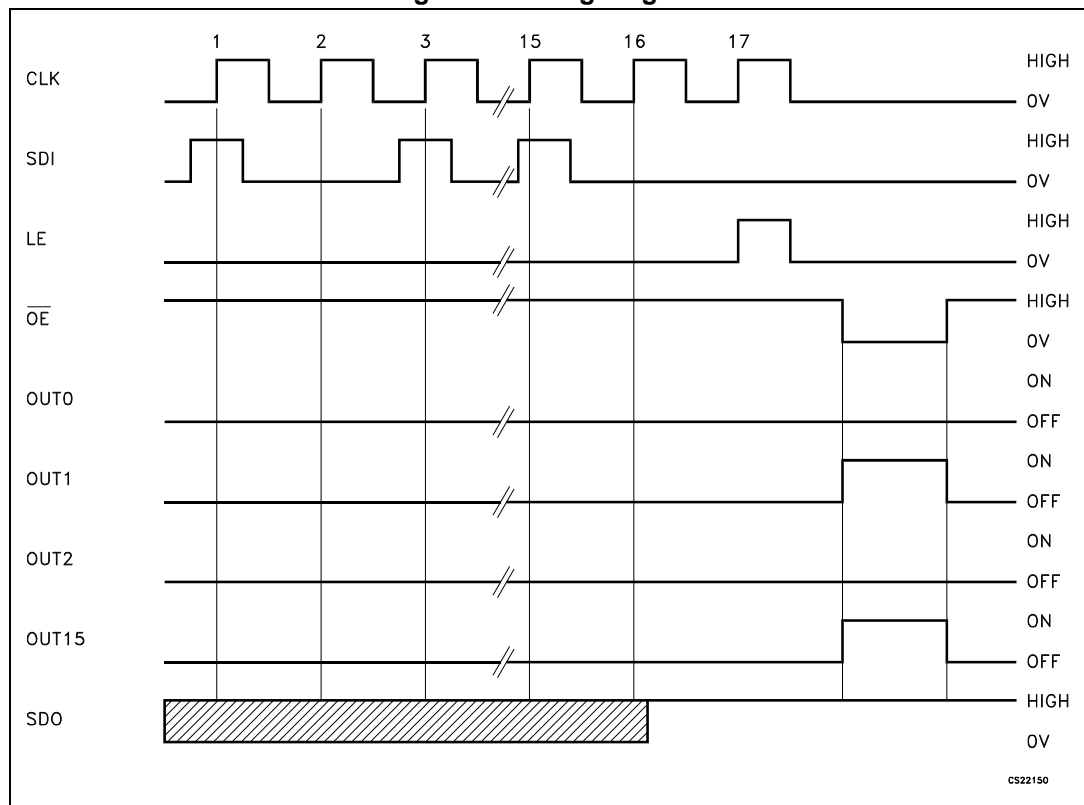

Note: The latches circuit holds data when the LE terminal is Low.

- 1 When LE terminal is at high level, latch circuit does not hold the data it passes from the input to the output.
- 2 When  $\overline{OE}$  terminal is at low level, output terminals OUT0 to OUT15 respond to the data, either ON or OFF.
- 3 When  $\overline{OE}$  terminal is at high level, it switches off all the data on the output terminal.

Figure 8. Clock, serial-in, serial-out

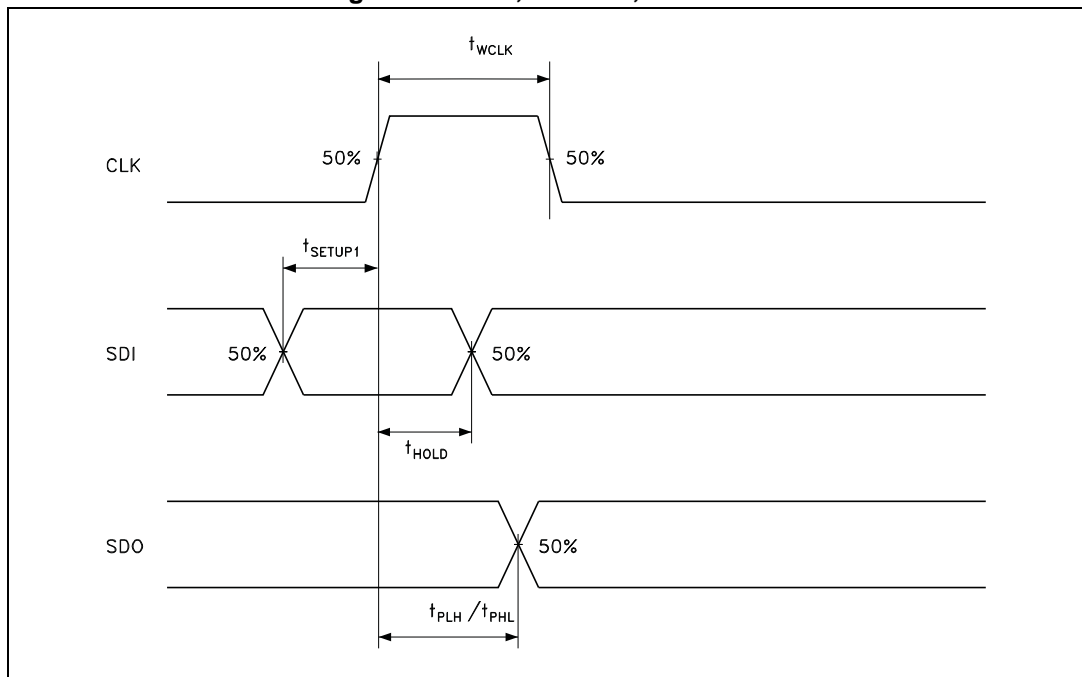

Figure 9. Clock, serial-in, latch, enable, outputs

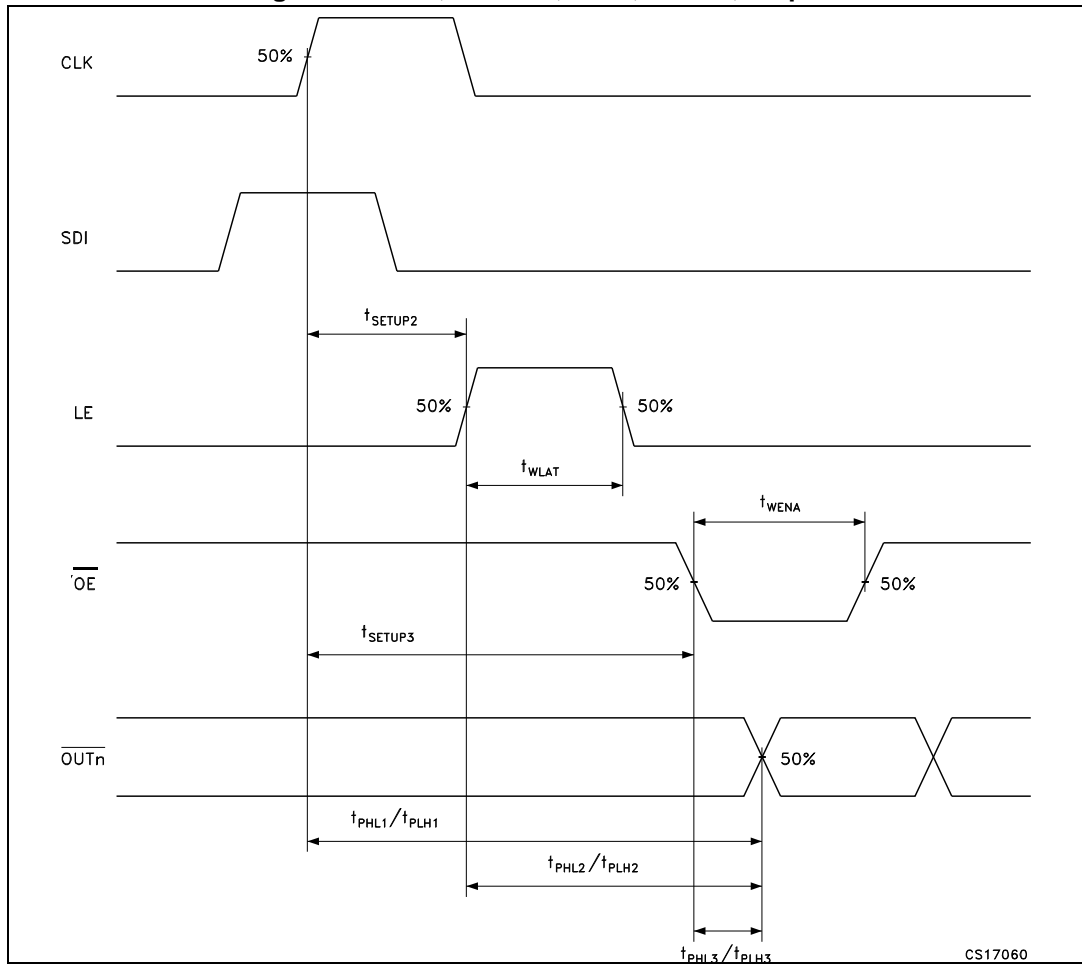
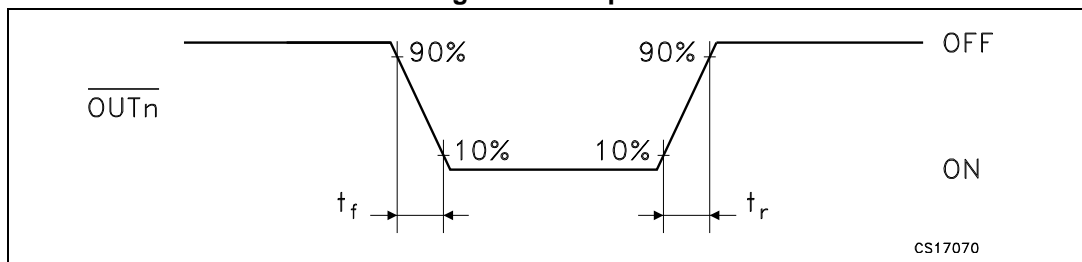

Figure 10. Outputs



## 6 Typical characteristics

Figure 11. Output current- $R_{EXT}$  resistor

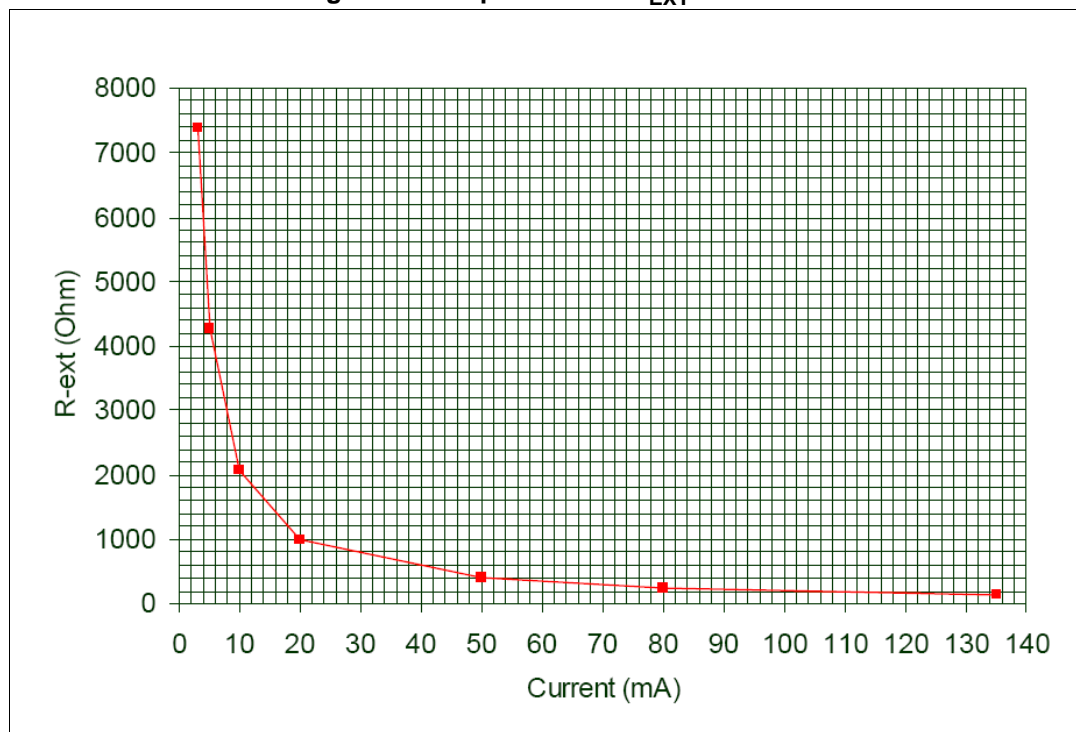

Table 10. Output current- $R_{EXT}$  resistor

$R_{ext}$ ( $\Omega$ )	Output current (mA)
7370	3
4270	5
2056	10
1006	20
382	50
251	80
200	100

Figure 12. Output current vs  $\pm \Delta I_{OL}(\%)$   $T_A = 25^\circ C$

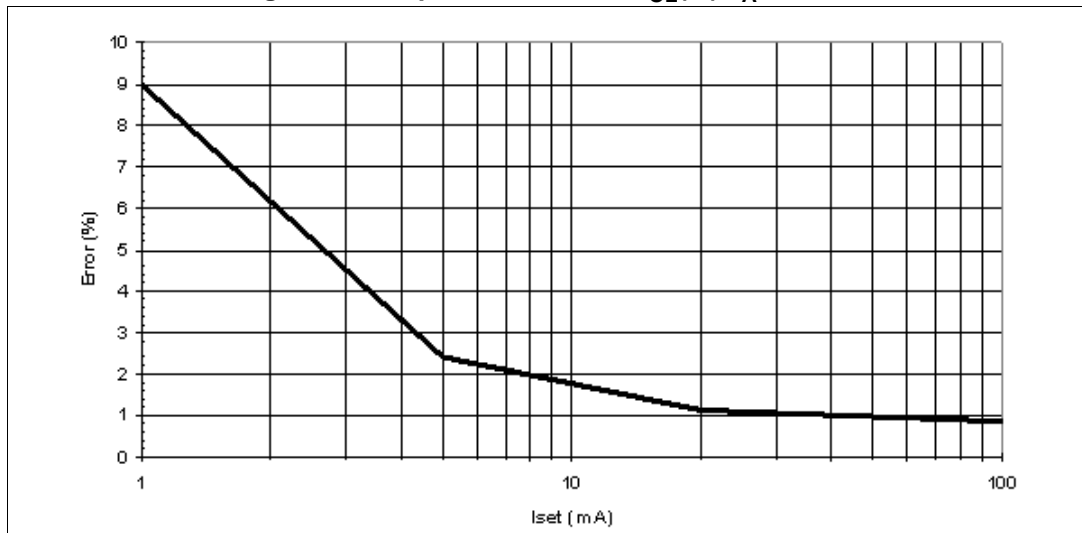
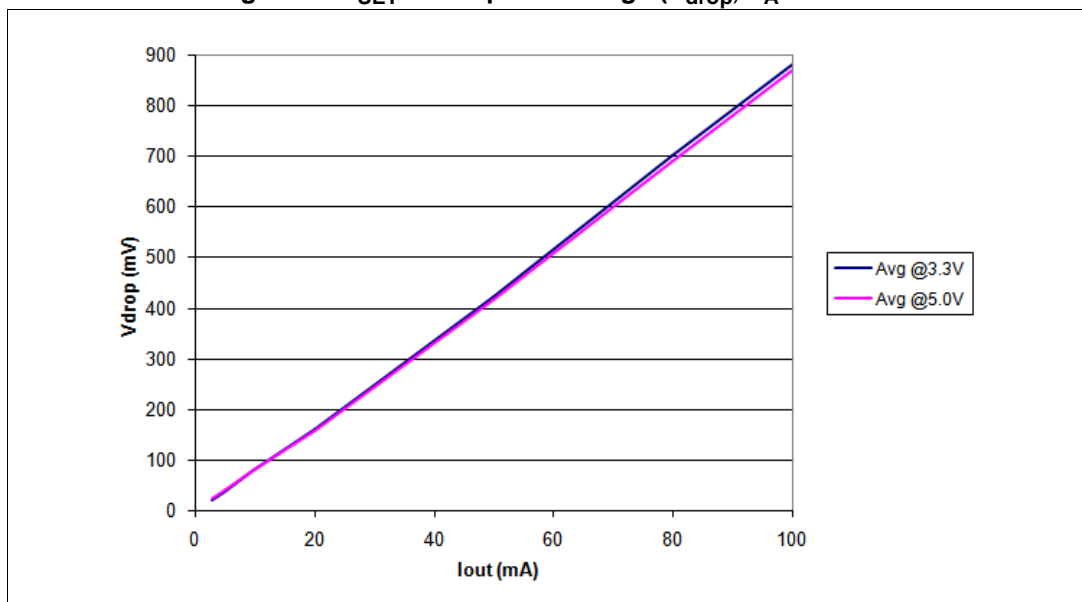
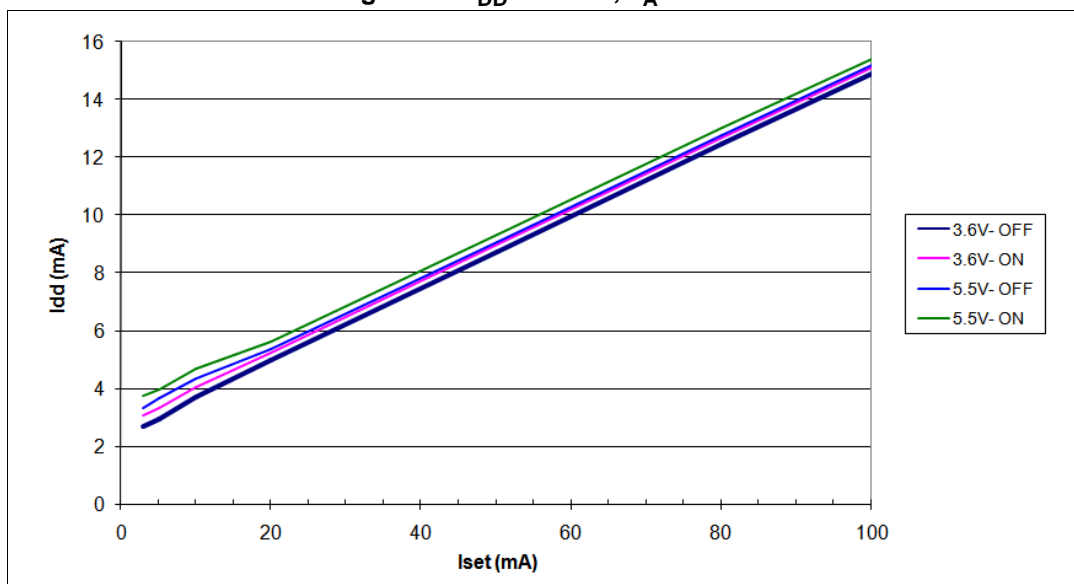

Figure 13.  $I_{SET}$  vs drop out voltage ( $V_{drop}$ )  $T_A = 25^\circ C$



Iout (mA)	Avg @3.3 V	Avg @5.0 V
3	20	22
5	37	40
10	79	79
20	160	158
50	422	415
80	700	690
100	880	870

Figure 14.  $I_{DD}$  ON/OFF,  $T_A = 25\text{ }^\circ\text{C}$





# 7 Test circuit

Figure 15. DC characteristic

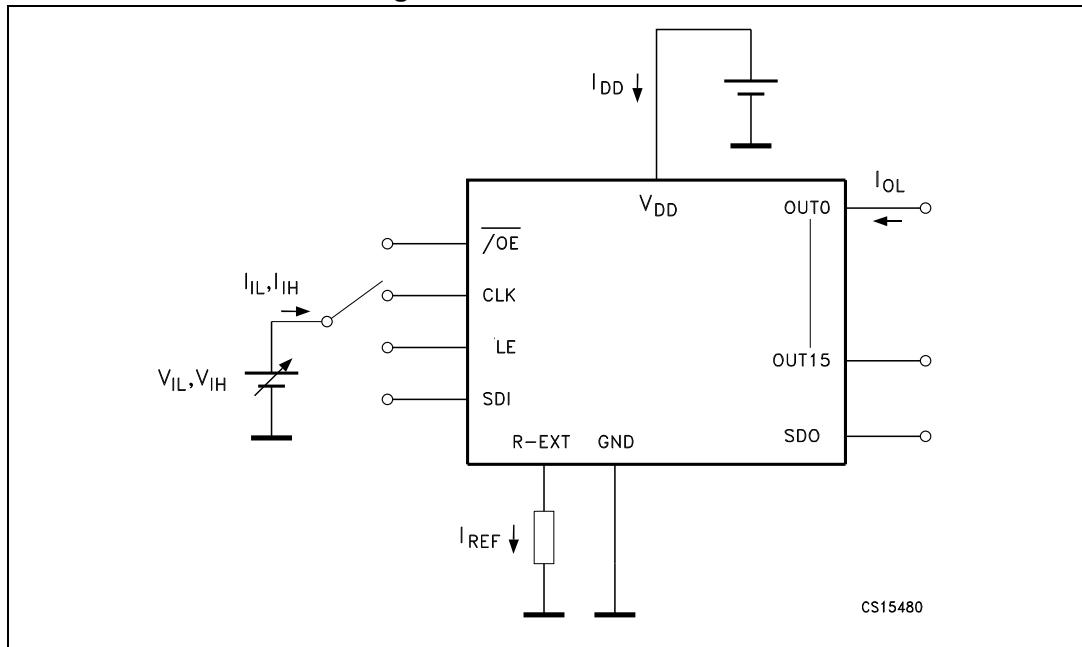

Figure 16. AC characteristic

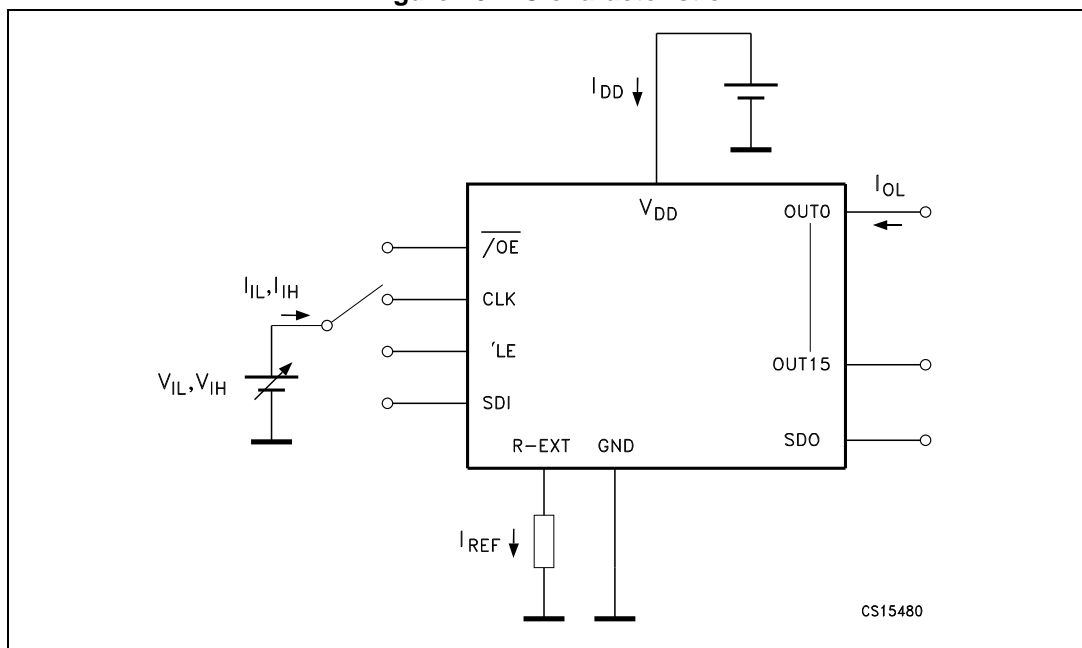
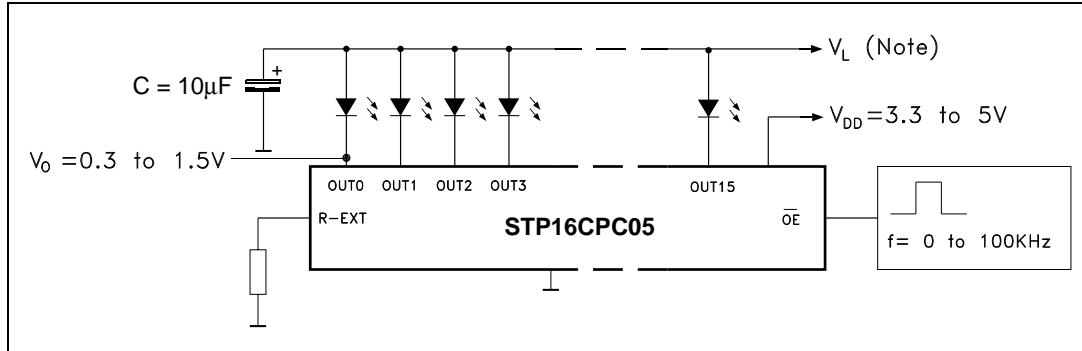

Figure 17. Typical application schematic



Note:  $V_L$  will be determined by the  $V_F$  of the LEDs

Test condition: Temp. = 25 °C,  $V_{DD}$  = 3.3 V,  $C_L$  = 10 pF, Freq. = 1 MHz,

Figure 18. Turn ON output current setup

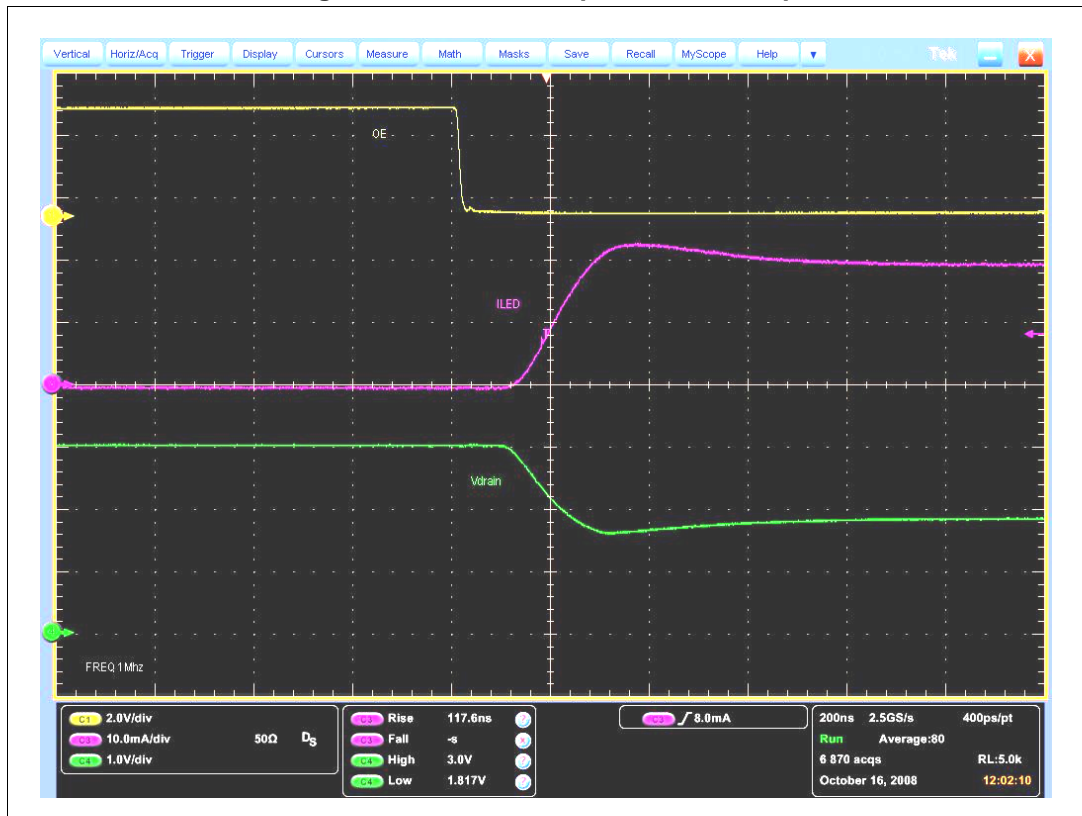
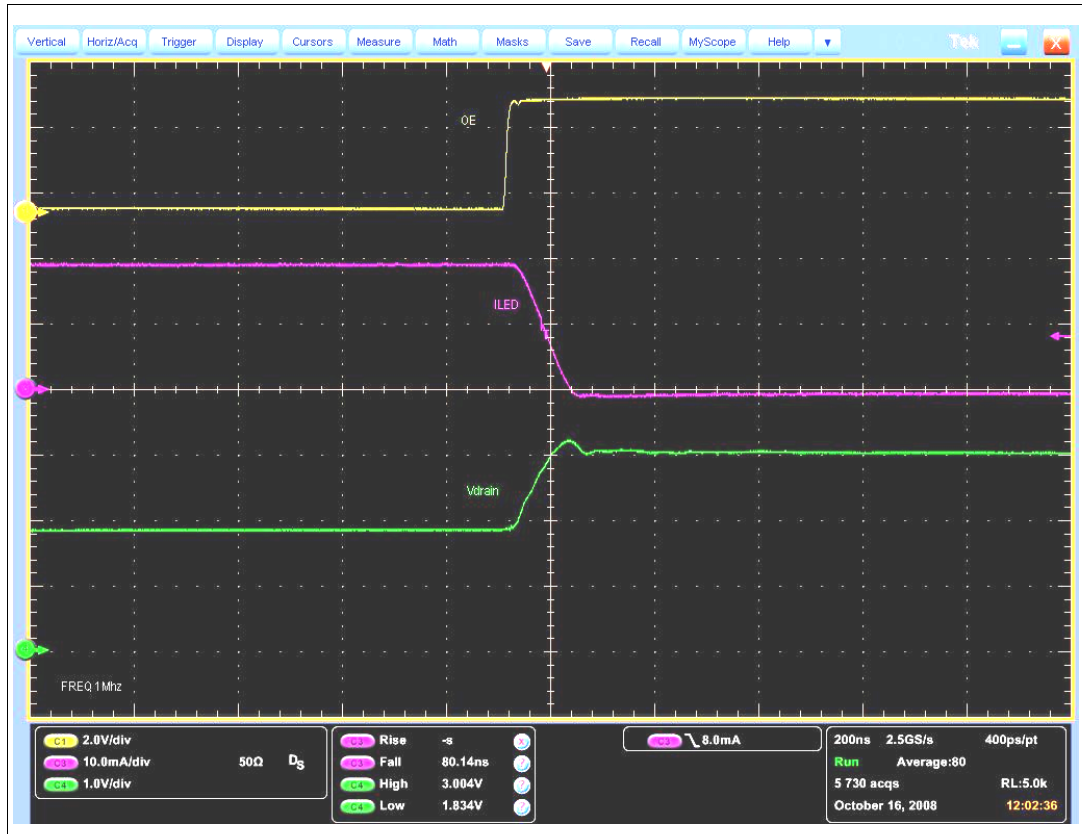

Figure 19. Turn OFF output current setup



## 8 Package mechanical data

In order to meet environmental requirements, ST offers these devices in different grades of ECOPACK® packages, depending on their level of environmental compliance. ECOPACK® specifications, grade definitions and product status are available at: [www.st.com](http://www.st.com). ECOPACK® is an ST trademark.

Figure 20. QSOP-24 package dimensions

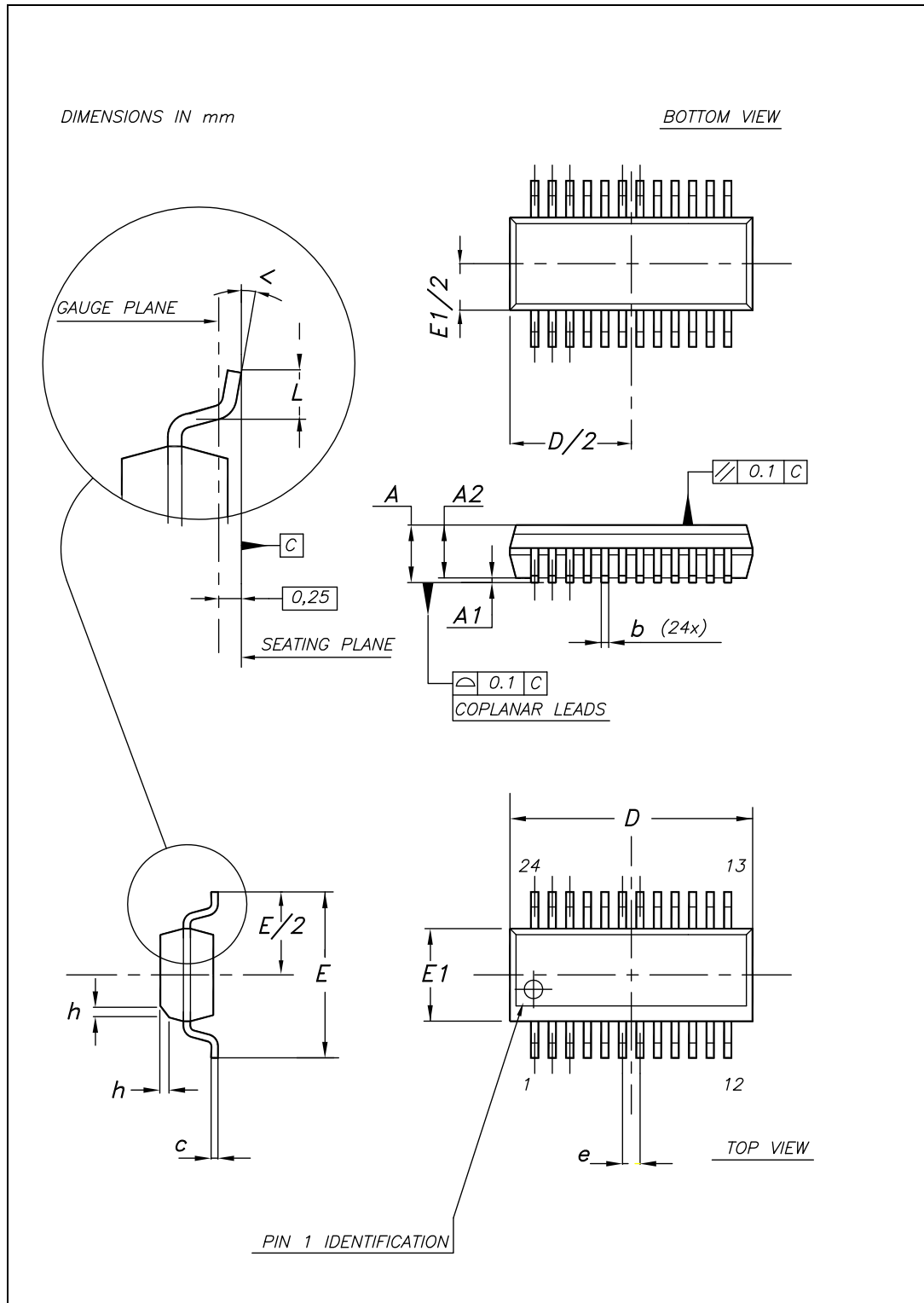

Table 11. QSOP-24 mechanical data

Dim.	mm.		
	Min	Typ	Max
A	1.54	1.62	1.73
A1	0.1	0.15	0.25
A2		1.47	
b	0.31	0.2	
c	0.254	0.17	
D	8.56	8.66	8.76
E	5.8	6	6.2
E1	3.8	3.91	4.01
e		0.635	
L	0.4	0.635	0.89
h	0.25	0.33	0.41
<	8°	0°	

Figure 21. TSSOP24 package dimensions

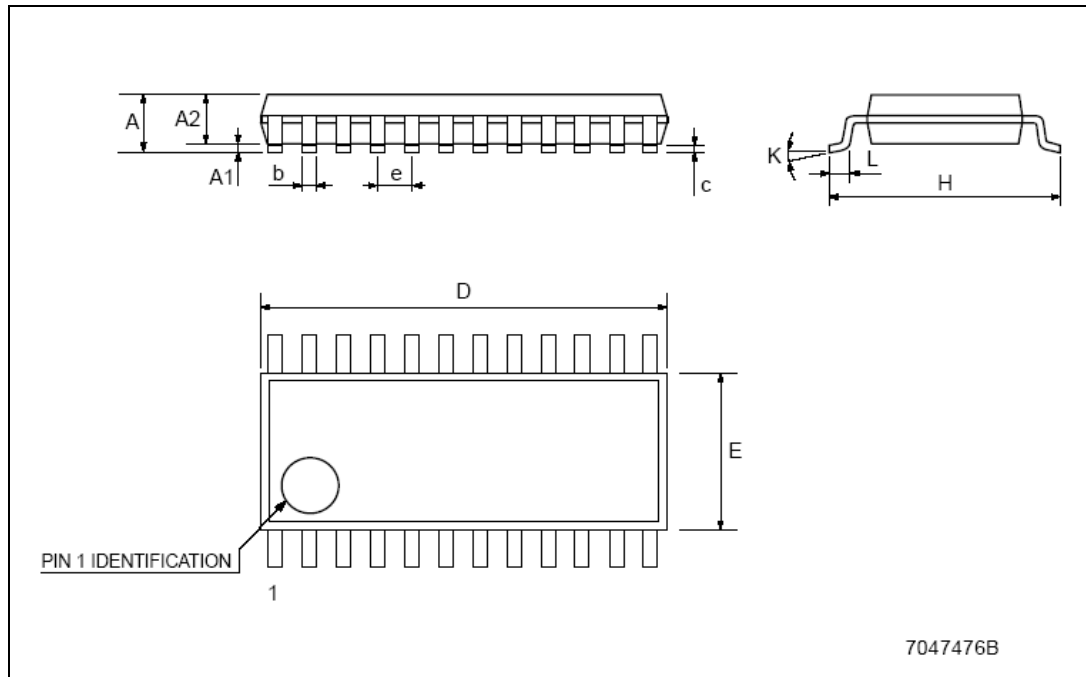

Table 12. TSSOP24 mechanical data

Dim.	mm		
	Min.	Typ.	Max.
A			1.1
A1	0.05		0.15
A2		0.9	
b	0.19		0.30
c	0.09		0.20
D	7.7		7.9
E	4.3		4.5
e		0.65 BSC	
H	6.25		6.5
K	0°		8°
L	0.50		0.70

Figure 22. SO-24 package dimensions

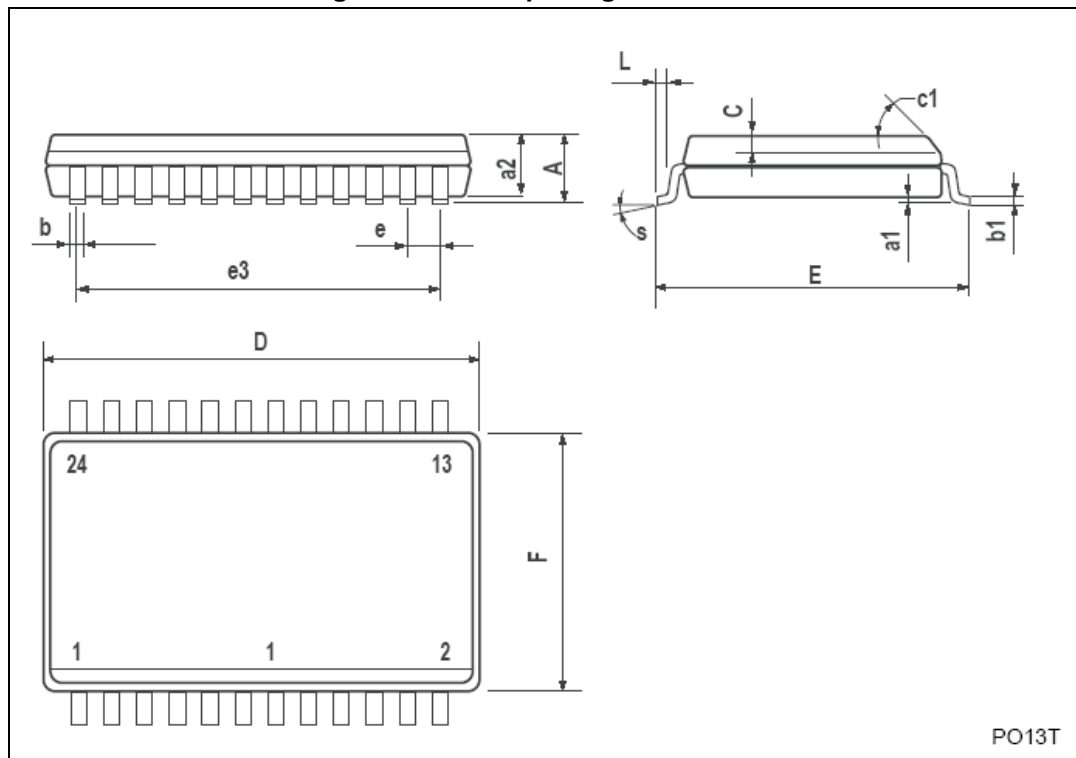

Table 13. SO-24 mechanical data

Dim.	mm.		
	Min	Typ	Max
A			2.65
a1	0.1		0.2
a2			2.45
b	0.35		0.49
b1	0.23		0.32
C		0.5	
c1	45°(typ.)		
D	15.20		15.60
E	10.00		10.65
e		1.27	
e3		13.97	
F	7.40		7.60
L	0.50		1.27
S	°(max.) 8		



Figure 23. TSSOP24 exposed pad dimensions

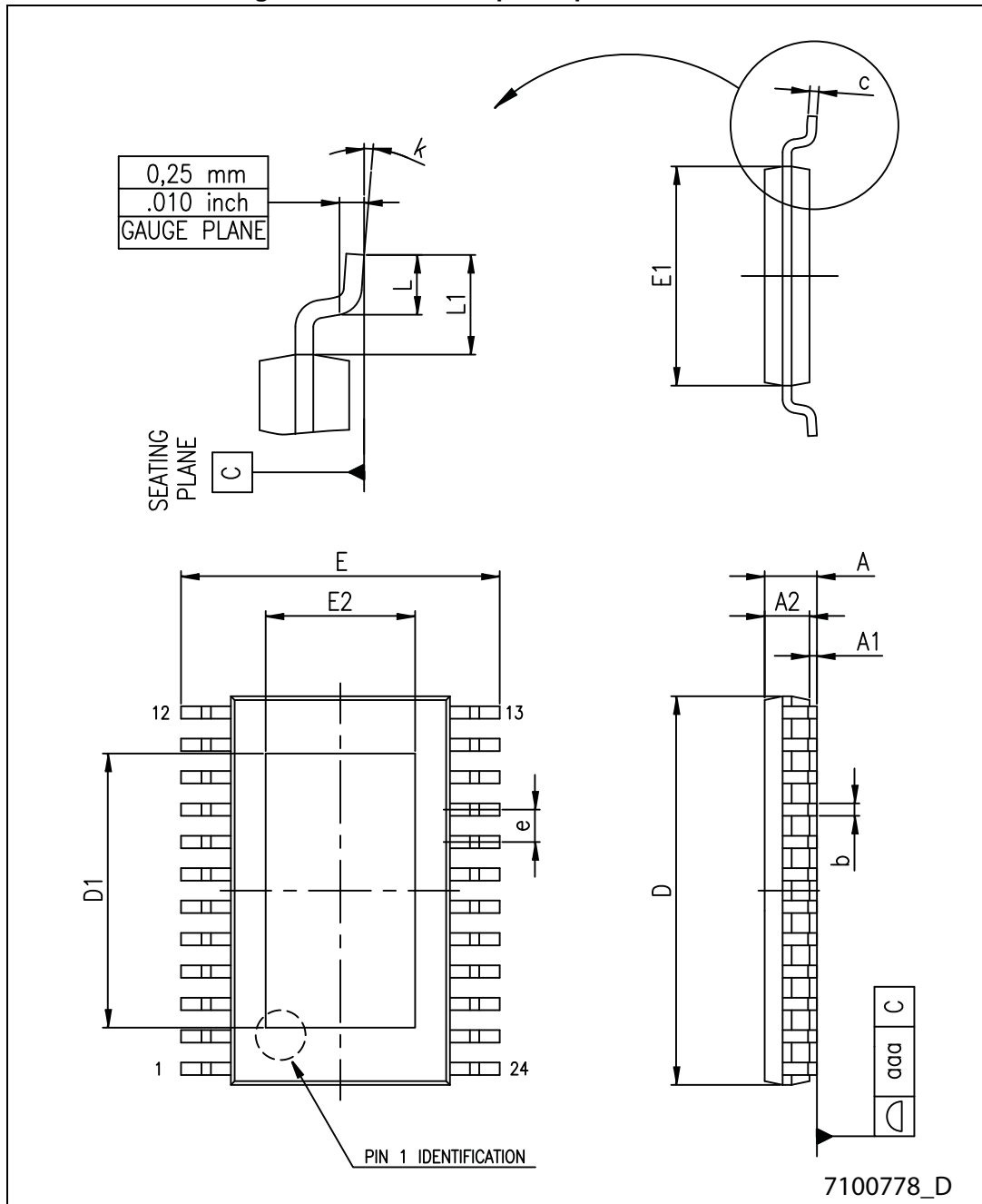

Table 14. TSSOP24 exposed pad mechanical data

Dim.	mm		
	Min.	Typ.	Max.
A			1.20
A1			0.15
A2	0.80	1.00	1.05
b	0.19		0.30
c	0.09		0.20
D	7.70	7.80	7.90
D1	4.80	5.00	5.2
E	6.20	6.40	6.60
E1	4.30	4.40	4.50
E2	3.00	3.20	3.40
e		0.65	
L	0.45	0.60	0.75
L1		1.00	
k	0		8
aaa			0.10

## 9 Packaging mechanical data

Figure 24. TSSOP24, TSSOP24 exposed pad and SO-24 reel dimensions

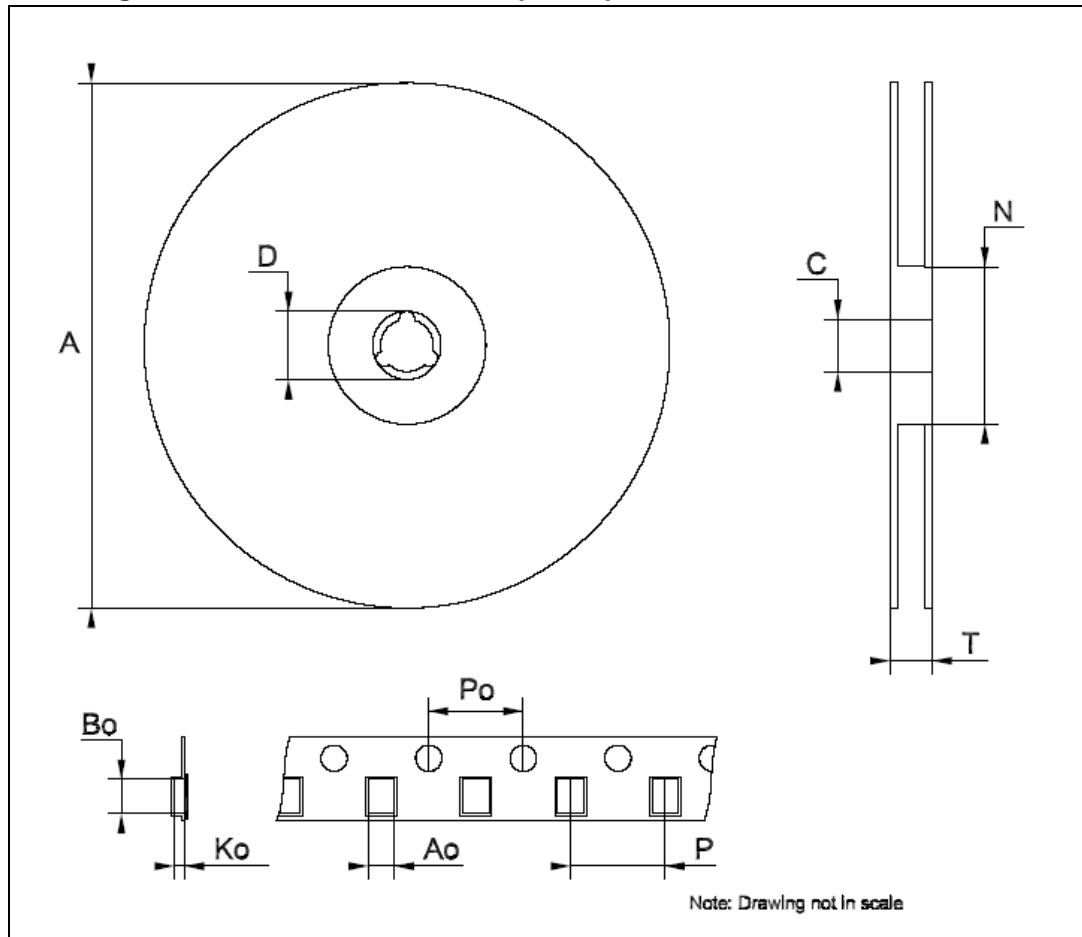

Table 15. TSSOP24 and TSSOP24 exposed pad tape and reel mechanical data

Dim.	mm		
	Min.	Typ.	Max.
A		-	330
C	12.8	-	13.2
D	20.2	-	
N	60	-	
T		-	22.4
Ao	6.8	-	7
Bo	8.2	-	8.4
Ko	1.7	-	1.9
Po	3.9	-	4.1
P	11.9	-	12.1

Table 16. SO-24 tape and reel mechanical data

Dim.	mm.		
	Min	Typ	Max
A		-	330
C	12.8	-	13.2
D	20.2	-	
N	60	-	
T		-	30.4
Ao	10.8	-	11.0
Bo	15.7	-	15.9
Ko	2.9	-	3.1
Po	3.9	-	4.1
P	11.9	-	12.1

## 10 Revision history

Table 17. Document revision history

Date	Revision	Changes
30-Jan-2009	1	First release
12-May-2009	2	Updated <a href="#">Table 6 on page 6</a>
29-Oct-2009	3	Updated <a href="#">Note: on page 3</a>
16-Jun-2014	4	Updated <a href="#">Section 8: Package mechanical data</a> . Added <a href="#">Section 9: Packaging mechanical data</a> . Minor text changes.

**Please Read Carefully:**

Information in this document is provided solely in connection with ST products. STMicroelectronics NV and its subsidiaries ("ST") reserve the right to make changes, corrections, modifications or improvements, to this document, and the products and services described herein at any time, without notice.

All ST products are sold pursuant to ST's terms and conditions of sale.

Purchasers are solely responsible for the choice, selection and use of the ST products and services described herein, and ST assumes no liability whatsoever relating to the choice, selection or use of the ST products and services described herein.

No license, express or implied, by estoppel or otherwise, to any intellectual property rights is granted under this document. If any part of this document refers to any third party products or services it shall not be deemed a license grant by ST for the use of such third party products or services, or any intellectual property contained therein or considered as a warranty covering the use in any manner whatsoever of such third party products or services or any intellectual property contained therein.

**UNLESS OTHERWISE SET FORTH IN ST'S TERMS AND CONDITIONS OF SALE ST DISCLAIMS ANY EXPRESS OR IMPLIED WARRANTY WITH RESPECT TO THE USE AND/OR SALE OF ST PRODUCTS INCLUDING WITHOUT LIMITATION IMPLIED WARRANTIES OF MERCHANTABILITY, FITNESS FOR A PARTICULAR PURPOSE (AND THEIR EQUIVALENTS UNDER THE LAWS OF ANY JURISDICTION), OR INFRINGEMENT OF ANY PATENT, COPYRIGHT OR OTHER INTELLECTUAL PROPERTY RIGHT.**

**ST PRODUCTS ARE NOT DESIGNED OR AUTHORIZED FOR USE IN: (A) SAFETY CRITICAL APPLICATIONS SUCH AS LIFE SUPPORTING, ACTIVE IMPLANTED DEVICES OR SYSTEMS WITH PRODUCT FUNCTIONAL SAFETY REQUIREMENTS; (B) AERONAUTIC APPLICATIONS; (C) AUTOMOTIVE APPLICATIONS OR ENVIRONMENTS, AND/OR (D) AEROSPACE APPLICATIONS OR ENVIRONMENTS. WHERE ST PRODUCTS ARE NOT DESIGNED FOR SUCH USE, THE PURCHASER SHALL USE PRODUCTS AT PURCHASER'S SOLE RISK, EVEN IF ST HAS BEEN INFORMED IN WRITING OF SUCH USAGE, UNLESS A PRODUCT IS EXPRESSLY DESIGNATED BY ST AS BEING INTENDED FOR "AUTOMOTIVE, AUTOMOTIVE SAFETY OR MEDICAL" INDUSTRY DOMAINS ACCORDING TO ST PRODUCT DESIGN SPECIFICATIONS. PRODUCTS FORMALLY ESCC, QML OR JAN QUALIFIED ARE DEEMED SUITABLE FOR USE IN AEROSPACE BY THE CORRESPONDING GOVERNMENTAL AGENCY.**

Resale of ST products with provisions different from the statements and/or technical features set forth in this document shall immediately void any warranty granted by ST for the ST product or service described herein and shall not create or extend in any manner whatsoever, any liability of ST.

ST and the ST logo are trademarks or registered trademarks of ST in various countries.

Information in this document supersedes and replaces all information previously supplied.

The ST logo is a registered trademark of STMicroelectronics. All other names are the property of their respective owners.

© 2014 STMicroelectronics - All rights reserved

STMicroelectronics group of companies

Australia - Belgium - Brazil - Canada - China - Czech Republic - Finland - France - Germany - Hong Kong - India - Israel - Italy - Japan - Malaysia - Malta - Morocco - Philippines - Singapore - Spain - Sweden - Switzerland - United Kingdom - United States of America

[www.st.com](http://www.st.com)