

3-Port JTAG Gateway

Description

The AS91L1003U is a one to 3-port JTAG gateway. It partitions a single JTAG chain into three separate chains. These separate chains can be optionally configured to operate as a single chain.

The AS91L1003U device is used to provide enhanced capabilities to the standard IEEE1149.1. It enables the IEEE1149.1 interface to be used in a true Multi-Drop environment without any additional signals. This Multi-Drop capability enables the standard IEEE1149.1 interface to be used not just for stand alone Printed Circuit Board (PCB) testing, but complete system back testing including all PCBs within a system back plane environment.

The AS91L1003U provides the capability of partitioning the PCB into multiple smaller IEEE1149.1 scan chains totally under software

control. Partitioning the IEEE1149.1 chains on the PCB has several benefits, which include easier fault diagnostics capabilities, as a fault on one of the IEEE1149.1 Local Scan Ports (LSPs) does not render the PCB un-testable, faster flash programming on the PCB's and removal of IEEE1149.1 signal loading issues.

All of the protocols required for addressing the AS91L1003U device via the Multi-Drop capability and the protocols for configuring which of the three IEEE1149.1 LSPs of the AS91L1003U are to be used, is handled via the 3rd party ATPG tools from vendors like Asset-Intertech and JTAG Technologies. In a Multi-Drop environment, it is also possible to perform interconnect tests between multiple PCBs within the system thus extending the interconnect tests to the back plane itself.

Key Features

- Device Multi-Drop addressable via the IEEE 1149.1 protocol
- Support for 3 local scan chains addressable via the IEEE 1149.1 interface
- Support for Pass-Through™
- Support for the IEEE 1149.1 USERCODE instruction
- Support for Status instruction enabling non-intrusive monitoring of the system card
- Local Scan Port (LSP) enable signal provides the ability to use non IEEE 1149.1 compliant devices that require JTAG enable signal
- Provides the ability to initiate Self-Test on a remote PCB via a standard IEEE 1149.1 command
- Support for JTAG Technologies AutoWR™ feature
- Pinout and feature set compatible (complete second source) with the Firecron JTS03U device
- Available in a 100-pin LQFP or a 100-pin FPBGA lead free package

Device Block Diagram

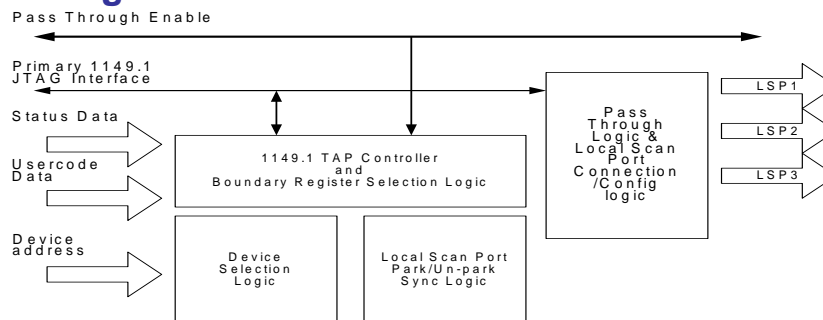

Figure 1 - AS91L1003U Device Block Diagram



AS91L1003U Gateway Functional Description

The basic structure of the AS91L1003U device is shown in Figure 1. The core of the device is the 16-state IEEE1149.1 TAP controller state machine. All accesses to the internal registers of the AS91L1003U device are controlled via this state machine during normal operation as per the IEEE1149.1 standard. The address selection logic enables the AS91L1003U to operate in a Multi-Drop environment within system backplane.

The address selection logic compares the scanned address to the slot address value presented on the I/O of the AS91L1003U device. The LSP park/unpark logic provides control through instructions scanned in under the IEEE1149.1 protocol, to select which LSP will be placed into the active scan chain. The pass-through and LSP connection logic selects the signal paths for the LSP IEEE1149.1 signals. The device also supports a Pass-Through mode which

enables the primary IEEE1149.1 signals to be routed to any of the LSPs. This signal routing is selectable via I/O pins on the AS91L0003U device.

The AS91L1003U operation is controlled via core blocks through three closely coupled state machines. Figure-2 shows the device selection state machine. The AS91L1003U will perform an address compare on the slot address presented at its I/O and the value scanned in via the IEEE1149.1. If the value matches, then the AS91L1003U becomes selected and is ready for normal access via IEEE1149.1 commands. If the address does not match then the device will proceed to the unselected mode, where it will remain until the AS91L1003U is issued a GOTOWAIT instruction or a reset occurs via either TRST or the LSP_RESET pin.

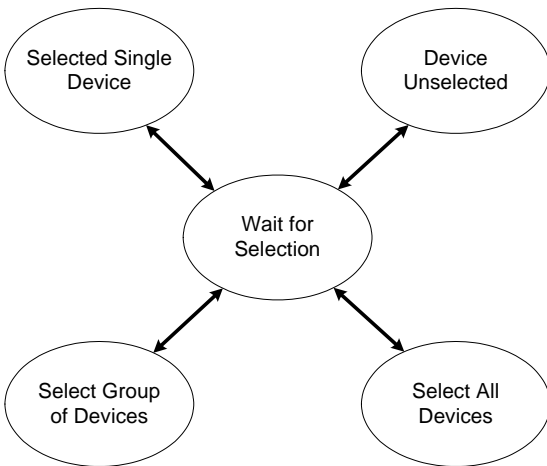

Figure 2 - AS91L1003U Selection Logic State machine

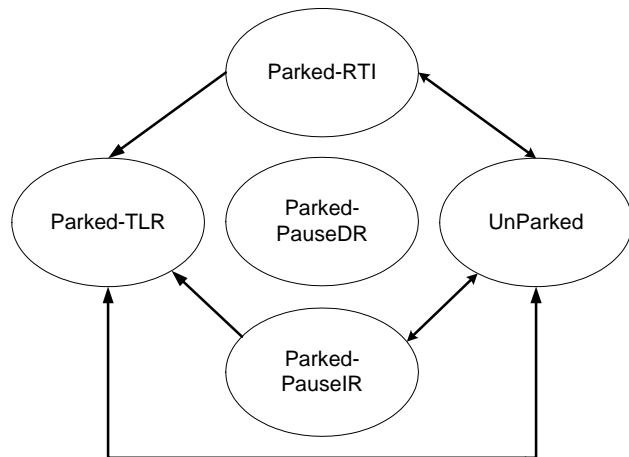

Figure 3 - The LSP Park/Unpark State Machine

The LSP Park/Unpark state machine controls the insertion of the LSPs into the current active scan chain. The ability to park the LSP in certain IEEE1149.1 states, enable the AS91L1003U to perform several functions including backplane interconnect testing and IC BIST.



AS91L1003U Detailed Mode of Operation

Addressing the AS91L1003U device

After a Test-Logic-Reset or power-up, the AS91L1003U device will be in its Wait-for-Selection state with its TDO pin tri-stated, thus avoiding contention in a Multi-Drop environment. The AS91L1003U device will respond to a device-select sequence for a particular address that is auto generated by third party test tools with respect to the address that is pre-loaded on its S(5..0) pins. Once this sequence has been completed, the AS91L1003U device will respond to normal IEEE 1149.1 instructions. Note that addresses 60-63 have been reserved and the AS91L1003U device will not respond if the user selects these addresses.

To be selected, the AS91L1003U device should be in the Wait-for-Selection mode which can be entered into by issuing an asynchronous reset (through the deassertion of TRST) or by issuing synchronous reset (through the assertion of TMS for five cycles of TCK). After the device has been selected, it can be issued a GOTOWAIT instruction or a reset of the AS91L1003U device.

The internal IEEE1149.1 state machine of the AS91L1003U device is taken to the Shift-IR phase and the required Device-ID is shifted into the Instruction register. As the IEEE1149.1 state machine passes through the Update-IR phase, the address is matched to the value on the S(5-0) pins on the AS91L1003U device; if the values match then the AS91L1003U device is selected and is ready to receive any normal IEEE1149.1 command.

S(5-0) value	IR (7 – 0) value
< 3A hex or 60 decimal	XXVVVVVV

Table 1 - AS91L1003U Device Selection Table



Table 2 - AS91L1003U Multi Cast Group Selection Table

Selection Mode	Binary Address	Function
Single Address Mode	XX000000 to XX111010	Single AS91L1003U selected the TDO of the device will be active
Broad-Cast Mode	XX111011	All accessible AS91L1003U devices are selected for operation. TDO on all devices will be in HighZ
Multi-Cast Group 0	XX111100	Access all AS91L1003U device that have been placed in GRP0 by their MCGR contents
Multi-Cast Group 1	XX111101	Access all AS91L1003U device that have been placed in GRP1 by their MCGR contents
Multi-Cast Group 2	XX111110	Access all AS91L1003U device that have been placed in GRP2 by their MCGR contents
Multi-Cast Group 3	XX111111	Access all AS91L1003U device that have been placed in GRP3 by their MCGR contents

Table 3 - AS91L1003U Device Register Description

Register Name	Description
Instruction Register	AS91L1003U device addressing and instruction-decode IEEE Std. 1149.1 required register
Boundary-Scan Register	IEEE Std. 1149.1 required register
Bypass Register	IEEE Std. 1149.1 required register
Device Identification Register	IEEE Std. 1149.1 optional register
User Code Register	IEEE Std. 1149.1 optional register
Status Register	AS91L1003U device non intrusive 8-bit register pre load able from the I/O pins
Self Test Register	AS91L1003U device specific single bit register for initiating self testing on a PCB
Mode Register	AS91L1003U device local-port configuration and control bits
Auto Write Register	AS91L1003U device Auto Write feature enable register
Local Scan Port Async Reset Register	AS91L1003U device Async reset register for the LSPs



Instructions	Hex Op-Code	Binary Op-Code	Data Register
BYPASS	FF	11111111	Bypass Register
EXTEST	00	00000000	Boundary-Scan Register
SAMPLE/PRELOAD	81	10000001	Boundary-Scan Register
IDCODE	AA	10101010	Device Identification Register
UNPARK	E7	11100111	Device Identification Register
PARKTLR	C5	11000101	Device Identification Register
PARKRTI	84	10000100	Device Identification Register
PARKPAUSE	C6	11000110	Device Identification Register
GOTOWAIT*	C3	11000011	Device Identification Register
MODESELECT	8E	10001110	Mode Register
MCGRSELECT	03	00000011	Multi-Cast Group Register.
SOFTRESET	88	10001000	Device Identification Register
USERCODE	97	10010111	User Programmable 32 Bit Identification Register
AUTOWR	98	10011000	Auto Write Feature Enable Register
STEST_PCB	99	10011001	Single bit low pulse used to initiate function on PCB (SELF_TEST pin)
STATUS_BYTE	9A	10011010	User programmable status byte (USER_STATUS_DATA pins)
LSP_ASYNC_RESET	9B	10011011	Toggles LSP TRST while maintaining the AS91L1003U in the selected state.
Other Undefined	TBD	TBD	Device Identification Register

Table 4 - AS91L1003U Device Instruction Register OpCodes



Note: All instructions act on a single selected AS91L1003U device only.

*** This instruction causes the AS91L1003U to become unselected and revert to the Wait-for-Selection state.**



AS91L1003U device Register descriptions

Bypass Register

It is a mandatory single bit register that can be connected between PRIM_TDI and PRIM_TDO of the AS91L1003U device.

Multi-Cast Group Register

This 2-bit data register enables the host system to place the AS91L1003U into one of four distinct addressable groups.

MCGR Register Bits [1..0]	Binary Selection Address	MCGR GROUP
00	XX111100	GRP0
01	XX111101	GRP1
10	XX111110	GRP2
11	XX111111	GRP3

Table 5 - Multicast Group Register Mapping



Note: The MCGR is reset to 00 upon receiving TRST or the entering of the Test-Logic-Reset state.

IDCODE Register

It is an optional 32-bit register that can be connected between PRIM_TDI and PRIM_TDO of the AS91L1003U device. The contents of the IDCODE register will be loaded with the following data when the AS91L1003U enters Test-Logic-Reset or passes through Capture-IR:

"00000000000000001000001101101111"

Bits 0 to 11 indicate ALSC Jedec ID value of: "001101101111"

Bits 12 to 27 indicate the part number of the device: "0000000000010000"

Bits 28 to 31 indicate the revision of the device: "0000"

USERCODE Register

The USERCODE is a 32-bit register that can be addressed via standard IEEE1149.1 commands, which are automatically generated by third party test tools. The end user has the ability to program the binary value that will be transmitted back to the host via the USERCODE command; by setting the binary pattern on the USERCODE pins on the AS91L1003U device.



* The AS91L1003U is a complete second source and pin for pin replacement of the Firecron JTS03U device.



STATUS_BYTE Register

The STATUS_BYTE register on the AS91L1003U device provides a means to sense the value on the USER_STATUS_DATA pins on the AS91L1003U device. This is an 8-bit field where the user can non-intrusively monitor signals on the printed circuit card via the IEEE1149.1 interface. The data in the register is loaded each time the state machine passes through the Capture-DR phase.

 **Note: Value is positive logic.**

SELF_TEST Register

The AS91L1003U device supports a single output pin that can be controlled via the IEEE1149.1 interface. When the instruction is loaded into the AS91L1003U instruction register, a single bit data register is connected which is set to zero when the TAP state machine enters Capture-DR. This will cause the SELF_TEST pin to pulse low for one cycle of TCK, during the Update-DR phase. This low going pulse can be used to initiate self-tests on PCB's in a rack via the JTAG interface.

LSP_ASYNC_RST Register

The AS91L1003U device supports async reset tests on the devices connected to the LSPs. The standard method of performing these tests by utilizing the PRIM_TRST pin cannot be used as it will cause the AS91L1003U to deselect and all its internal registers to be reset. In order to enable async reset tests on the LSP, the test tool should instruct the device to toggle the local scan port reset pins while maintaining the set up information in the AS91L1003U. When the instruction is loaded into the AS91L1003U instruction register, a single bit data register is connected which is always set to zero when the TAP state machine enters Capture-DR. This will cause the LSP TRST pins to pulse low for one TCK cycle, during the Update-DR phase.

AUTOWR Register

This is a 3-bit register that controls the pass-through of the JTAG Technologies AutoWR™ signal to any Local Scan Port. The register is reset to all zeros when entering the Test-Logic-Reset state.

AutoWr Register (Bit 2 – Bit 0)	LSP 3 AutoWr Signal	LSP 2 AutoWr Signal	LSP 1 AutoWr Signal
000	High Z	High Z	High Z
001	High Z	High Z	Active
011	High Z	Active	Active
100	Active	High Z	High Z
101	Active	High Z	Active
110	Active	Active	High Z
111	Active	Active	Active

Table 6 - AUTOWR Register Mapping



MODE_SELECT Register

The Mode_Select register allows the Local Scan Port of the AS91L1003U to be connected in various different configurations. A LSP is selected for connection within the scan chain by the contents of the Mode_Select register.

If the Local Scan Port is not parked in a stable state, i.e.: Pause-DR, Pause-IR, Run-Test-Idle or Test-Logic-Reset, it will be connected into the active scan chain. If all LSPs are parked in a stable state, then the AS91L1003U will perform a loopback of TDI->Register->TDO.

Mode_Select Register (Bit 7 -> Bit 0)	LSP Configuration (If Port Unparked)
XXX0X000	TDI->Register->TDO
XXX0X001	TDI->Register->LSP1->PAD->TDO
XXX0X010	TDI->Register->LSP2->PAD->TDO
XXX0X011	TDI->Register->LSP1->PAD->LSP2->PAD->TDO
XXX0X100	TDI->Register->LSP3->PAD->TDO
XXX0X101	TDI->Register->LSP1->PAD->LSP3->PAD->TDO
XXX0X110	TDI->Register->LSP2->PAD->LSP3->PAD->TDO
XXX0X111	TDI->Register->LSP1->PAD->LSP2->PAD->LSP3->PAD->TDO

Table 7 - Mode Select Register Mapping

X = don't care

Register = AS91L1003U device instruction register or any of the AS91L1003U device test data registers.

PAD = Insertion of a 1-bit register for data synchronization.

Upon entering Test-Logic-Reset, the register bits will be loaded with "0000000".



Pass-Through Support within the AS91L1003U Device

The AS91L1003U device supports a Pass-Through mode where the primary or master IEEE1149.1 JTAG signals can be routed to any one of the LSPs. When this mode is activated, the "Debug Enable" signal for that LSP will go active, which can be used to place a processor such as the MPC8260 into BDM (Background Debug Mode) if required. If no processors are present in

the LSP, the Pass-Through mode can be used to assist in the generation of the test vectors or memory tests for the devices that are linked into the selected LSP. The pass-through feature has the effect of simplifying the test vector generation for the LSP, as it also has the effect of removing the AS91L1003U device from the test vector generation process.

PASS_THRU_ENABLE	PASS_THRU_SEL(1)	PASS_THRU_SEL(0)	Active LSP
High	X	X	Normal Operation
Low	Low	Low	LSP1
Low	Low	High	LSP2
Low	High	Low	LSP3

Table 8 – Pass-Through mode in AS91L1003U



Note: When PASS_THRU_ENABLE enable is deasserted (logic "1"), then the LSPs are under control of the AS91L1003U device logic. When PASS_THRU_ENABLE is asserted (logic "0") and if an invalid combination is presented on the PASS_THRU_SEL lines, then all LSPs are tri-stated.



Signal Description

PIN NAME	PIN TYPE	PIN NUMBER LQFP	PIN NUMBER FPBGA	DESCRIPTION	Stable signals states, with device unselected and active outputs on the device
LSP1_TCK	OUT	31	H4	IEEE1149.1 Test Clock on Local Scan Port 1 when PASS_THRU_ENABLE is HIGH. Pin is in Pass-Through mode when PASS_THRU_ENABLE = 0 and PASS_THRU_SEL[1:0] = 00. This pin is tri-stated for all other combinations.	Buffered version of signal present on primary TCK
LSP1_TMS	OUT	32	J4	IEEE1149.1 Test Mode Select on Local Scan Port 1 when PASS_THRU_ENABLE is HIGH. Pin is in Pass-Through mode when PASS_THRU_ENABLE = 0 and PASS_THRU_SEL[1:0] = 00. This pin is tri-stated for all other combinations.	Logic '1'
LSP1_TDO	OUT	35	H5	IEEE1149.1 Test Data Out on Local Scan Port 1 when PASS_THRU_ENABLE is HIGH. Pin is in Pass-Through mode when PASS_THRU_ENABLE = 0 and PASS_THRU_SEL[1:0] = 00. This pin is tri-stated for all other combinations.	Logic '1'
LSP1_TDI	IN	33	K4	IEEE1149.1 Test Data In on Local Scan Port 1 when PASS_THRU_ENABLE is HIGH. Pin is in Pass-Through mode when PASS_THRU_ENABLE = 0 and PASS_THRU_SEL[1:0] = 00.	
LSP1_TRST	OUT	29	K3	IEEE1149.1 Test Reset on Local Scan Port 1 when PASS_THRU_ENABLE is HIGH. Pin is in Pass-Through mode when PASS_THRU_ENABLE = 0 and PASS_THRU_SEL[1:0] = 00. This pin is tri-stated for all other combinations.	Buffered version of signal present on primary TRST



PIN NAME	PIN TYPE	PIN NUMBER LQFP	PIN NUMBER FPBGA	DESCRIPTION	Stable signals states, with device unselected and active outputs on the device
LSP1_AutoWR	OUT	30	J3	Flash, Memory Auto-Write on Local Scan Port 1 when PASS_THRU_ENABLE is HIGH. Pin is in Pass-Through mode when PASS_THRU_ENABLE = 0 and PASS_THRU_SEL[1:0] = 00. This pin is tri-stated for all other combinations.	Logic '1'
LSP1_DE	OUT	28	J2	Pass-Through Debug Enable Output on Local Scan Port 1. Active low output when PASS_THRU_ENABLE = 0 and PASS_THRU_SEL[1:0] = 00. This pin is high for all other combinations.	Logic '1'
LSP2_TCK	OUT	41	J6	IEEE1149.1 Test Clock on Local Scan Port 2 when PASS_THRU_ENABLE is HIGH. Pin is in Pass-Through mode when PASS_THRU_ENABLE = 0 and PASS_THRU_SEL[1:0] = 01. This pin is tri-stated for all other combinations.	Buffered version of signal present on primary TCK
LSP2_TMS	OUT	42	H6	IEEE1149.1 Test Mode Select on Local Scan Port 2 when PASS_THRU_ENABLE is HIGH. Pin is in Pass-Through mode when PASS_THRU_ENABLE = 0 and PASS_THRU_SEL[1:0] = 01. This pin is tri-stated for all other combinations.	Logic '1'
LSP2_TDO	OUT	45	J7	IEEE1149.1 Test Data Out on Local Scan Port 2 when PASS_THRU_ENABLE is HIGH. Pin is in Pass-Through mode when PASS_THRU_ENABLE = 0 and PASS_THRU_SEL[1:0] = 01. This pin is tri-stated for all other combinations.	Logic '1'



PIN NAME	PIN TYPE	PIN NUMBER LQFP	PIN NUMBER FPBGA	DESCRIPTION	Stable signals states, with device unselected and active outputs on the device
LSP2_TDI	IN	44	K7	IEEE1149.1 Test Data In on Local Scan Port 2 when PASS_THRU_ENABLE is HIGH. Pin is in Pass-Through mode when PASS_THRU_ENABLE = 0 and PASS_THRU_SEL[1:0] = 01.	
LSP2_TRST	OUT	37	K5	IEEE1149.1 Test Reset on Local Scan Port 2 when PASS_THRU_ENABLE is HIGH. Pin is in Pass-Through mode when PASS_THRU_ENABLE = 0 and PASS_THRU_SEL[1:0] = 01. This pin is tri-stated for all other combinations.	Buffered version of signal present on primary TRST
LSP2_AutoWR	OUT	40	K6	Flash, Memory Auto-Write on Local Scan Port 2 when PASS_THRU_ENABLE is HIGH. Pin is in Pass-Through mode when PASS_THRU_ENABLE = 0 and PASS_THRU_SEL[1:0] = 01. This pin is tri-stated for all other combinations.	Logic '1'
LSP2_DE	OUT	36	J5	Pass-Through Debug Enable Output on Local Scan Port 2. Active low output when PASS_THRU_ENABLE = 0 and PASS_THRU_SEL[1:0] = 01. This pin is high for all other combinations.	Logic '1'
LSP3_TCK	OUT	49	K9	IEEE1149.1 Test Clock on Local Scan Port 3 when PASS_THRU_ENABLE is HIGH. Pin is in Pass-Through mode when PASS_THRU_ENABLE = 0 and PASS_THRU_SEL[1:0] = 10. This pin is tri-stated for all other combinations.	Buffered version of signal present on primary TCK



PIN NAME	PIN TYPE	PIN NUMBER LQFP	PIN NUMBER FPBGA	DESCRIPTION	Stable signals states, with device unselected and active outputs on the device
LSP3_TMS	OUT	50	K10	IEEE1149.1 Test Mode Select on Local Scan Port 3 when PASS_THRU_ENABLE is HIGH. Pin is in Pass-Through mode when PASS_THRU_ENABLE = 0 and PASS_THRU_SEL[1:0] = 10. This pin is tri-stated for all other combinations.	Logic '1'
LSP3_TDO	OUT	53	H10	IEEE1149.1 Test Data Out on Local Scan Port 3 when PASS_THRU_ENABLE is HIGH. Pin is in Pass-Through mode when PASS_THRU_ENABLE = 0 and PASS_THRU_SEL[1:0] = 10. This pin is tri-stated for all other combinations.	Logic '1'
LSP3_TDI	IN	52	J10	IEEE1149.1 Test Data In on Local Scan Port 3 when PASS_THRU_ENABLE is HIGH. Pin is in Pass-Through mode when PASS_THRU_ENABLE = 0 and PASS_THRU_SEL[1:0] = 10.	
LSP3_TRST	OUT	47	J8	IEEE1149.1 Test Reset on Local Scan Port 3 when PASS_THRU_ENABLE is HIGH. Pin is in Pass-Through mode when PASS_THRU_ENABLE = 0 and PASS_THRU_SEL[1:0] = 10. This pin is tri-stated for all other combinations.	Buffered version of signal present on primary TRST
LSP3_LSP_AutoWR	OUT	48	K8	Flash, Memory Auto-Write on Local Scan Port 3 when PASS_THRU_ENABLE is HIGH. Pin is in Pass-Through mode when PASS_THRU_ENABLE = 0 and PASS_THRU_SEL[1:0] = 10. This pin is tri-stated for all other combinations.	Logic '1'



PIN NAME	PIN TYPE	PIN NUMBER LQFP	PIN NUMBER FPBGA	DESCRIPTION	Stable signals states, with device unselected and active outputs on the device
LSP3_DE	OUT	46	H7	Pass-Through Debug Enable Output on Local Scan Port 3. Active low output when PASS_THRU_ENABLE = 0 and PASS_THRU_SEL[1:0] = 10. This pin is high for all other combinations.	Logic '1'
PRIM_TCK	IN	87	A6	IEEE1149.1 Primary Test Clock Input.	
PRIM_TMS	IN	21	G2	IEEE1149.1 Primary Test Mode Select Input.	
PRIM_TDO	OUT	20	G1	IEEE1149.1 Primary Test Data Output. This pin is tri-stated when AS91L1003 is not selected.	HighZ
PRIM_TDI	IN	19	G3	IEEE1149.1 Primary Test Data Input	
PRIM_TRST	IN	22	H2	IEEE1149.1 Primary Test Reset Input. This active low asynchronous reset input signal places AS91L1003U in Wait-for-Selection state.	
PRIM_AutoWR	IN	16	F1	Primary Auto-Write Input controlled by test equipment to shorten Flash memory programming.	
S[5:0]	IN	8,7,6,5,100,99	D2,D1,D3,C2,B2,A2	Slot Address (5:0) Inputs. Used to set address at which AS91L1003U will respond; typically set by hardwired connection on the backplane.	
*TOE	IN	88	B6	Test Output Enable Input. Tri-states all LSPs, when asserted low.	
LSP_RESET_n	IN	14	F4	Local Scan Port Reset Input. Active low resets AS91L1003U to "Wait-for-Selection" state and pulses all LSP TRST output pins to low. This resets all devices with TRST function; typically this signal would be connected to a power-on-reset function.	



PIN NAME	PIN TYPE	PIN NUMBER LQFP	PIN NUMBER FPBGA	DESCRIPTION	Stable signals states, with device unselected and active outputs on the device
AS91L1003U_SELECTED	OUT	25	K1	AS91L1003U_Selected Output. Active low when AS91L1003U is selected; typically used to control off board buffering.	
LSP_ENABLE	OUT	24	J1	Local Scan Port Enable Output. Active low output when AS91L1003U is selected; typically used to set IEEE1149.1 compliance enable pins on devices.	
USERCODE [15:0]	IN	64,65,67,68,69,70,71,72,75,76,77,78,79,80,81,83 (MSB-LSB)	E9,E10,E8,E7,D9,D10,D8,C9,C10,B10,B9,A9,A8,B8,A7,B7 (MSB-LSB)	User/Board Identification Inputs. Used to establish board type and revision so as to ensure correct IEEE1149.1 test vector sets are applied.	
USER_STATUS_BYTE[7:0]	IN	84, 85, 92, 93, 94, 96, 97, 98 (MSB-LSB)	C7,C6,C5,C4,B4,A4,B3,A3 (MSB-LSB)	USER_Status_Byte Inputs. Used to provide status information of the PCB under test back to the test master via the IEEE1149.1 bus. Eight signals levels can be monitored and then reported via the IEEE1149.1 bus in a non intrusive manner.	
SELF_TEST	OUT	27	K2	Provides a low going output pulse under command from the IEEE1149.1 bus, which can be used to start self-test functions on a PCB.	Logic '1'
PASS_THRU_ENABLE	IN	9	E4	PASS_THRU Enable Input. Active high disables Pass-Through mode. Active low enables Pass-Through mode.	
PASS_THRU_SEL[1:0]	IN	12,10	E1,E3	PASS_THRU Select Inputs. Used to select active routing of Pass-Through ports enabled by active low on PASS_THRU_ENABLE pin. 00 = LSP1 01 = LSP 10 = LSP3	



PIN NAME	PIN TYPE	PIN NUMBER LQFP	PIN NUMBER FPBGA	DESCRIPTION	Stable signals states, with device unselected and active outputs on the device
GND	POWER	38, 86, 11, 26, 43, 59, 74, 95, 2, 17, 54, 90	D6, G5, C3, D7, E5, F6, G4, H8, H9, J9, B1, A5, F2	Ground Pins.	
VCC	POWER	39, 91, 3, 18, 34, 51, 66, 82, 23, 55, 56	D5, G6, C8, D4, E6, F5, G7, H3, G9, H1	VCC pins.	
ASIC_TEST_EN	IN	89	B5	Factory Test_Enable Input. This pin should be left unconnected.	
ASIC_TCK	IN	62	F8	IEEE1149.1 ASIC Test Clock Input.	
ASIC_TMS	IN	15	F3	IEEE1149.1 ASIC Test Mode Select Input.	
ASIC_TDO	OUT	73	A10	IEEE1149.1 ASIC Test Clock Output.	
ASIC_TDI	IN	4	A1	IEEE1149.1 ASIC Test Clock Input.	
No Connects		1, 13, 63, 61, 60, 58, 57	C1, E2, F7, F10, F9, G8, G10		

Table 10 - AS91L0003U Signal Description



Absolute Maximum Ratings

Parameter	Maximum Range
Supply Voltage (Vcc)	-0.3V to 5.5V
DC Input Voltage (Vi)	-0.5V to Vcc +0.5V
Max sink current when Vi = -0.5V	-20mA
Max source current when Vi = Vcc + 0.5V	+20mA
Max Junction Temperature with power applied Tj	+125 degrees C
Max Storage temperature	-55 to +150 degree C

Table 11 - Absolute Maximum Ratings



Note: Stress above the stated maximum values may cause irreparable damage to the device. Correct operation of the device at these values is not guaranteed.

Recommended Operating Conditions

Parameter	Operating Range
Supply Voltage (Vcc)	3.0V to 3.6V
Input Voltage (Vi)	0V to Vcc
Output Voltage (Vo)	0V to Vcc
Operating Temperature (Ta) Commercial	0 C to 70 C
Industrial (Ta)	-40 deg C to +85 deg C, 3.00V to 3.6V

Table 12 - Recommended Operating Conditions



AC Electrical Characteristics

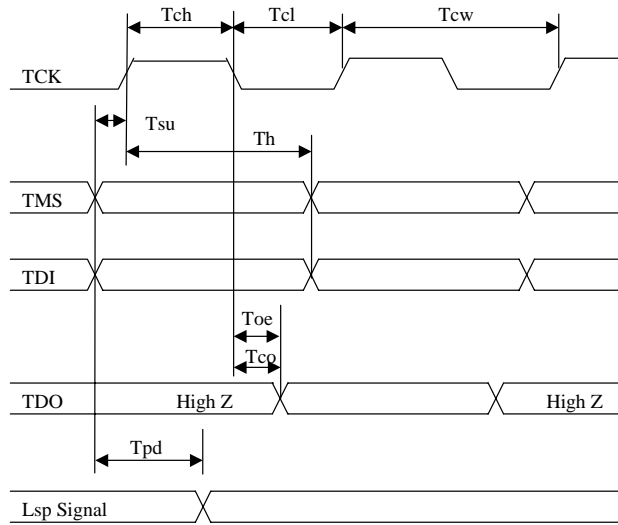

Figure 4 - AS91L1003U AC Timing Diagram

SYMBOL	Parameter	MIN	MAX	UNITS
Tcw	TCK clock pulse width	100	-	ns
Tch	TCK pulse width high	50	-	ns
Tcl	TCK pulse width low	50	-	ns
Tsu	TCK Setup time	30	-	ns
Th	TCK Hold time	40	-	ns
Toe	Neg Edge TCK to valid data enable	20	-	ns
Tco	Neg Edge TCK to valid data	15	-	ns
Tpd	Pass through Mode Primary/LSP Delay	-	10	ns

Table 9 - AS91L1003U AC Timing Information



DC Electrical Characteristics

Symbol	Parameter	Min	Max	Condition
V _{IH}	Minimum High Input Voltage	2.0	5.25	
V _{IL}	Maximum Low Input Voltage	-0.3V	0.8V	
Symbol	Parameter		Value	Condition
V _{OH}	Minimum High Output Voltage		2.4V	I _{oh} =24mA or 8mA as defined by pin
V _{OL}	Minimum Low Output Voltage		0.4V	I _{ol} =24mA or 8mA as defined by pin
I _{oz}	Tristate output leakage		-10 or 10 mA	
I _{cc}	Maximum quiescent supply current		2mA	
I _{ccd}	Maximum dynamic supply current		80mA	TCK freq equal to 10 MHz

Table 13 - AS91L1003U DC Electrical Characteristics

Packaging Information

The AS91L1003U is available in a 100-pin LQFP or a 100-pin FPBGA lead free package.

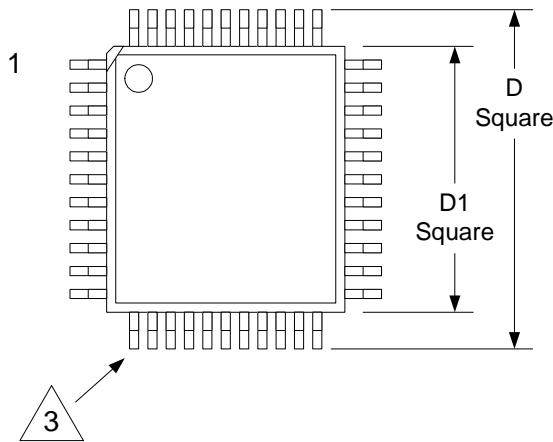

SYMBOL	LEADS		100 LEAD
	TOL.		
A	MAX.		1.60
A ₁	MIN / MAX		0.05 / 0.15
A ₂	MIN / NOM / MAX		1.35 / 1.40 / 1.45
D	BASIC		18.00
D ₁	BASIC		14.00
L	±0.15		0.60
L ₁	REF		1.00
b	MIN / MAX		0.17 / 0.27
e	BASIC		0.50
ccc	MAX		0.08
ddd	NOM		0.08
JEDEC REF #			MS-026

- NOTES:
- ALL LINEAR DIMENSIONS ARE IN MILLIMETERS.
 - PLASTIC BODY DIMENSIONS DO NOT INCLUDE FLASH OR PROTUSION. MAX ALLOWABLE 0.25 PER SIDE.
 - LEAD COUNT ON DRAWING NOT REPRESENTATIVE OF ACTUAL PACKAGE.

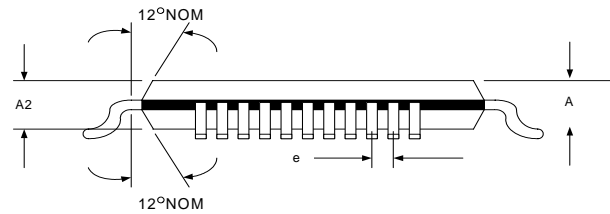
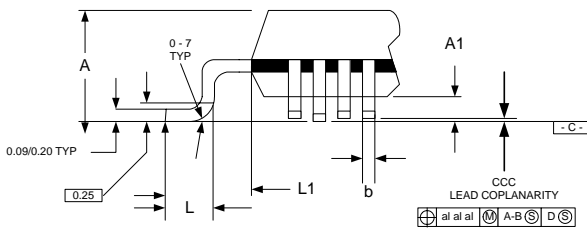
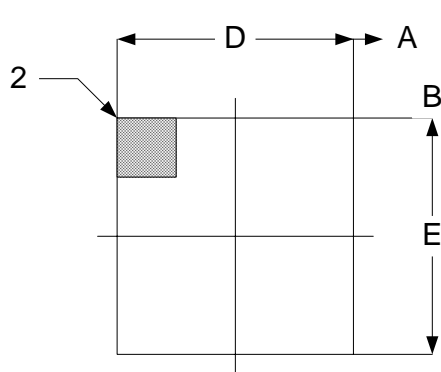
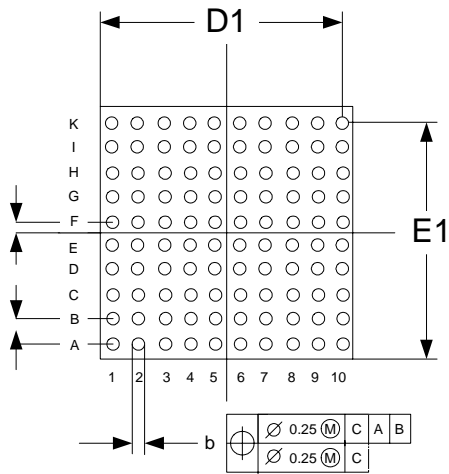
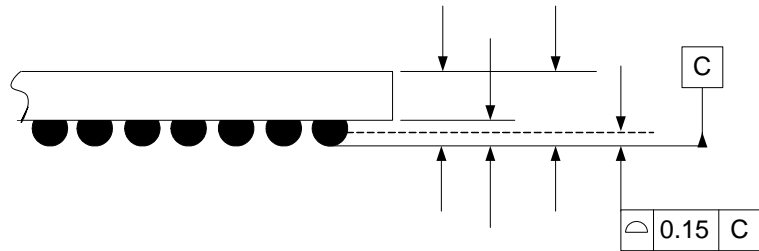

Figure 5 - LQFP-100



Revisions			
REV.	DESCRIPTION	ECN	DATE
A	Initial document release.	91253	12-04-01
B	Updated ball coplanarity limits from 0.20mm to 0.15mm.		



DIMENSIONS			
SYMBOL	MIN.	NOM.	MAX.
A	--	--	1.70
A1	0.30	--	--
A2	0.25	--	1.10
b	0.50	0.60	0.70
D	11.00 BSC		
D1	9.00 BSC		
E	11.00 BSC		
E1	9.00 BSC		
e	1.00		
PACKAGE NUMBER	FBGA0100-11F		
JEDEC REF #	MO-192 VAR. AAC-1		

Figure 6 - FPBGA-100



Device Selector Guide and Ordering Information

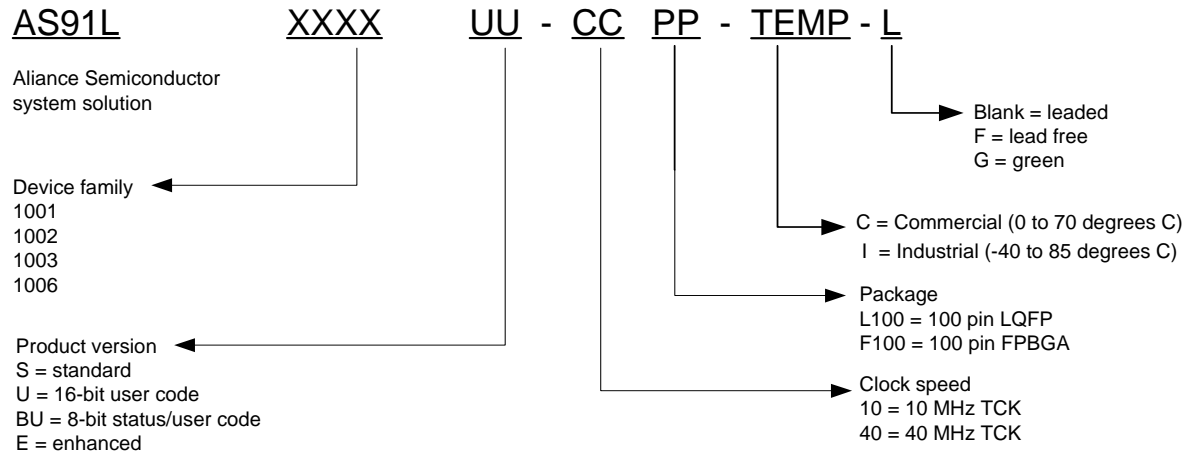

Figure 7 - Part Numbering Guide



Part Number	Description
AS91L1003U – 10L100-C	3-Port JTAG Gateway, 100-pin LQFP package, commercial
AS91L1003U – 10L100-CF	3-Port JTAG Gateway, 100-pin LQFP package, commercial, lead free
AS91L1003U – 10L100-I	3-Port JTAG Gateway, 100-pin LQFP package, industrial
AS91L1003U – 10L100-IF	3-Port JTAG Gateway, 100-pin LQFP package, industrial, lead free
AS91L1003U – 10F100-C	3-Port JTAG Gateway, 100-pin FPBGA package, commercial
AS91L1003U – 10F100-CG	3-Port JTAG Gateway, 100-pin FPBGA, commercial, green package
AS91L1003U – 10F100-I	3-Port JTAG Gateway, 100-pin FPBGA package, industrial
AS91L1003U – 10F100-IG	3-Port JTAG Gateway, 100-pin FPBGA, industrial, green package
AS91L1003U – 40L100-CF	3-Port JTAG Gateway, 100-pin LQFP package, commercial, lead free, 40 MHz TCK
AS91L1003U – 40L100-IF	3-Port JTAG Gateway, 100-pin LQFP package, industrial, lead free, 40 MHz TCK
AS91L1003U – 40F100-CG	3-Port JTAG Gateway, 100-pin FPBGA, commercial, green package, 40 MHz TCK
AS91L1003U – 40F100-IG	3-Port JTAG Gateway, 100-pin FPBGA, industrial, green package, 40 MHz TCK

Table 14 - Valid Part Number Combinations



Device Master	Description	Package Options	
		FPBGA-100 (1mm pitch)	LQFP-100
AS91L1001	JTAG Test Controller	X	X
AS91L1002	JTAG Test Sequencer	X	X
AS91L1003U	3-Port Gateway	X	X
AS91L1006BU	6-Port Gateway	X	X

Table 15 - JTAG Controller Product Family

