

Termination Regulator for DDR-SDRAMs

BD3537F

General Description

BD3537F is a termination regulator that complies with JEDEC requirements for DDR-SDRAM. This linear power supply uses a built-in N-channel MOSFET and high-speed OP-AMPS specially designed to provide excellent transient response. It has a sink/source current capability up to 1.8A and has a power supply bias requirement of 5.0V for driving the N-channel MOSFET. For BD3537F, ceramic capacitor can be used as output capacitor enabling significant package profile downsizing as the total regulator part.

Features

- Incorporates a Push-Pull Power Supply for Termination (VTT)
- Incorporates an Enabler
- Incorporates an Undervoltage Lockout (UVLO)
- Incorporates a Thermal Shutdown Protector (TSD)
- Compatible with Dual Channel (DDR-II)
- Incorporates Soft-start Function

Applications

Power supply for DDR I/II - SDRAM

Key Specifications

- Termination Input Voltage Range: 1.746V to 1.854V
- VCC Input Voltage Range: 4.75V to 5.25V
- Output Current: 1.8A (Max)
- High side FET ON-Resistance: 0.3Ω(Typ)
- Low side FET ON-Resistance: 0.3Ω(Typ)
- Standby Current: 50μA (Typ)
- Operating Temperature Range: -30°C to +100°C

Package

W(Typ) x D(Typ) x H(Max)

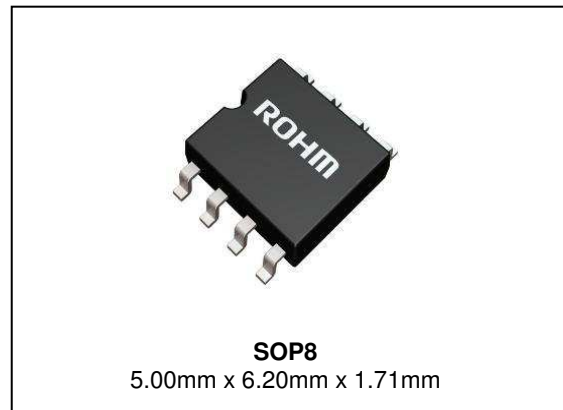

Typical Application Circuit, Block Diagram

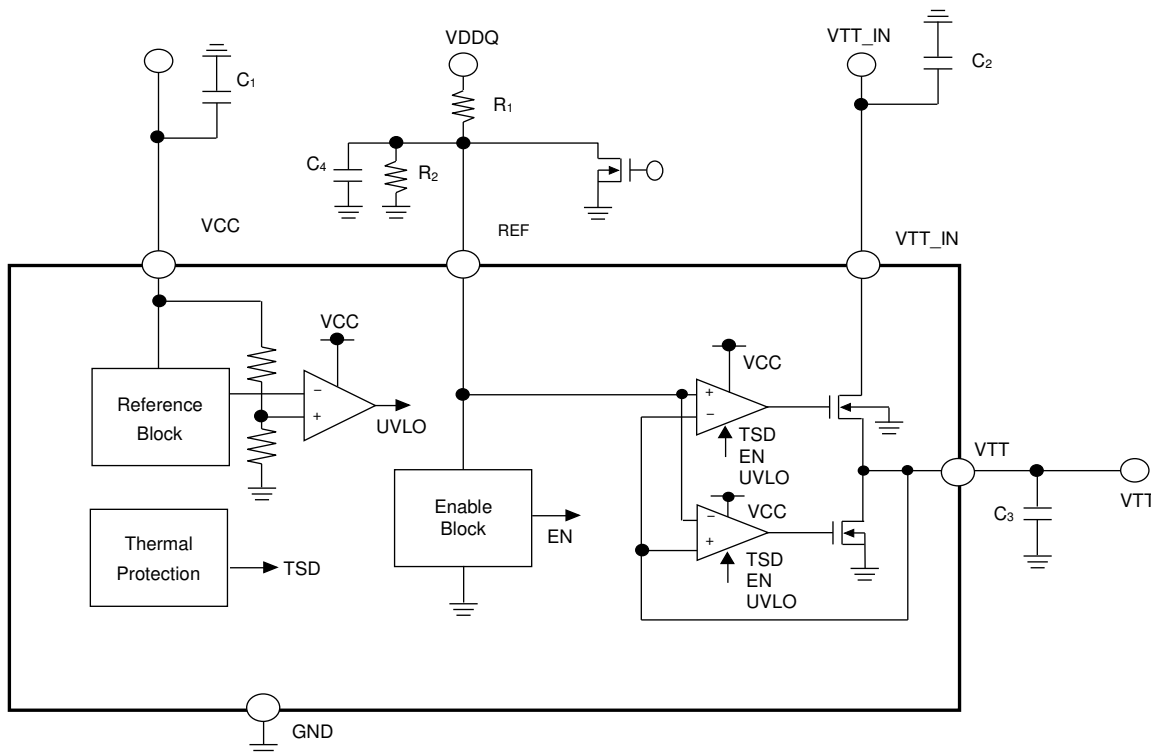

Pin Configuration

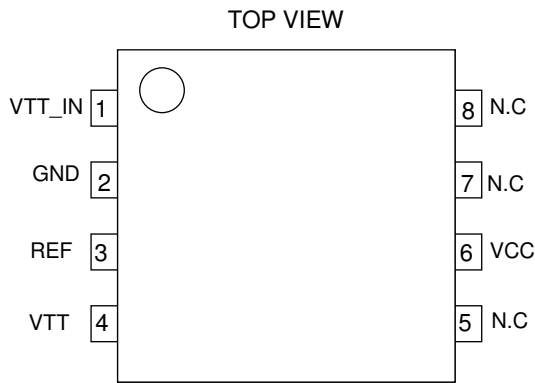

Pin Descriptions

Pin No.	Pin Name	Pin Function
1	VTT_IN	Termination power supply pin
2	GND	Ground pin
3	REF	Reference voltage output pin
4	VTT	Termination output pin
5	N.C	Non connection
6	VCC	VCC pin
7	N.C	Non connection
8	N.C	Non connection

Description of Blocks

- VCC**
The VCC pin is for the independent power supply input that operates the external circuit of the IC. It is the voltage pin that drives the IC's amplifier circuits. The VCC input is 5V and the maximum current consumption is 2.5mA. A bypass capacitor of 1 μ F or so should be connected to this pin when using the IC in an application circuit.
- VTT_IN**
VTT_IN is a power supply input pin for VTT output. Input voltage may range up to 1.8V, but consideration must be given to the current limit dictated by the ON-Resistance of the IC and the change in allowable loss due to input/output voltage difference.

Take note that a high-impedance voltage input at VTT_IN may result in oscillation or degradation in ripple rejection, so connecting a 10 μ F capacitor with minimal change in capacitance to VTT_IN terminal is recommended. However, the impedance may depend on the characteristics of the power supply input and the impedance of the PC board wiring, which must be carefully checked before use.

- VTT**
VTT is the output pin for the DDR memory termination voltage and it has a sink/source current capability of ± 1.8 A. The output voltage is same as REF voltage. The output is turned to OFF when REF pin is "LOW" or when either the VCC UVLO or thermal shutdown protection function is activated.

Always connect a capacitor to VTT pin for a loop gain and phase compensation and a reduction in output voltage variation in the event of sudden load change. Be careful in choosing the capacitor as insufficient capacitance may cause an oscillation and high ESR (Equivalent Series Resistance) may result in increased output voltage variation during a sudden change in load. A 10 μ F or so ceramic capacitor is recommended, though ambient temperature and other conditions should also be considered. A low ESR ceramic capacitor may reduce a loop gain phase margin and may cause an oscillation, which may be improved by connecting a resistor in series with the OS - capacitor (several - hundred μ F).

- REF**
A "High" input of 0.6V or higher to REF turns ON the VTT output. A "Low" input of 0.15 V or less, on the other hand, turns VTT to a Hi-Z state.

Absolute Maximum Ratings

Parameter	Symbol	Limit	Unit
Input Voltage	V _{CC}	7 (Note 1)	V
REF Input Voltage	V _{REF}	7 (Note 1)	V
Termination Input Voltage	V _{VTT_IN}	7 (Note 1)	V
Output Current	I _{VTT}	1.8	A
Power Dissipation1	Pd1	0.56 (Note 2)	W
Power Dissipation2	Pd2	0.69 (Note 3)	W
Operating Temperature Range	Topr	-30 to +100	°C
Storage Temperature Range	Tstg	-55 to +150	°C
Maximum Junction Temperature	Tjmax	+150	°C

(Note 1) Should not exceed Pd.

(Note 2) Derate by 4.48mW/°C for Ta over 25°C (no heat sink).

(Note 3) Derate by 5.52mW/°C for Ta over 25°C (when mounted on 70mm x 70mm x 1.6mm Glass-epoxy PCB).

Caution: Operating the IC over the absolute maximum ratings may damage the IC. In addition, it is impossible to predict all destructive situations such as short-circuit modes, open circuit modes, etc. Therefore, it is important to consider circuit protection measures, like adding a fuse, in case the IC is operated in a special mode exceeding the absolute maximum ratings

Recommended Operating Conditions (Ta=25°C)

Parameter	Symbol	Min	Max	Unit
Input Voltage	V _{CC}	4.75	5.25	V
Termination Input Voltage	V _{VTT_IN}	1.746	1.854	V
Reference Voltage	V _{REF}	0.6	1.6	V

Electrical Characteristics

(Unless otherwise noted, Ta=25°C, V_{CC}=5V, V_{REF}=0.9V, V_{VTT_IN}=1.8V)

Parameter	Symbol	Standard Value			Unit	Conditions
		Min	Typ	Max		
Standby Current	I _{ST}	-	50	90	μA	V _{REF} < 0.15V(Shutdown)
Bias Current	I _{CC}	-	1	2.5	mA	V _{REF} = 0.9V
[Termination]						
Termination Output Voltage 1	V _{VTT1}	V _{REF} -20m	V _{REF}	V _{REF} +20m	V	I _{VTT} = 0A
Termination Output Voltage 2	V _{VTT2}	V _{REF} -20m	V _{REF}	V _{REF} +20m	V	I _{VTT} = -1.8A to +1.8A
Source Current	I _{VTT+}	1.8	-	-	A	
Sink Current	I _{VTT-}	-	-	-1.8	A	
Upper Side ON-Resistance 1	R _{Hron1}	-	0.3	0.5	Ω	
Lower Side ON-Resistance 1	R _{Lron1}	-	0.3	0.5	Ω	
[UVLO block]						
UVLO Threshold Voltage	V _{UVLO}	3.5	3.8	4.1	V	V _{CC} : sweep up
UVLO Hysteresis Voltage	ΔV _{UVLO}	100	160	220	mV	V _{CC} : sweep down
[Enable Block]						
EN-ON Voltage	V _{ENH}	0.6	-	-	V	
EN-OFF Voltage	V _{ENL}	-	-	0.15	V	

Typical Waveforms

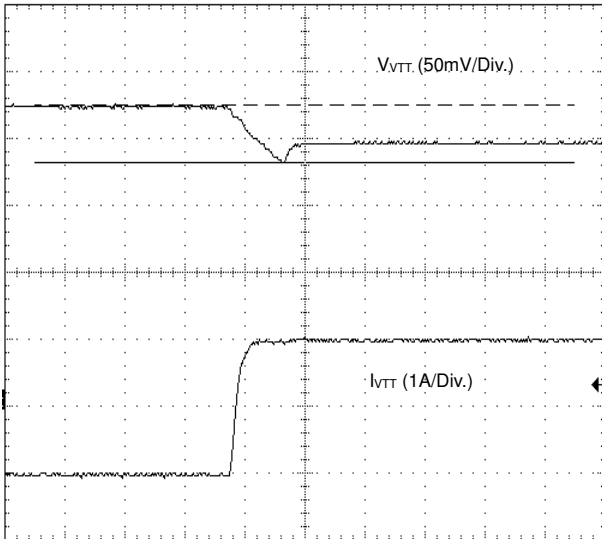

Figure 1. DDRI
(-1A → +1A)

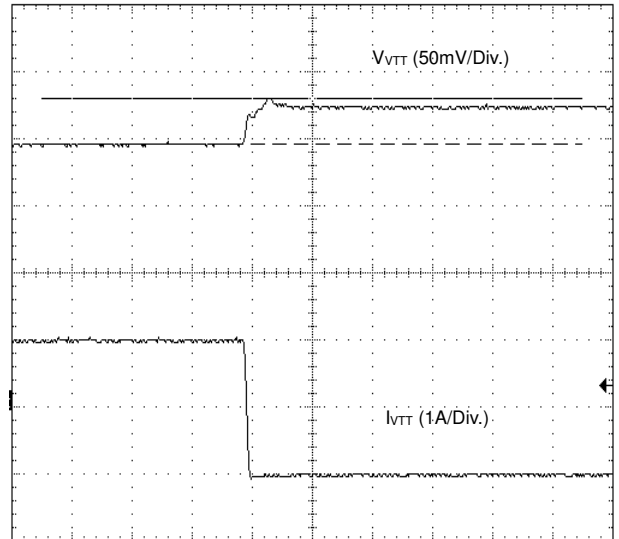

Figure 2. DDRI
(+1A → -1A)

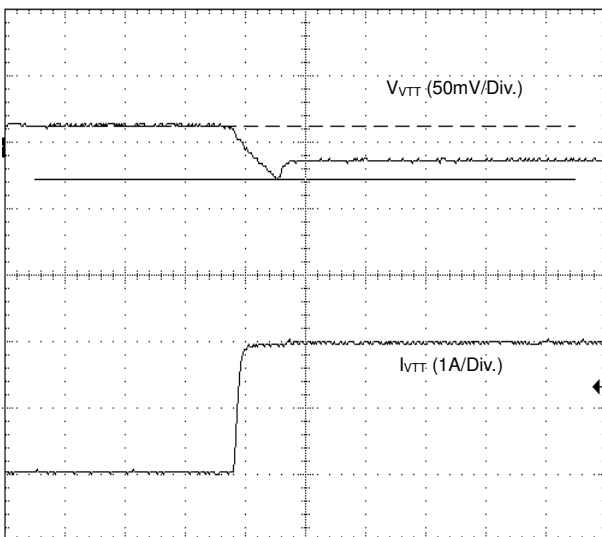

Figure 3. DDR II
(-1A → +1A)

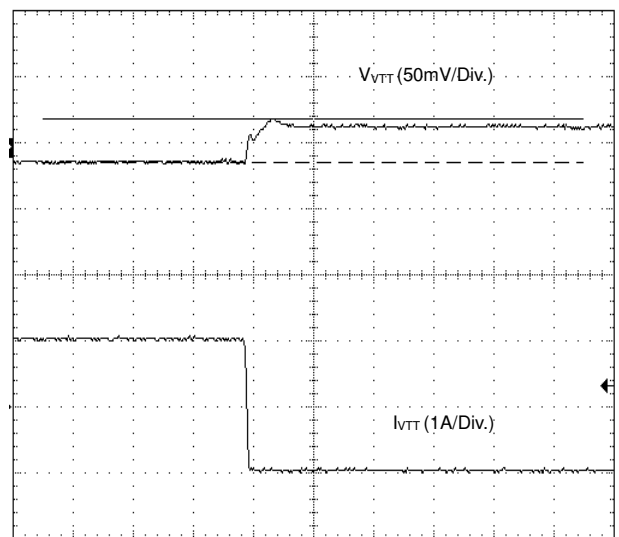

Figure 4. DDR II
(-1A → +1A)

Typical Waveforms – continued

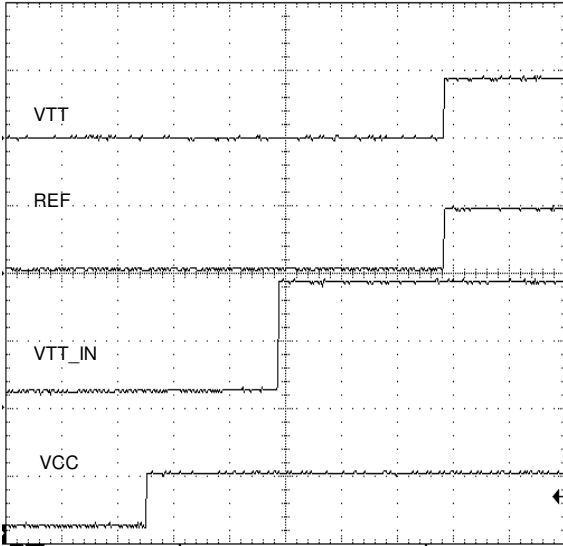

Figure 5. Input Sequence 1

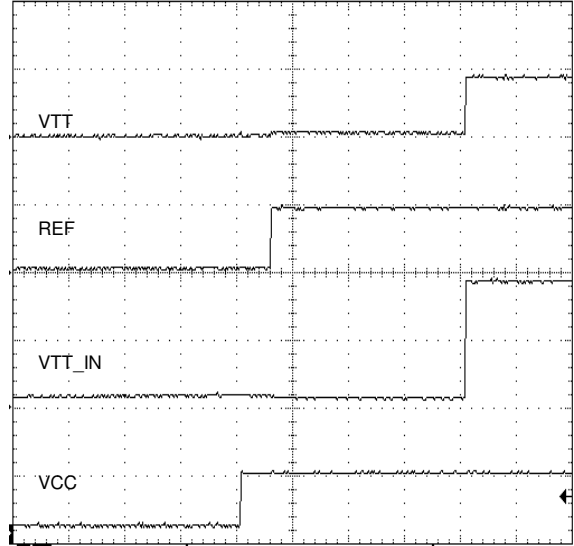

Figure 6. Input Sequence 2

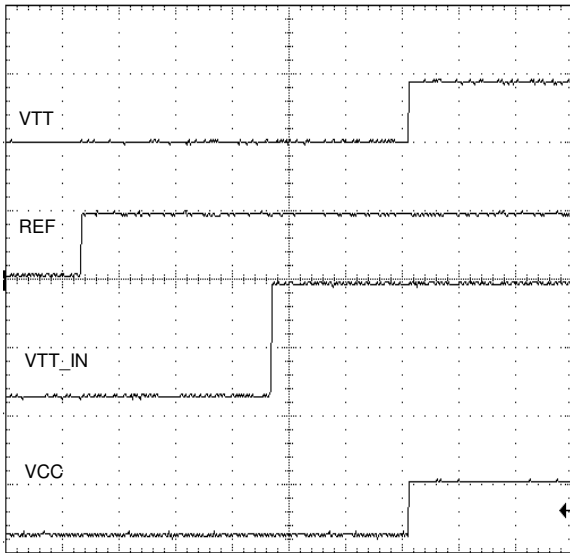

Figure 7. Input Sequence 3

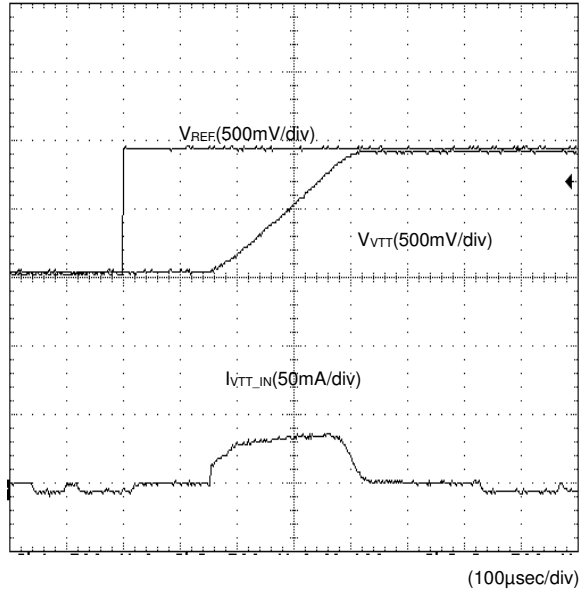

Figure 8. Soft Start

Typical Performance Curves

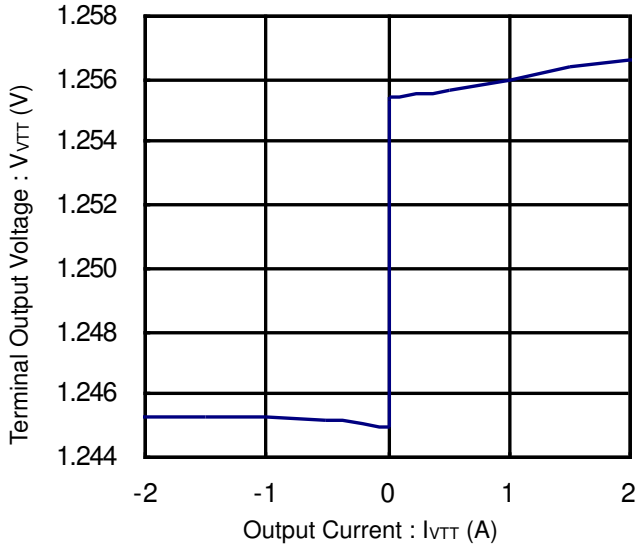

Figure 9. Terminal Output Voltage vs Output Current (DDR-I)

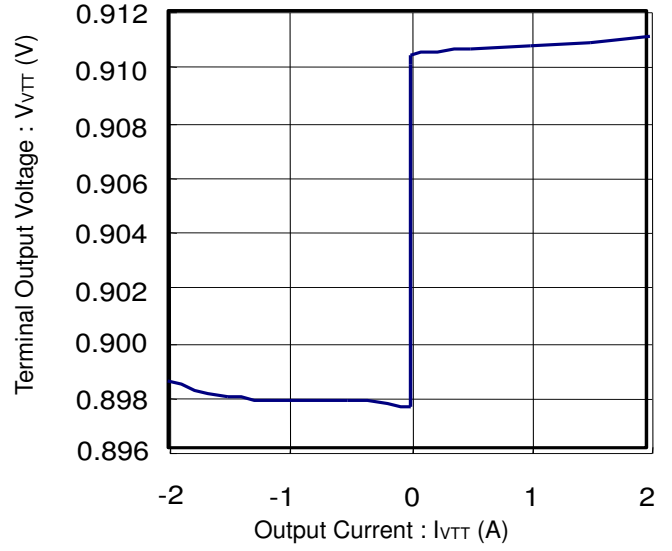
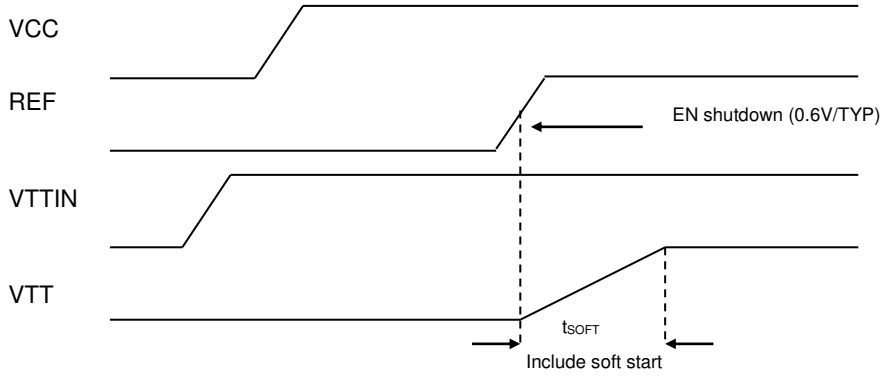

Figure 10. Terminal Output Voltage vs Output Current (DDR-II)

Application Information

1. Soft Start Function

(1) When input REF voltage



(2) When input VCC voltage

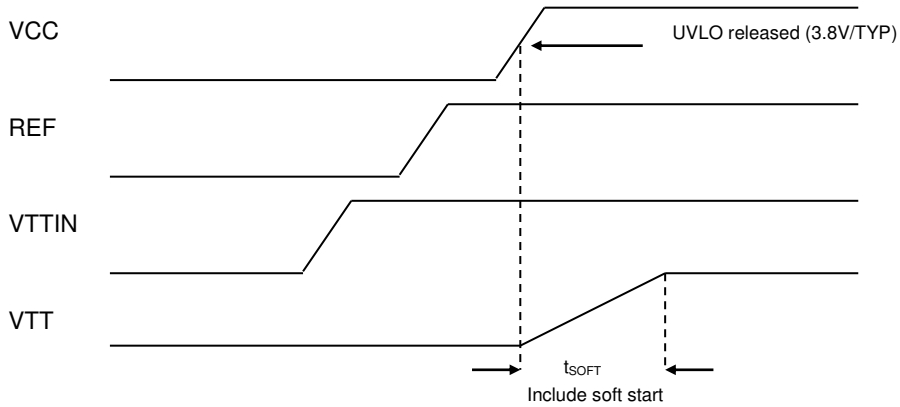

(3) When input VTTIN voltage

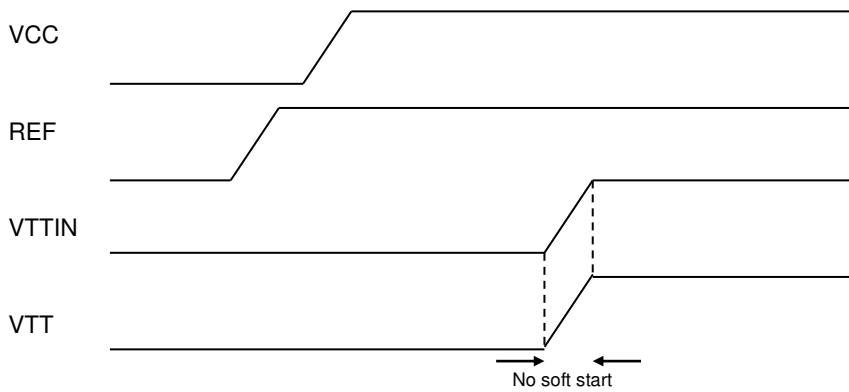

(Note) $t_{SOFT} \leq 1\text{msec}$

2. Evaluation Board

■BD3537F Evaluation Board circuit

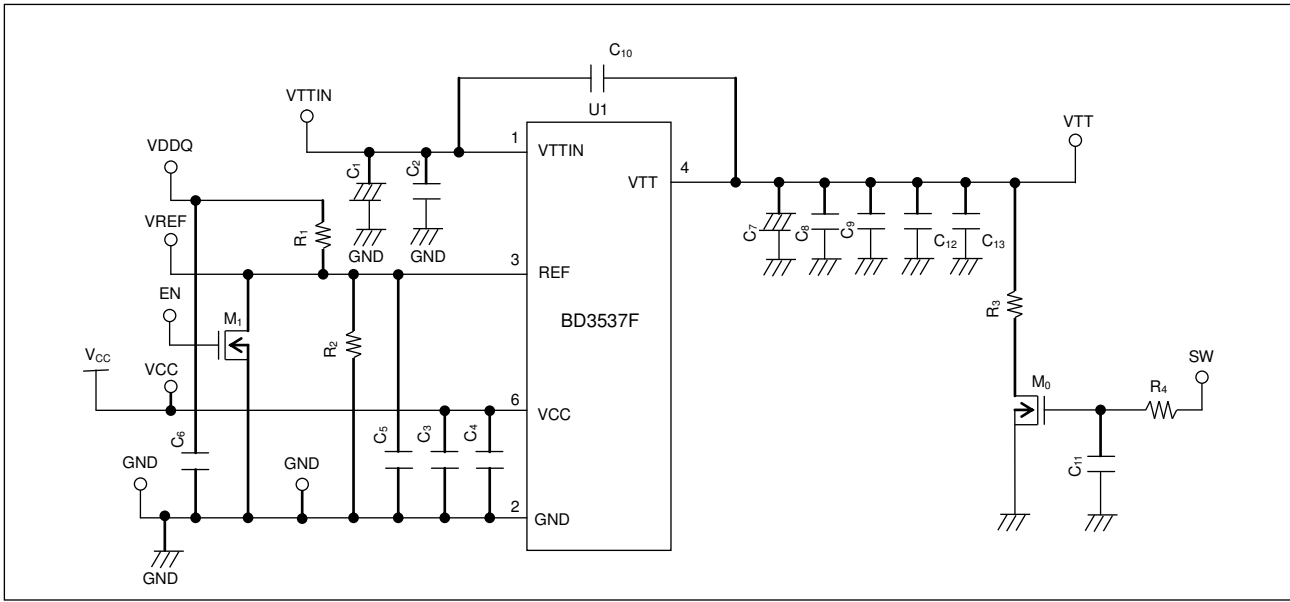

■BD3537F Evaluation Board Application Components

部品	定格	メーカー	型名
U1		ROHM	BD3537F
M0			
M1			
C1			
C2	10μF	KYOCERA	CM316B106M10A
C3	1μF	KYOCERA	CM05B105K10A
C4			
C5	1μF	KYOCERA	CM05B105K10A
C6			
C7			

部品	定格	メーカー	型名
C8			
C9	10μF	KYOCERA	CM316B106M10A
C10			
R1	100kΩ	ROHM	MCR03
R2	100kΩ	ROHM	MCR03
R3			
R4			
R5			
R6			

■BD3537F (SOP8) Evaluation Board Layout

Silk Screen

TOP Layer

Bottom Layer

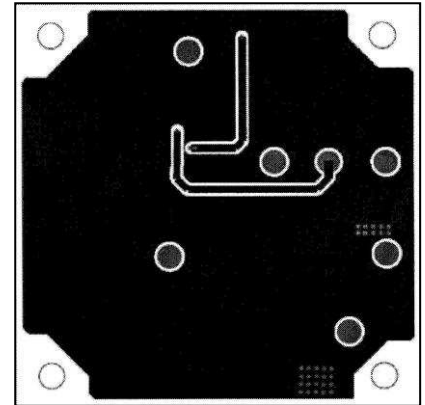
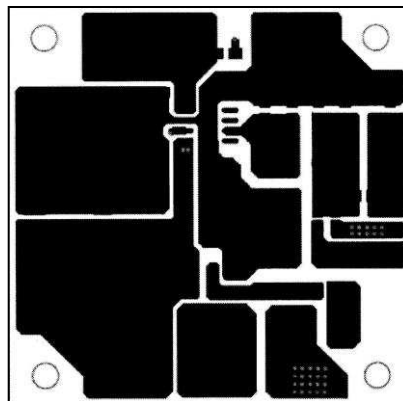
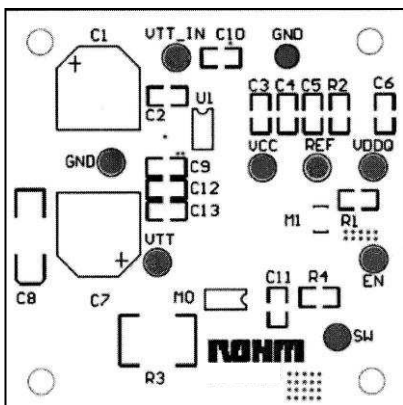

3. Power Dissipation

In thermal design, consider the temperature range where IC is guaranteed to operate and appropriate margins. The temperature conditions that need to be considered are listed below:

- (1) Ambient temperature Ta: 100°C or lower
- (2) Chip junction temperature Tj: 150°C or lower

The chip junction temperature Tj can be considered as follows:

Most of heat loss in BD3537F occurs at the output N-Channel FET. The lost power is determined by multiplying the voltage between IN and OUT by the output current. Since this IC is packaged for high-power applications, its thermal derating characteristics significantly depend on the PCB. So when designing, the size of the PCB to be used should be carefully considered.

$$\text{Power dissipation (W)} = \{ \text{Input voltage (V}_{V_{TT_IN}}) - \text{Output voltage (V}_{V_{TT} = V_{REF}}) \} \times I_{OUT} (\text{Ave})$$

If $V_{V_{TT_IN}}=1.8\text{V}$, $V_{REF}=0.9\text{V}$, and $I_{OUT} (\text{Ave})=0.5\text{A}$, for instance, the power dissipation is determined as follows:

$$\begin{aligned} \text{Power consumption (W)} &= \{ 1.8 (\text{V}) - 0.9 (\text{V}) \} \times 0.5 (\text{A}) \\ &= 0.4 (\text{W}) \end{aligned}$$

©SOP8(BD3537F)

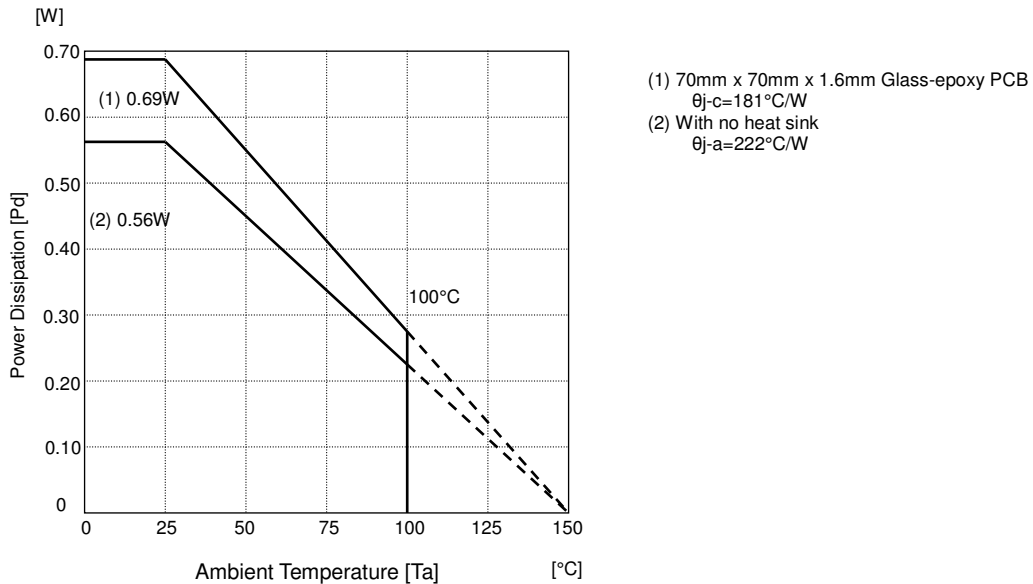

Operational Notes

1. Reverse Connection of Power Supply

Connecting the power supply in reverse polarity can damage the IC. Take precautions against reverse polarity when connecting the power supply, such as mounting an external diode between the power supply and the IC's power supply pins.

2. Power Supply Lines

Design the PCB layout pattern to provide low impedance supply lines. Separate the ground and supply lines of the digital and analog blocks to prevent noise in the ground and supply lines of the digital block from affecting the analog block. Furthermore, connect a capacitor to ground at all power supply pins. Consider the effect of temperature and aging on the capacitance value when using electrolytic capacitors.

3. Ground Voltage

Ensure that no pins are at a voltage below that of the ground pin at any time, even during transient condition.

4. Ground Wiring Pattern

When using both small-signal and large-current ground traces, the two ground traces should be routed separately but connected to a single ground at the reference point of the application board to avoid fluctuations in the small-signal ground caused by large currents. Also ensure that the ground traces of external components do not cause variations on the ground voltage. The ground lines must be as short and thick as possible to reduce line impedance.

5. Thermal Consideration

Should by any chance the power dissipation rating be exceeded the rise in temperature of the chip may result in deterioration of the properties of the chip. In case of exceeding this absolute maximum rating, increase the board size and copper area to prevent exceeding the Pd rating.

6. Recommended Operating Conditions

These conditions represent a range within which the expected characteristics of the IC can be approximately obtained. The electrical characteristics are guaranteed under the conditions of each parameter.

7. Inrush Current

When power is first supplied to the IC, it is possible that the internal logic may be unstable and inrush current may flow instantaneously due to the internal powering sequence and delays, especially if the IC has more than one power supply. Therefore, give special consideration to power coupling capacitance, power wiring, width of ground wiring, and routing of connections.

8. Operation Under Strong Electromagnetic Field

Operating the IC in the presence of a strong electromagnetic field may cause the IC to malfunction.

9. Testing on Application Boards

When testing the IC on an application board, connecting a capacitor directly to a low-impedance output pin may subject the IC to stress. Always discharge capacitors completely after each process or step. The IC's power supply should always be turned off completely before connecting or removing it from the test setup during the inspection process. To prevent damage from static discharge, ground the IC during assembly and use similar precautions during transport and storage.

10. Inter-pin Short and Mounting Errors

Ensure that the direction and position are correct when mounting the IC on the PCB. Incorrect mounting may result in damaging the IC. Avoid nearby pins being shorted to each other especially to ground, power supply and output pin. Inter-pin shorts could be due to many reasons such as metal particles, water droplets (in very humid environment) and unintentional solder bridge deposited in between pins during assembly to name a few.

11. Unused Input Pins

Input pins of an IC are often connected to the gate of a MOS transistor. The gate has extremely high impedance and extremely low capacitance. If left unconnected, the electric field from the outside can easily charge it. The small charge acquired in this way is enough to produce a significant effect on the conduction through the transistor and cause unexpected operation of the IC. So unless otherwise specified, unused input pins should be connected to the power supply or ground line.

Operational Notes – continued

12. Regarding the Input Pin of the IC

This monolithic IC contains P+ isolation and P substrate layers between adjacent elements in order to keep them isolated. P-N junctions are formed at the intersection of the P layers with the N layers of other elements, creating a parasitic diode or transistor. For example (refer to figure below):

When $GND > Pin A$ and $GND > Pin B$, the P-N junction operates as a parasitic diode.

When $GND > Pin B$, the P-N junction operates as a parasitic transistor.

Parasitic diodes inevitably occur in the structure of the IC. The operation of parasitic diodes can result in mutual interference among circuits, operational faults, or physical damage. Therefore, conditions that cause these diodes to operate, such as applying a voltage lower than the GND voltage to an input pin (and thus to the P substrate) should be avoided.

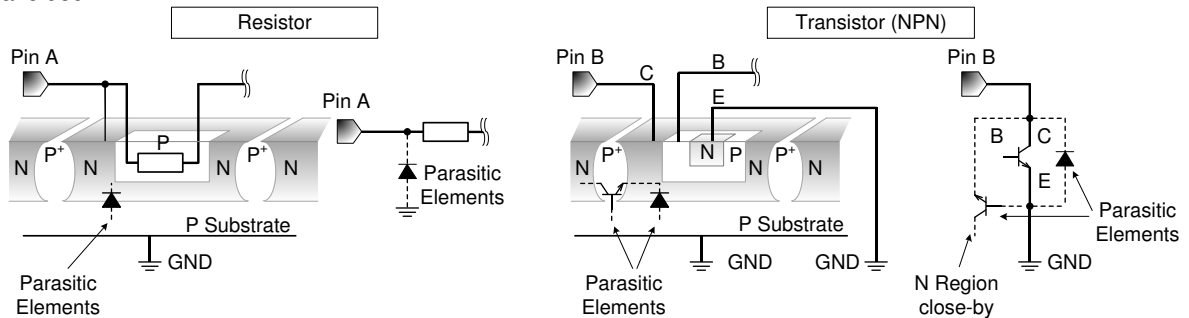

Figure 11. Example of monolithic IC structure

13. Thermal Shutdown Circuit(TSD)

This IC has a built-in thermal shutdown circuit that prevents heat damage to the IC. Normal operation should always be within the IC's power dissipation rating. If however the rating is exceeded for a continued period, the junction temperature (T_j) will exceed 175°C which will activate the TSD circuit that will turn OFF all output pins. When the T_j falls below the TSD threshold, the circuits are automatically restored to normal operation.

Note that the TSD circuit operates in a situation that exceeds the absolute maximum ratings and therefore, under no circumstances, should the TSD circuit be used in a set design or for any purpose other than protecting the IC from heat damage.

14. Capacitor Across Output and GND

If a large capacitor is connected between the output pin and ground pin, current from the charged capacitor can flow into the output pin and may destroy the IC when the VCC or IN pin is shorted to ground or pulled down to 0V. Use a capacitor smaller than $1000\mu\text{F}$ between output and ground.

15. Output Capacitor

Do not fail to connect a output capacitor to VTT output terminal for stabilization of output voltage. The output capacitor works as a loop gain phase compensator and an output voltage variation reducer in the event of sudden change in load. Insufficient capacitance may cause an oscillation. And if the equivalent series resistance (ESR) of this capacitor is high, the variation in output increases in the event of sudden change in load. It is recommended to connect a $10\mu\text{F}$ or so ceramic capacitor, though it depends on ambient temperature and load conditions. It is therefore requested to carefully check under the actual temperature and load conditions to be applied.

16. Input Capacitors Setting

These input capacitors are used to reduce the output impedance of power supply to be connected to the input terminals (VCC and VTT_IN). Increase in the power supply output impedance may result in oscillation or degradation in ripple rejecting characteristics. It is recommended to use a low temperature coefficient $1\mu\text{F}$ (for VCC) and $10\mu\text{F}$ (for VTT_IN) capacitor, but it depends on the characteristics of the power supply input, and the capacitance and impedance of the pc board wiring pattern. It is therefore requested to carefully check under the actual temperature and load conditions to be applied.

Operational Notes – continued

17. Input Terminals (VCC, VTT_IN and REF)

VCC, VTT_IN and REF terminals of this IC are made up independent one another. To VCC terminal, the UVLO function is provided for malfunction protection. Irrespective of the input order of the inputs terminals, VTT output is activated to provide the output voltage when UVLO voltages reach the threshold voltage while REF voltage reaches the threshold of EN.

18. REF Pin

REF pin controls this IC's status ON or OFF. When REF voltage reaches EN-ON voltage, the output voltage operates.

19. Operating Range

Within the operating range, the operation and function of the circuits are generally guaranteed at an ambient temperature within the range specified. The values specified for electrical characteristics may not be guaranteed, but drastic change may not occur to such characteristics within the operating range.

20. Thermal Shutdown Circuits

This IC incorporates a built-in-thermal shutdown circuit, to prevent the IC from thermal breakdown. In thermal shutdown circuit operation, VTT output to be OFF. The thermal shutdown circuit is originally designed to protect the incorporated IC i so that thermal design needs to be designed below the temperature, which enables to run the thermal shutdown circuits.

- 21.** In the event that a load containing a large inductance component is connected to the output terminal, and generation of back-EMF at the start-up and when output is turned OFF is assumed, it is requested to insert a protection diode.

(Example)

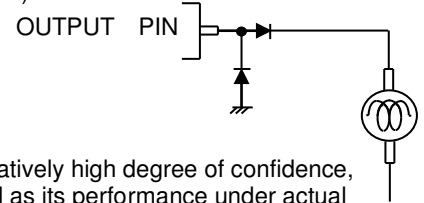
**22. Application Circuit**

Although we can recommend the application circuit contained herein with a relatively high degree of confidence, we ask that you verify all characteristics and specifications of the circuit as well as its performance under actual conditions. Please note that we cannot be held responsible for problems that may arise due to patent infringements or noncompliance with any and all applicable law and regulations.

Ordering Information

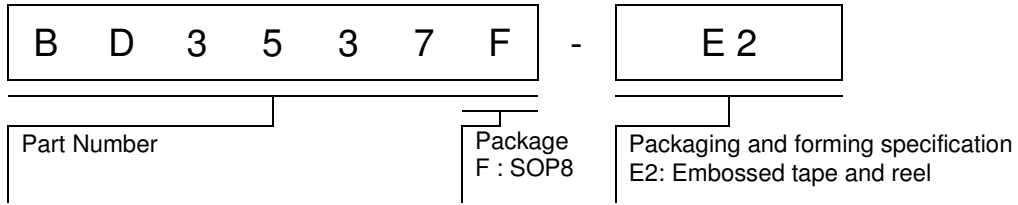

Marking Diagram

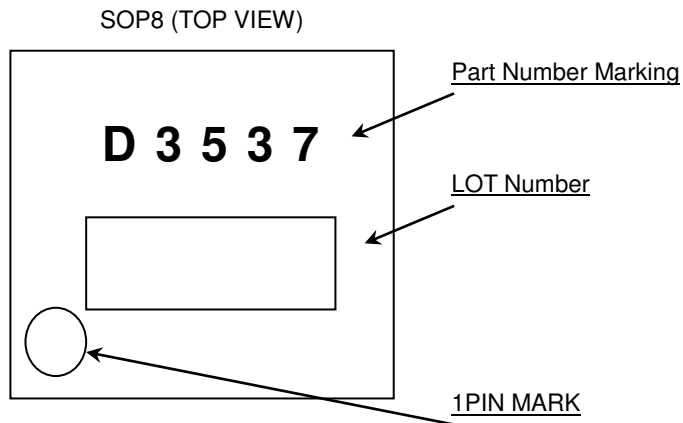

Physical Dimension, Tape and Reel Information

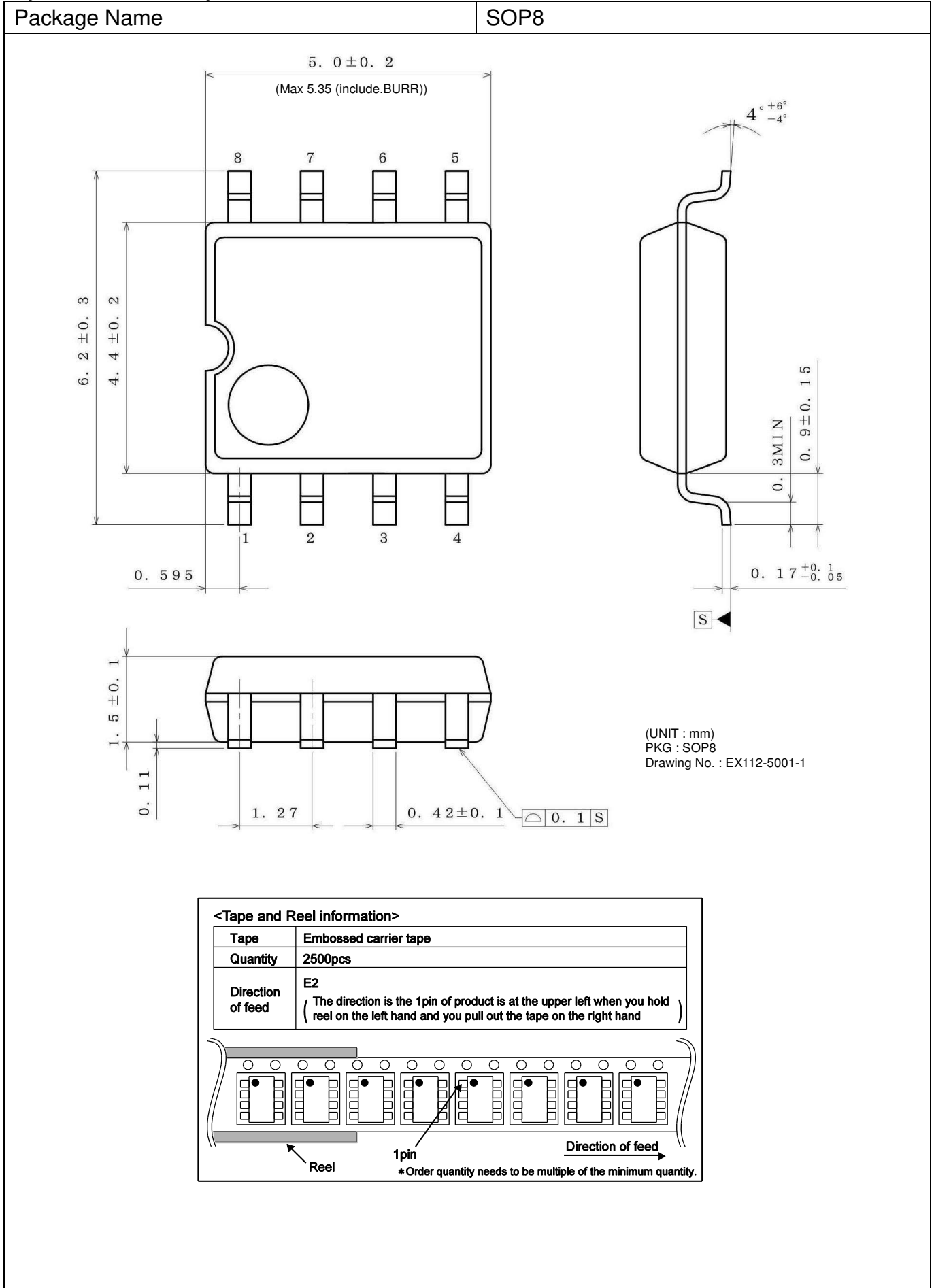

Revision History

Date	Revision	Changes
02.Nov.2015	001	New Release

Notice

Precaution on using ROHM Products

- Our Products are designed and manufactured for application in ordinary electronic equipments (such as AV equipment, OA equipment, telecommunication equipment, home electronic appliances, amusement equipment, etc.). If you intend to use our Products in devices requiring extremely high reliability (such as medical equipment ^(Note 1), transport equipment, traffic equipment, aircraft/spacecraft, nuclear power controllers, fuel controllers, car equipment including car accessories, safety devices, etc.) and whose malfunction or failure may cause loss of human life, bodily injury or serious damage to property ("Specific Applications"), please consult with the ROHM sales representative in advance. Unless otherwise agreed in writing by ROHM in advance, ROHM shall not be in any way responsible or liable for any damages, expenses or losses incurred by you or third parties arising from the use of any ROHM's Products for Specific Applications.

(Note1) Medical Equipment Classification of the Specific Applications

JAPAN	USA	EU	CHINA
CLASS III	CLASS III	CLASS II b	CLASS III
CLASS IV		CLASS III	

- ROHM designs and manufactures its Products subject to strict quality control system. However, semiconductor products can fail or malfunction at a certain rate. Please be sure to implement, at your own responsibilities, adequate safety measures including but not limited to fail-safe design against the physical injury, damage to any property, which a failure or malfunction of our Products may cause. The following are examples of safety measures:
 - Installation of protection circuits or other protective devices to improve system safety
 - Installation of redundant circuits to reduce the impact of single or multiple circuit failure
- Our Products are designed and manufactured for use under standard conditions and not under any special or extraordinary environments or conditions, as exemplified below. Accordingly, ROHM shall not be in any way responsible or liable for any damages, expenses or losses arising from the use of any ROHM's Products under any special or extraordinary environments or conditions. If you intend to use our Products under any special or extraordinary environments or conditions (as exemplified below), your independent verification and confirmation of product performance, reliability, etc. prior to use, must be necessary:
 - Use of our Products in any types of liquid, including water, oils, chemicals, and organic solvents
 - Use of our Products outdoors or in places where the Products are exposed to direct sunlight or dust
 - Use of our Products in places where the Products are exposed to sea wind or corrosive gases, including Cl₂, H₂S, NH₃, SO₂, and NO₂
 - Use of our Products in places where the Products are exposed to static electricity or electromagnetic waves
 - Use of our Products in proximity to heat-producing components, plastic cords, or other flammable items
 - Sealing or coating our Products with resin or other coating materials
 - Use of our Products without cleaning residue of flux (even if you use no-clean type fluxes, cleaning residue of flux is recommended); or Washing our Products by using water or water-soluble cleaning agents for cleaning residue after soldering
 - Use of the Products in places subject to dew condensation
- The Products are not subject to radiation-proof design.
- Please verify and confirm characteristics of the final or mounted products in using the Products.
- In particular, if a transient load (a large amount of load applied in a short period of time, such as pulse. is applied, confirmation of performance characteristics after on-board mounting is strongly recommended. Avoid applying power exceeding normal rated power; exceeding the power rating under steady-state loading condition may negatively affect product performance and reliability.
- De-rate Power Dissipation depending on ambient temperature. When used in sealed area, confirm that it is the use in the range that does not exceed the maximum junction temperature.
- Confirm that operation temperature is within the specified range described in the product specification.
- ROHM shall not be in any way responsible or liable for failure induced under deviant condition from what is defined in this document.

Precaution for Mounting / Circuit board design

- When a highly active halogenous (chlorine, bromine, etc.) flux is used, the residue of flux may negatively affect product performance and reliability.
- In principle, the reflow soldering method must be used on a surface-mount products, the flow soldering method must be used on a through hole mount products. If the flow soldering method is preferred on a surface-mount products, please consult with the ROHM representative in advance.

For details, please refer to ROHM Mounting specification

Precautions Regarding Application Examples and External Circuits

1. If change is made to the constant of an external circuit, please allow a sufficient margin considering variations of the characteristics of the Products and external components, including transient characteristics, as well as static characteristics.
2. You agree that application notes, reference designs, and associated data and information contained in this document are presented only as guidance for Products use. Therefore, in case you use such information, you are solely responsible for it and you must exercise your own independent verification and judgment in the use of such information contained in this document. ROHM shall not be in any way responsible or liable for any damages, expenses or losses incurred by you or third parties arising from the use of such information.

Precaution for Electrostatic

This Product is electrostatic sensitive product, which may be damaged due to electrostatic discharge. Please take proper caution in your manufacturing process and storage so that voltage exceeding the Products maximum rating will not be applied to Products. Please take special care under dry condition (e.g. Grounding of human body / equipment / solder iron, isolation from charged objects, setting of Ionizer, friction prevention and temperature / humidity control).

Precaution for Storage / Transportation

1. Product performance and soldered connections may deteriorate if the Products are stored in the places where:
 - [a] the Products are exposed to sea winds or corrosive gases, including Cl₂, H₂S, NH₃, SO₂, and NO₂
 - [b] the temperature or humidity exceeds those recommended by ROHM
 - [c] the Products are exposed to direct sunshine or condensation
 - [d] the Products are exposed to high Electrostatic
2. Even under ROHM recommended storage condition, solderability of products out of recommended storage time period may be degraded. It is strongly recommended to confirm solderability before using Products of which storage time is exceeding the recommended storage time period.
3. Store / transport cartons in the correct direction, which is indicated on a carton with a symbol. Otherwise bent leads may occur due to excessive stress applied when dropping of a carton.
4. Use Products within the specified time after opening a humidity barrier bag. Baking is required before using Products of which storage time is exceeding the recommended storage time period.

Precaution for Product Label

QR code printed on ROHM Products label is for ROHM's internal use only.

Precaution for Disposition

When disposing Products please dispose them properly using an authorized industry waste company.

Precaution for Foreign Exchange and Foreign Trade act

Since concerned goods might be fallen under listed items of export control prescribed by Foreign exchange and Foreign trade act, please consult with ROHM in case of export.

Precaution Regarding Intellectual Property Rights

1. All information and data including but not limited to application example contained in this document is for reference only. ROHM does not warrant that foregoing information or data will not infringe any intellectual property rights or any other rights of any third party regarding such information or data.
2. ROHM shall not have any obligations where the claims, actions or demands arising from the combination of the Products with other articles such as components, circuits, systems or external equipment (including software).
3. No license, expressly or implied, is granted hereby under any intellectual property rights or other rights of ROHM or any third parties with respect to the Products or the information contained in this document. Provided, however, that ROHM will not assert its intellectual property rights or other rights against you or your customers to the extent necessary to manufacture or sell products containing the Products, subject to the terms and conditions herein.

Other Precaution

1. This document may not be reprinted or reproduced, in whole or in part, without prior written consent of ROHM.
2. The Products may not be disassembled, converted, modified, reproduced or otherwise changed without prior written consent of ROHM.
3. In no event shall you use in any way whatsoever the Products and the related technical information contained in the Products or this document for any military purposes, including but not limited to, the development of mass-destruction weapons.
4. The proper names of companies or products described in this document are trademarks or registered trademarks of ROHM, its affiliated companies or third parties.

General Precaution

1. Before you use our Products, you are requested to carefully read this document and fully understand its contents. ROHM shall not be in any way responsible or liable for failure, malfunction or accident arising from the use of any ROHM's Products against warning, caution or note contained in this document.
2. All information contained in this document is current as of the issuing date and subject to change without any prior notice. Before purchasing or using ROHM's Products, please confirm the latest information with a ROHM sales representative.
3. The information contained in this document is provided on an "as is" basis and ROHM does not warrant that all information contained in this document is accurate and/or error-free. ROHM shall not be in any way responsible or liable for any damages, expenses or losses incurred by you or third parties resulting from inaccuracy or errors of or concerning such information.