

Mono and Colour QSIF Digital Video CMOS Image Sensors

PRELIMINARY RELEASE

The VV5301 and VV6301 are highly integrated digital output imaging devices based on STMicroelectronics's unique CMOS sensor technology. Both of these sensors require minimal support circuitry and provide an ideal low cost imaging solution.

VV5301 (monochrome) and VV6301 (colourised) produce digital video output. The video streams from both devices contain embedded control data that can be used to enable frame grabbing applications.

The pixel array of the VV6301 has colour filters forming a Bayer colour pattern. This sensor requires software to perform colour processing to allow an image to be displayed on a PC.

The sensor can perform automatic black calibration to remove voltage offsets in the video signal path that lead to offsets in the output image. These offsets are removed using 2 Digital to Analogue Convertors (DACs). The automatic black calibration algorithm monitors the average level of the sensor black pixels and adjusts the input level to the 2 DACs to remove the offset.

A 2 wire serial interface allows the sensor to be reconfigured if required.

Functional block diagram

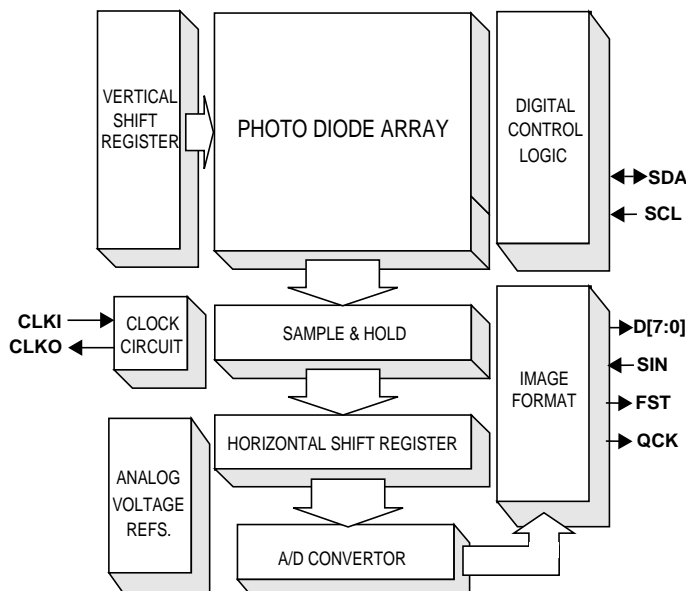

Key Features

- QSIF resolution sensor
- Automatic exposure/gain control
- Multiple digital output formats available
- I2C interface for sensor control
- Integrated 8bit ADC
- On board voltage regulator
- Automatic Black Calibration
- Variable frame rate
- Reduced flicker operating modes

Application Areas

- Toys
- Automotive systems
- Intelligent Imaging sensors

Specifications

Maximum pixel resolution	164 x 124
Effective image size after colour processing	160 x 120
Pixel size	12.0µm x 12.0µm
Array size	1.92mm x 1.44mm
Exposure control	Automatic (range 25000:1)
Analogue gain	+18dB
Signal/Noise ratio	36dB
Supply voltage	5V DC +/- 5%
Supply current VV5301-VV6301	2.9mA (standby) 14.6mA (active)
Operating temperature (ambient)	0°C - 40°C (for extended temperature information please contact STMicroelectronics)
Package type	48BGA

Preliminary Release

Table of Contents

1.	Introduction	4
1.1	Overview	4
1.2	Exposure, Clock Division and Gain Control	4
1.3	Digital Interface	4
2.	Operating Modes	6
2.1	Video Timing	6
2.2	Pixel Array.....	6
2.3	System Clock Generation	9
2.4	Calculating Sensor Framerate	9
3.	Auto Black Calibration.....	11
4.	Exposure Control	12
3.	Auto Black Calibration.....	11
4.	Exposure Control	12
4.1	Calculating Exposure Period.....	12
4.2	Automatic Exposure Control	12
4.3	Updating Exposure, Gain and Clock Division Settings	12
4.4	Clock Control	12
4.5	Gain Setting	13
5.	Timed Serial Interface Parameters	14
5.1	Listing and Categorizing the Parameters.....	14
5.2	Timed Parameter Update Points.....	14
6.	Digital Video Interface Format	15
6.1	Embedded control data	15
6.2	8-Wire Parallel Mode	17
6.3	4-Wire Parallel Mode	17
6.4	Video Frame Composition	18
6.5	Qualifying the Output Data.....	22
7.	Serial Control Bus	26
7.1	General Description	26
7.2	Serial Communication Protocol.....	26
7.3	Data Format.....	26
7.4	Message Interpretation	27
7.5	The Programmers Model	28
7.6	Types of messages.....	38
7.7	Serial Interface Timing	40
8.	Detailed AC/DC Specification.....	42

8.1	VV5301/VV6301 AC/DC Specification	42
8.2	VV5301/VV6301 Power Consumption	42
8.3	Digital Input Pad Pull-up and Pull-down Resistors.....	42
9.	Pinout and Pin Descriptions	43
10.	VV5301/VV6301 Recommended Reference Design.....	45
11.	Package Details (48 pin BGA (VV5301/VV6301))	46
12.	Evaluation kits (EVK's)	47
13.	Ordering Details	48

VV5301 & VV6301

1. Introduction

1.1 Overview

VV5301/VV6301 is a SIF format CMOS image sensor. The VV5301 sensor is a monochrome device and the VV6301 is the coloured variant.

Important: The sensors' output video data stream only contains raw data. A microprocessor and supporting software are required to generate a video waveform that can be displayed on a VDU

Mode	Input Clock (MHz) ^{Note}	System Clock Divisor	Image Size	Line Time (μ s)	Lines per Frame	Frame Rate (fps)
QSIF - 25 fps	14.318	1	164 x 124	271.502	147	25.06
QCIF - 30 fps	17.73	1	164 x 124	227.36	147	29.92

VV5301/VV6301 have an on-board 8bit ADC, this limits the number of components required to form a complete digital imaging system.

The VV5301/VV6301 sensor will output an image size of 164 x 124. This is an oversized QSIF image. The extra pixels that form the 2 pixel deep border that surrounds the true QSIF image are made available to the external colour processing algorithm.

1.2 Exposure, Clock Division and Gain Control

VV5301/VV6301 have an internal automatic exposure/gain control algorithm. This algorithm can be disabled allowing the user to externally control the exposure. The externally calculated exposure, clock division and gain control settings would then be written to the sensor via the I2C interface.

1.3 Digital Interface

VV5301/VV6301 have a flexible digital interface, the main components of which are listed below:

1. A tri-stateable 8-wire data bus (D[7:0]) for sending both video data and embedded timing references.
2. 4-wire and 8-wire data bus alternatives available.
3. A data qualification clock, QCK, which can be programmable via the serial interface to behave in a number of different ways (Tri-stateable).
4. A line start signal, LST (Tri-stateable).
5. A frame start signal, FST (Tri-stateable).
6. OEB tri-states all 5 data bus lines, D[4:0], the qualification clock, QCK and FST.
7. The ability to synchronise the operation of multiple cameras (sensor produces a synchronisation out pulse, SNO).
8. A 2-wire serial interface (SDA,SCL) for controlling and setting up the device.

1.3.1 Digital Data Bus

Along with the pixel data, codes representing the start and end of fields and the start and end of lines are embedded within the video data stream to allow a co-processor to synchronise with video data the camera module is generating Section 6 defines the format for the output video data stream.

1.3.2 Frame Grabber Control Signals

To complement the embedded control sequences the data qualification clock (QCK) and the field start signal (FST) signals can be independently set-up as follows:

1. Disabled
2. Free-running.
3. Qualify only the control sequences and the pixel data.
4. Qualify the pixel data only

1.3.3 2-wire Serial Interface

The 2-wire serial interface provides complete control over sensor setup and operation. Two serial interface broadcast addresses are supported. One allows all sensors to be written to in parallel while the other allows all sensors and co-processors to be written to in parallel.

Section 7. defines the serial interface communications protocol and the register map of all the locations which can be accessed via the serial interface.

1.4 Other Features

1.4.1 Tristating Digital Outputs

The QCK, FST and Databus[7:0] pins can be tristated. The QCK pin can be independently tristated by driving the QCKTRI pin low. The QCK, FST and upper nibble of the Databus can also be tristated via a serial register control bit, see register[116] for more details. The lower nibble of the Databus can also be independently tristated using a different control bit in register[116].

1.4.2 Synchronising Video Timing

The video timing logic in VV5301/VV6301 can be synchronised, i.e. reset to the beginning of a timing field, by an external pin, SIN. This pin is normally low. To enable the synchronising feature the user must drive the pin high for a number of clock periods, c.10 CLKI periods, then drive it low again. This synchronisation should only be done every other field as the sensor has a 2 field repeat cycle requirement for the video timing. If the SIN pin was asserted every field the exposure controller and application of new external exposure and gain settings would not operate correctly.

1.4.3 Pixel Hold Feature

The HPIX signal can be used to freeze the internal ADC, forcing the sensor to stop converting new pixel values. If the HPIX is driven high then the ADC will maintain the currently converted pixel value. This feature is intended to function as an external pixel defect correction system, albeit a ver basic example.

2. Operating Modes

2.1 Video Timing

The video format mode on power-up is QSIF 30fps by default, although a 25fps mode can also be selected, see serial register[17], bit 6. The number of active video lines in each mode is the same (124) for both the QSIF modes. The slower frame rate (25 fps) is implemented by simply extending the line period from 203 pixel periods to 301 pixel periods.

Table 1 details the setup for each of the video timing modes.

Video Mode	Clock (MHz)	System Clock Divisor	Video Data	Line Length	Field Length	Output Mode
QSIF (30fps)	14.318	1	164 x 124	203	147	4-wire
QSIF (25fps)	17.73	1	164 x 124	301	147	4-wire

Table 1 : Video Timing Modes

2.2 Pixel Array

The physical pixel array is 168 x 124 pixels. The pixel size is 12.0 µm by 12.0 µm. The output video image size is 164 x 124 pixels. The border pixels from the array are used as a shield from edge effects.

Figure 3 shows how the 164 x 124 is aligned within the bigger 168 x 124 pixel array. Image read-out is flexible. By default the sensor read out is configured to be horizontally 'non-shuffled' non-interlaced raster scan. The horizontally 'shuffled' raster scan order differs from a conventional raster in that the pixels of individual rows are re-ordered, with the even pixels within a row read-out first, followed by the odd pixels. This 'shuffled' read-out within a line, groups pixels of the same colour (according to the Bayer pattern - Figure 1) together, reducing cross talk between the colour channels. The horizontal shuffle option would normally only be selected with the colour sensor variant, VV6301.

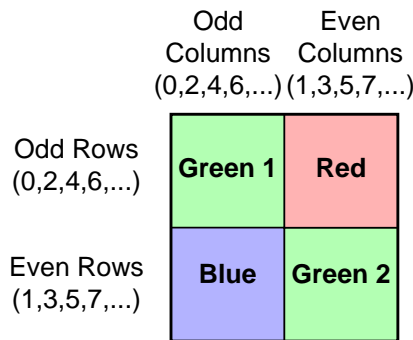
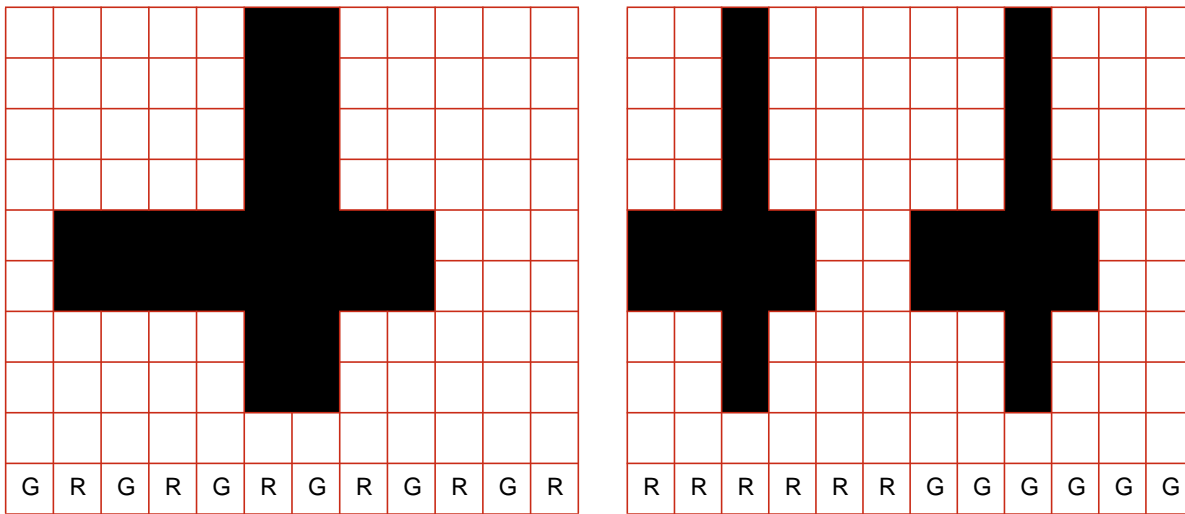

Figure 1 : Bayer Colourisation Pattern (VV6301 only)

Preliminary Release



Where G - Green and R - Red

Figure 2 : Horizontal Shuffle Enabled

1	Green	Red	Green	Red	Green	Red	Green	Red
2	Blue	Green	Blue	Green	Blue	Green	Blue	Green
3	Green	Red	Green	Red	Green	Red	Green	Red
4	Blue	Green	Blue	Green	Blue	Green	Blue	Green
5	Green	Red	Green	Red	Green	Red	Green	Red
6	Blue	Green	Blue	Green	Blue	Green	Blue	Green

Please note the column read out order. If the readout is unshuffled then the readout order is even,odd,even etc. If the readout is shuffled, to avoid colour channel crosstalk, then all the even columns are readout first followed by the odd columns.

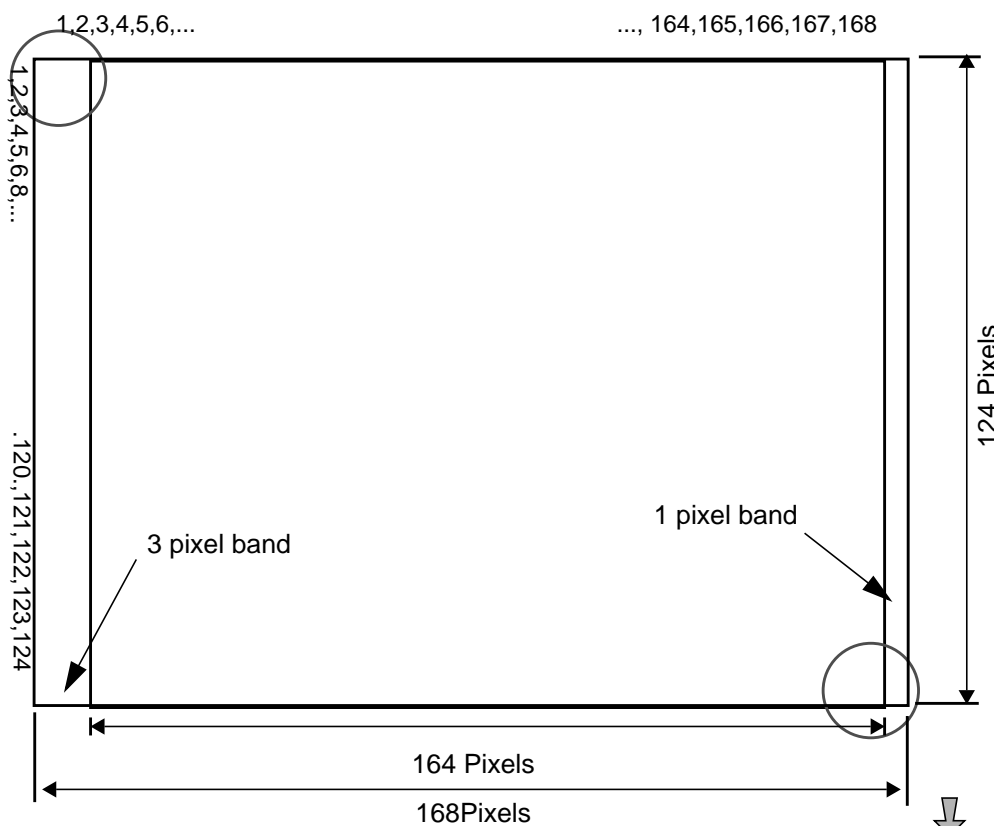

The colour dyes included in this diagram are only applicable to VV6301. The monochrome device VV5301 has exactly the same readout structure and array size as VV6301 - but no colourised pixels

Green	Red	Green	Red	Green	Red	Green	Red	119
Blue	Green	Blue	Green	Blue	Green	Blue	Green	120
Green	Red	Green	Red	Green	Red	Green	Red	121
Blue	Green	Blue	Green	Blue	Green	Blue	Green	122
Green	Red	Green	Red	Green	Red	Green	Red	123
Blue	Green	Blue	Green	Blue	Green	Blue	Green	124
161	162	163	164	165	166	167	168	

Figure 3 : Image Readout Order

Preliminary Release

2.3 System Clock Generation

VV5301/VV6301 generates a system clock when a quartz crystal or ceramic resonator circuit is connected to the CLKI and CKO pins. The device can also be driven directly from an external clock source driving CLKI.

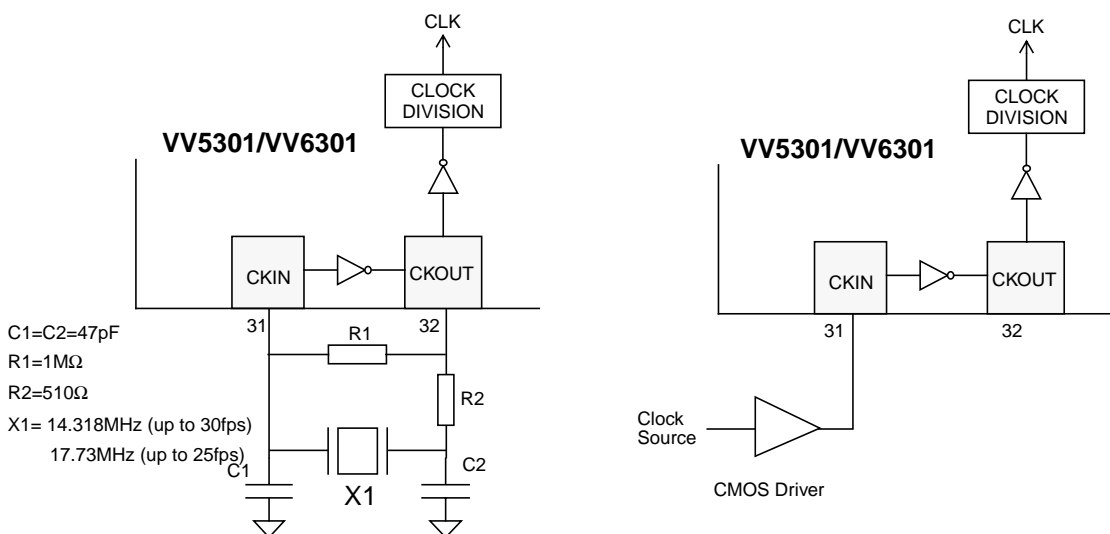

Figure 4 : Camera Clock Source

For greater flexibility the input frequency can be divided by 1, 2, 4 or 8 to select the pixel clock frequency. Two bits in the clock division register in the serial interface select the input clock frequency divisor. The table below gives the different frame rates that can be selected, when CLKI = 14.318MHz, for up to 30frames per second, for each divisor.

CLKI (MHz)	Divisor	Pixel Period (us)	Frame Rate	Comments
14.318	1	1.1175	29.99	default
14.318	2	2.235	15.01	
14.318	4	4.47	7.5	
14.318	8	8.94	3.75	

Table 2 : Clock Division (60Hz Video Mode)

2.4 Calculating Sensor Framerate

The VV5301/VV6301 frame rate depends upon:

- the frequency of the system clock (CLKI)
- the ADC conversion accuracy (8-bit)
- the internal clock divisor selected (1, 2, 4, or 8)
- the output format is a constant 2

User can set their own values for CLKI and also the clock divisor setting. The frame rate is determined as follows

An example is given with a clock input of 14.318MHz, 160 x120 (164 x 124) image format, 8-bit ADC conversion rate and a clock divisor of 2.

1. Determine clock input (CLKI) frequency - 14.318MHz
2. Pixel period = (divisor x conversion factor x output format factor) / CLKI

Clock divisor = 1, 2, 4 or 8.

Conversion factor = 8 for 8-bit ADC accuracy

Output format factor is 2

Example: Pixel period = $(2 \times 8 \times 2) / 14.318\text{MHz} = 2.235\mu\text{s}$

3. Line period = (no. of visible pixels + line overhead) x pixel period

The number of visible pixels per line is 160. The interline pixel period overhead (including the 4 border pixels that can be enabled to qualify extra video information) is mode dependent, 43 pixel periods for 60Hz mode or 141 pixel periods for 50Hz mode.

Example: Line period = $(160 + 43) \times 2.235\mu\text{s} = 453.705\mu\text{s}$

4. Frame period = (no. of visible lines + frame overhead) x line period

For the purposes of calculating the effective frame rate the number of active lines is assumed to be fixed at 120. The frame overhead (which includes the 4 border lines that can be enabled to qualify extra video information) has a constant value of 27 line periods.

Example: Frame period = $(120 + 27) \times 453.705\mu\text{s} = 66.694\text{ms}$

giving a frame rate = $1 / \text{frame period} = 15 \text{ frames per second}$

3. Auto Black Calibration

Black calibration is used to remove voltage offsets that cause shifts in the black level of the video signal. The VV5/6301 is equipped with an automatic function that continually monitors the output black level and calibrates if it has moved out of range. The signal is corrected using two “Black-Cal” DACs, B0 and B1, shown below

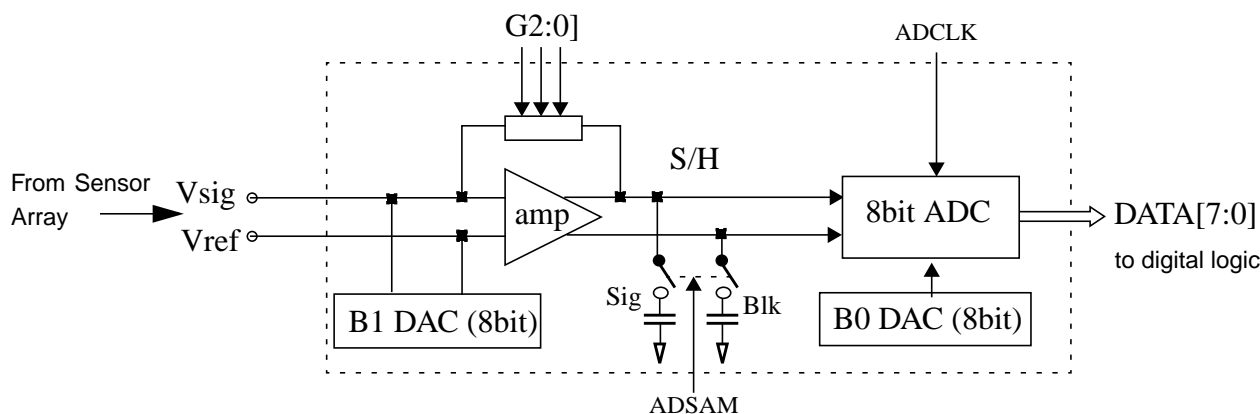

Figure 5 : Block Diagram of Black Calibration System

Black calibration can be split into two stages, **monitor** (1 cycle over 2 lines) and **update** (3 cycles, each cycle takes 2 lines). During the monitor phase the current black level is compared against two threshold values. If the current value falls outside the threshold window then an update cycle is triggered. The update cycle can also be triggered by a change in the gain applied to sensor core or via the serial interface.

3.1 Monitor Procedure

The decision on when to re-calibrate the black level is made during the first cycle through the black reference lines. The decision area for the black monitor is by default the last 16 pixels of the middle 128 pixels of the second designated black line, line 2. However if this set of pixels fail to give a “good” black level then it is possible to use the penultimate group of 16 pixels.

The black reference pixels are summed, averaged and then compared with the monitor window. If the average falls outside the window a flag is then set to force a re-calibration of the DAC values.

3.2 Update

The black calibration update sequence requires three phases and is performed over the remaining black lines at the start of the video field, lines 3 to 8. During the first phase initial B0 DAC calibration is performed. In the second, the B1 DAC is calibrated within the limitation of its step size. In the final phase the black level is fine tuned by re-calibrating the B0 DAC. This is due to the B1 DAC having a relatively coarse step size when high gain is applied.

The two calibration phases for the B0 DAC differ in that the first time it is calibrated it is working on common mode data. During the final phase the B0 DAC is fine-tuned using black reference pixels.

4. Exposure Control

4.1 Calculating Exposure Period

The exposure time, comprising coarse and fine components, for a pixel and the analogue gain are programmable via the serial interface.

The coarse exposure value sets the number of complete lines a pixel exposes for, while the fine exposure sets the number of additional pixel clock cycles a pixel integrates for. The sum of the two gives the overall exposure time for the pixel array.

Exposure Time = ((Coarse setting x Line Period) + (Fine setting)) x (CLKI clock period) x Clock Divider Ratio_{note1}

note1: Clock Divider Ratio = 1/(Basic Clock Division * Optional Pixel Clock Divisor)

4.2 Automatic Exposure Control

With automatic exposure control selected VV5301/VV6301 uses a complex algorithm to automatically set the exposure value for the current scene. When combined with clock control and gain control the VV5301/VV6301 can operate over a very wide range of illumination levels.

4.3 Updating Exposure, Gain and Clock Division Settings

Although the user can write a new exposure, gain or clock division parameter at any point within the field the sensor will only consume these new external values at a certain point. The exception to this behaviour are when the user has selected immediate update of gain. If the user has selected the former then the new gain value will be applied as soon as the serial interface message has completed. The fine and coarse exposure values are always written in a “timed” manner. There are two “update pending” flags available to the user (see Status0 reg[2] for details) that allows the user to detect when the sensor has consumed one of the timed parameters. In the next section of this document we will detail all the timed parameters and describe when they are updated.

It is important to realise that there is a 1 frame latency between a new exposure value being applied to the sensor array and the results of this new exposure value being read-out. The same latency does not exist for the gain value. To ensure that the effect of the new exposure and gain values are coincident the sensor delays the application of the new gain value by approximately one frame relative to the application of the new exposure value.

If the user is using the autoincrement option in the serial interface when writing a new series of exposure/gain and clock division parameters then it is important to ensure that the sensor receives the complete message bunch before updating any of the parameters. It is also important that the timed parameters are updated in the correct order, we will discuss this fully in the next section. If an autoincrement message sequence is in progress but we have reached the point in the field timing where the gain value would normally be updated, we actually inhibit the update. We inhibit the update to ensure that the gain change is not passed to the sensor while a change in the exposure is still pending.

4.4 Clock Control

The system clock can be divided down internally to extend the operating range of VV5301/VV6301 by allowing longer exposure times. The clock divisor options are as follows:

Clock divisor register	Effective clock division
2'b00	1
2'b01	2
2'b10	4
2'b11	8

Table 3 : Available clock division

If the user increases the clock divisor setting then the effective exposure period is also increased.

4.5 Gain Setting

An external gain value can be written to the sensor as follows.

Gain binary code	Effective system gain
000	1.000
001	2.000
010	1.333
011	4.000
100	1.143
101	2.667
110	1.600
111	8.000

Table 4 : Gain settings

If the image is too dark and the exposure is already close to its maximum the automatic exposure algorithm will attempt to use extra steps of gain to improve the image brightness. Each change applied by the internal algorithm will double the current value. To compensate for this increase in gain the current exposure is set to half of the maximum value. This should ensure that the user will not be aware of a step change in the scene brightness.

Similarly if the image is too bright and the integration period is short then gain will be reduced by one step (i.e. divide by two). As before, the exposure value is set to half the maximum integration period. The exposure controller can then adjust the exposure value as necessary to provide a correctly exposed image.

If the user disables the automatic exposure/gain controller then the extra gain settings detailed in Table 4 above are available.

5. Timed Serial Interface Parameters

The previous section, Exposure Control, introduced the concept of a “timed parameter”, that is information that is written via the serial interface but will not be used immediately by the sensor, rather there will be a delay before the information is passed to the internal registers (referred to as the working registers) from the serial interface registers (referred to as the shadow registers). It is the contents of the working registers that will determine sensor behaviour.

5.1 Listing and Categorizing the Parameters

The timed parameters are split into 2 categories as follows:

- fine and coarse exposure
- gain

There is a “pending” flag for each of the above categories. These flags are stored in Status0 Register[2] in bits [0] and [2]. If one of the flags is high this indicates that the working register/s controlled by that flag have yet to be updated from the according shadow register/s. This feedback information could be useful if a user is, for example, attempting to write an external exposure controller. The status of the pending flags allows accurate timing of the serial interface communications.

5.1.1 Fine and Coarse Exposure

The exposure category comprises registers[32,33] and [34,35].

5.1.2 Gain

The gain category simply comprises register[36].

5.2 Timed Parameter Update Points

The timed parameter categories are updated as follows:

note: We refer to odd and even fields in the table below. Each field is identical in length but we have to be able to differentiate between fields to enable correct updating of register parameters.

Timed parameter category	Updated point
fine and coarse exposure	During the interline period between the last line of the odd field and the first line of the even field.
gain	During the interline period between line 143 and line 144 in the even field.

Table 5 : Timed Parameter Update Points

If a change in exposure and gain are pending at the same time then the exposure value will be updated first followed by the gain. This will ensure image illumination continuity from field to field.

6. Digital Video Interface Format

The video interface consists of a bidirectional, tri-stateable 5-wire data bus. The nibble transmission is synchronised to the rising edge of the system clock.

Read-out Order	Progressive Scan (Non-interlaced)	
Form of encoding	Uniformly quantised, PCM, 8/10 bits per sample	
Correspondence between video signal levels and quantisation levels:	The internal 10-bit pixel data is clipped to ensure that 0 _H and 3FF _H (5 Wire) or FF _H (4/8 Wire) values do not occur when pixel data is being output on the data bus.	
	VV5301/VV6301	
	8-Bit Data	
	Pixel Values	1 to 254
Black Level	16	

Digital video data is 8 bits per sample in VV5301 and VV6301. The data can be transmitted in the following ways:

- A single 8 bit byte over 8 output wires_{note}.
- A series pair of 4-bit nibbles, most significant nibble first, on 4 wires.

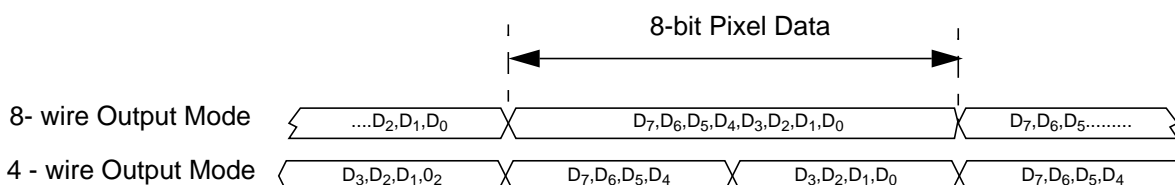

Figure 6 : Output Modes

6.1 Embedded control data

To distinguish the control data from the sampled video data all control data is encapsulated in embedded control sequences. These are 6 bytes long and include a combined escape/sync character sequence, 1 control byte (the 'command byte') and 2 bytes of supplementary data.

To minimise the susceptibility of the embedded control data to random bit errors redundant coding techniques have been used to allow single bit errors in the embedded control words to be corrected. However, more serious corruption of control words or the corruption of escape/sync characters cannot be tolerated without loss of sync to the data stream. To ensure that a loss of sync is detected a simple set of rules has been devised. The four exceptions to the rules are outlined below:

1. Data containing a command word that has two bit errors.
2. Data containing two 'end of line' codes that are not separated by a 'start of line' code.
3. Data preceding an 'end of field' code before a start of frame' code has been received.
4. Data containing line that do not have sequential line numbers (excluding the 'end of field' line).

If the receiving software or hardware detects one of these violations then it should abandon the current field of video

6.1.1 The combined escape and sync character

Each embedded control sequence begins with a combined escape and sync character that is made up of three words. The first two of these are FF_H FF_H- constituting two words that are illegal in normal data. The next word is 00_H - guaranteeing a clear

signal transition that allows a video processor to determine the position of the word boundaries in the serial stream of nibbles. Combined escape and sync characters are always followed by a command byte - making up the four byte minimum embedded control sequence.

6.1.2 The command word

The byte that follows the combined escape/sync characters defines the type of embedded control data. Three of the 8 bits are used to carry the control information, four are 'parity bits' that allow the video processor to detect and correct a certain level of errors in the transmission of the command words, the remaining bit is always set to 1 to ensure that the command word never has the value 00_H. The coding scheme used allows the correction of single bit errors (in the 8-bit sequence) and the detection of 2 bit errors. The even parity bits are based on the following relationships:

1. An even number of ones in the 4-bit sequence (C₂, C₁, C₀ and P₀).
2. An even number of ones in the 3-bit sequence (C₂, C₁, P₁).
3. An even number of ones in the 3-bit sequence (C₂, C₀, P₂).
4. An even number of ones in the 3-bit sequence (C₁, C₀, P₃).

Table 7 shows how the parity bits maybe used to detect and correct 1-bit errors and detect 2-bit errors.

Line Code	Nibble X _H (1 C ₂ C ₁ C ₀)	Nibble Y _H (P ₃ P ₂ P ₁ P ₀)
End of Line	1000 ₂ (8 _H)	0000 ₂ (0 _H)
Blank Line (BL)	1001 ₂ (9 _H)	1101 ₂ (D _H)
Black line (BK)	1010 ₂ (A _H)	1011 ₂ (B _H)
Visible Line (VL)	1011 ₂ (B _H)	0110 ₂ (6 _H)
Start of Field (SOF)	1100 ₂ (C _H)	0111 ₂ (7 _H)
End of Field (EOF)	1101 ₂ (D _H)	1010 ₂ (A _H)

Table 6 : Embedded Line Codes (for 4 wire output mode)

Parity Checks				Comment
P ₃	P ₂	P ₁	P ₀	
✓	✓	✓	✓	Code word un-corrupted
✓	✓	✓	✗	P ₀ corrupted, line code OK
✓	✓	✗	✓	P ₁ corrupted, line code OK
✓	✗	✓	✓	P ₂ corrupted, line code OK
✗	✓	✓	✓	P ₃ corrupted, line code OK
✗	✗	✓	✗	C ₀ corrupted, invert sense of C ₀
✗	✓	✗	✗	C ₁ corrupted, invert sense of C ₁
✓	✗	✗	✗	C ₂ corrupted, invert sense of C ₂
All other codes				2-bit error in code word.

Table 7 : Parity Checking

Preliminary Release

6.2 8-Wire Parallel Mode

If this output mode is selected then the 8-bit pixel data is output on pins DATA[7:0]. The data is valid on the falling edge of the pixel qualification clock, QCK.

6.3 4-Wire Parallel Mode

If the 4-Wire parallel mode is selected then a pixel value is output over 2, 4-wire nibbles transmitted over pins DATA[7:4]. A falling edge on QCK will sample a data nibble.

6.4 Video Frame Composition

Each frame of video sequence comprises 2 fields. Each field of data is constructed of the following sequence of data lines.

1. A start of field line
2. A number of black lines
3. A number of blank (or dark) lines
4. A number active video lines
5. An end of field line
6. A number of blank or black lines

Video Format	QSIF	
	On	Off
Extra Black Lines		
1st Field		
Start of Field Line	1	1
Black Lines	8	2
Blanking Lines	2	8
Active Video lines	124	124
Blanking Lines	10	10
End of Field Line	1	1
Blanking Lines	1	1
Total	147	147
2nd Field		
Start of Field Line	1	1
Black Lines	8	2
Blanking Lines	2	8
Active Video lines	124	124
Blanking Lines	10	10
End of Field Line	1	1
Blanking Lines	1	1
Total	147	147

Table 8 : Field and Frame Composition

Each line of data starts with an embedded control sequence that identifies the line type (as outlined in). The control sequence is then followed by two bytes that contain a coded line number. The line number sequences starts with the start-of-frame line at 00_H and increments one per line up until the end-of-frame line. Each line is terminated with an end-of-line embedded control sequence. The line start embedded sequences must be used to recognise visible video lines as a number of null bytes may be inserted between successive data lines.

There are two figures (Figure 7 - Figure 8) on the following pages that show line type field construction.

6.4.1 Blank lines

In addition to padding between data lines, actual blank data lines may appear in the positions indicated above. These lines begin

Preliminary Release

with start-of-blank-line embedded control sequences and are constructed identically to active video lines except that they will contain only blank bytes, 07_H, (expressed as 01C_H in 10bit form).

6.4.2 Black line timing

The black lines (which are used for black calibration) are identical in structure to valid video lines except that they begin with a start-of-black line code and contain information from the sensor black lines.

The user can opt to enable extra black lines up to a maximum of 8. The black calibration algorithm always has access to the data contained within these lines whether they are externally enabled or not.

Preliminary Release

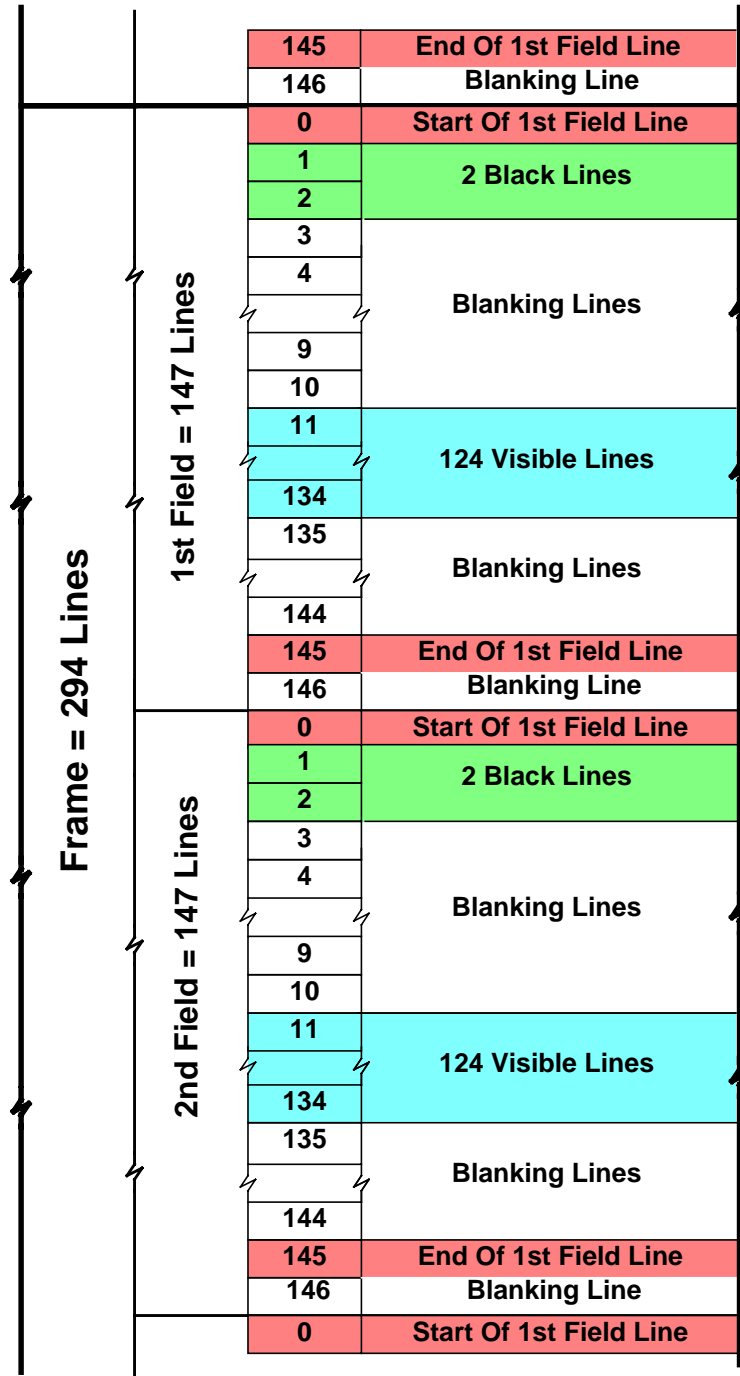
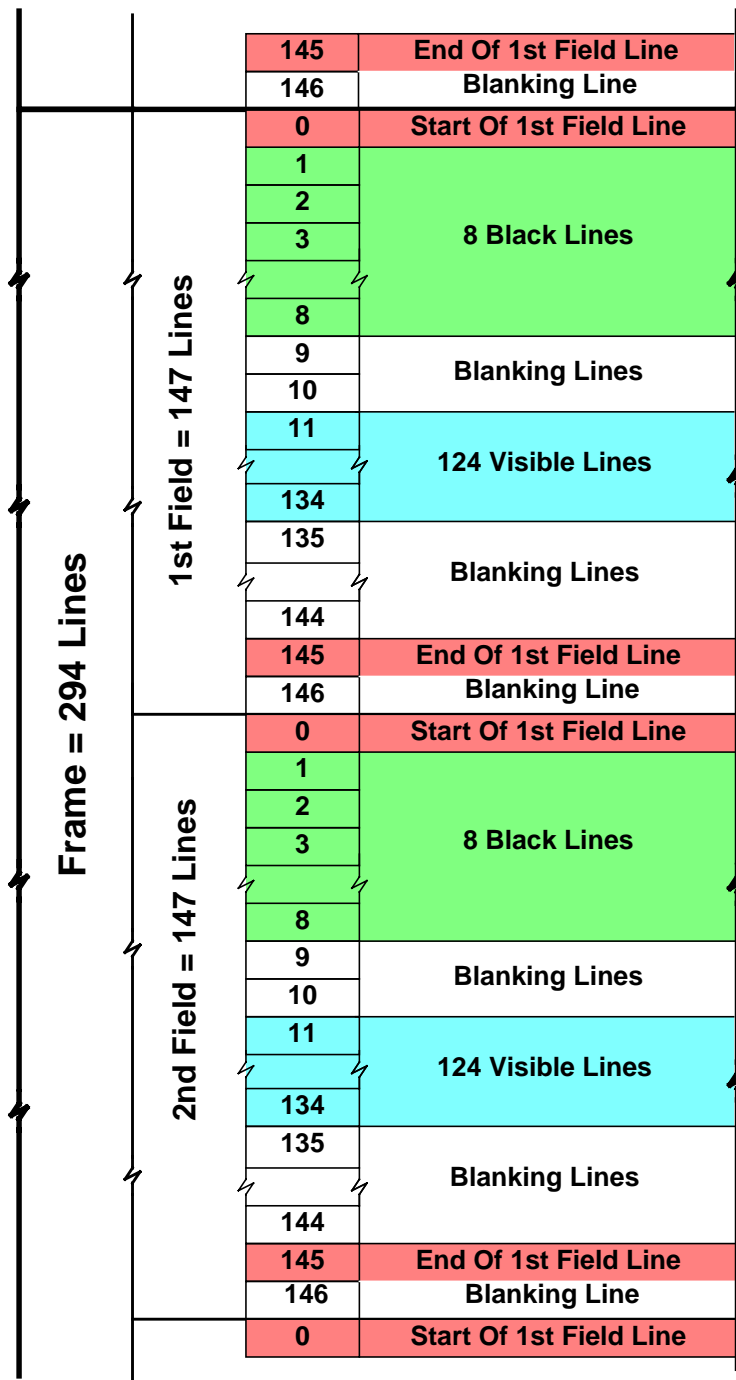

Figure 7 : Field and Frame Formats - Extra Black Lines Off



Preliminary Release

Figure 8 : Field and Frame Formats - Extra Black Lines On

6.5 Qualifying the Output Data

Data is output from VV5301/VV6301 in a continuous stream. By utilizing signals, like FST, and key events, like the start of a line or the end of line, the user can sample and display the image data. QCK is used to sample the data, as described in the previous section.

Different periods of the frame can be qualified by QCK. The options, which are selected via setup register4 in the serial interface, are as follows:

1. QCK disabled, no data qualified (default)
2. QCK free running, all data qualified
3. QCK qualifies image data only, to include data on black lines currently enabled
4. QCK qualifies embedded control sequences as well as image data. The status line data is also qualified with this option.

6.5.3 Frame Start Signal, FST

There are 3 modes of operation for the FST pin programmable via the serial interface:

1. FST disabled, (default).
2. FST enabled, qualifies
3. Shutter/Electronic Flash Synchronisation Signal - FST rises at the start of the video data in the first black/blank line after the EOF line and falls at the end of data in the SOF line.

The FST output is tri-stated either when OEB is driven high or via the appropriate control bit in the serial interface, (see data_format register[22]).

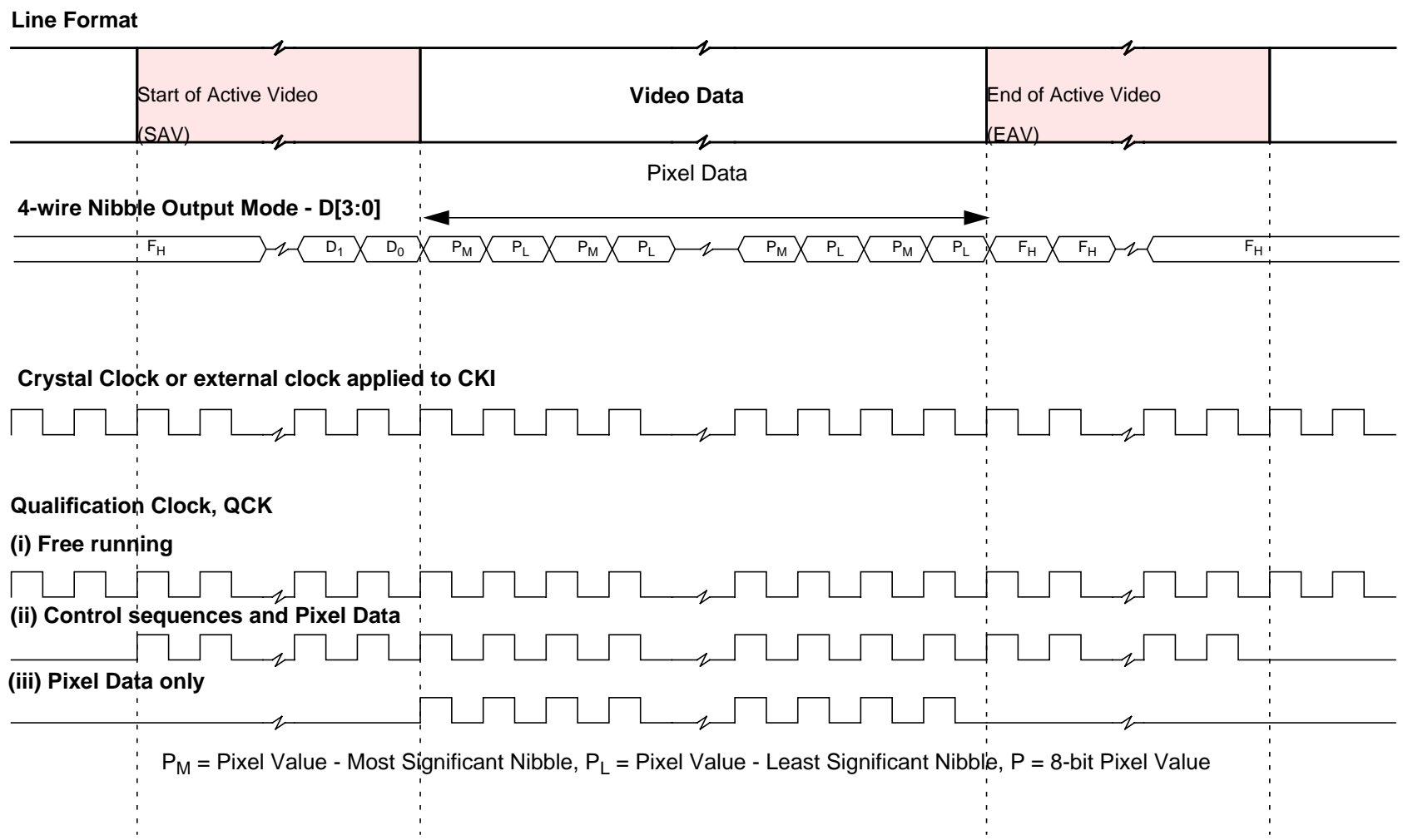

Figure 9 : Qualification of Output Data (Border Rows and Columns Enabled).

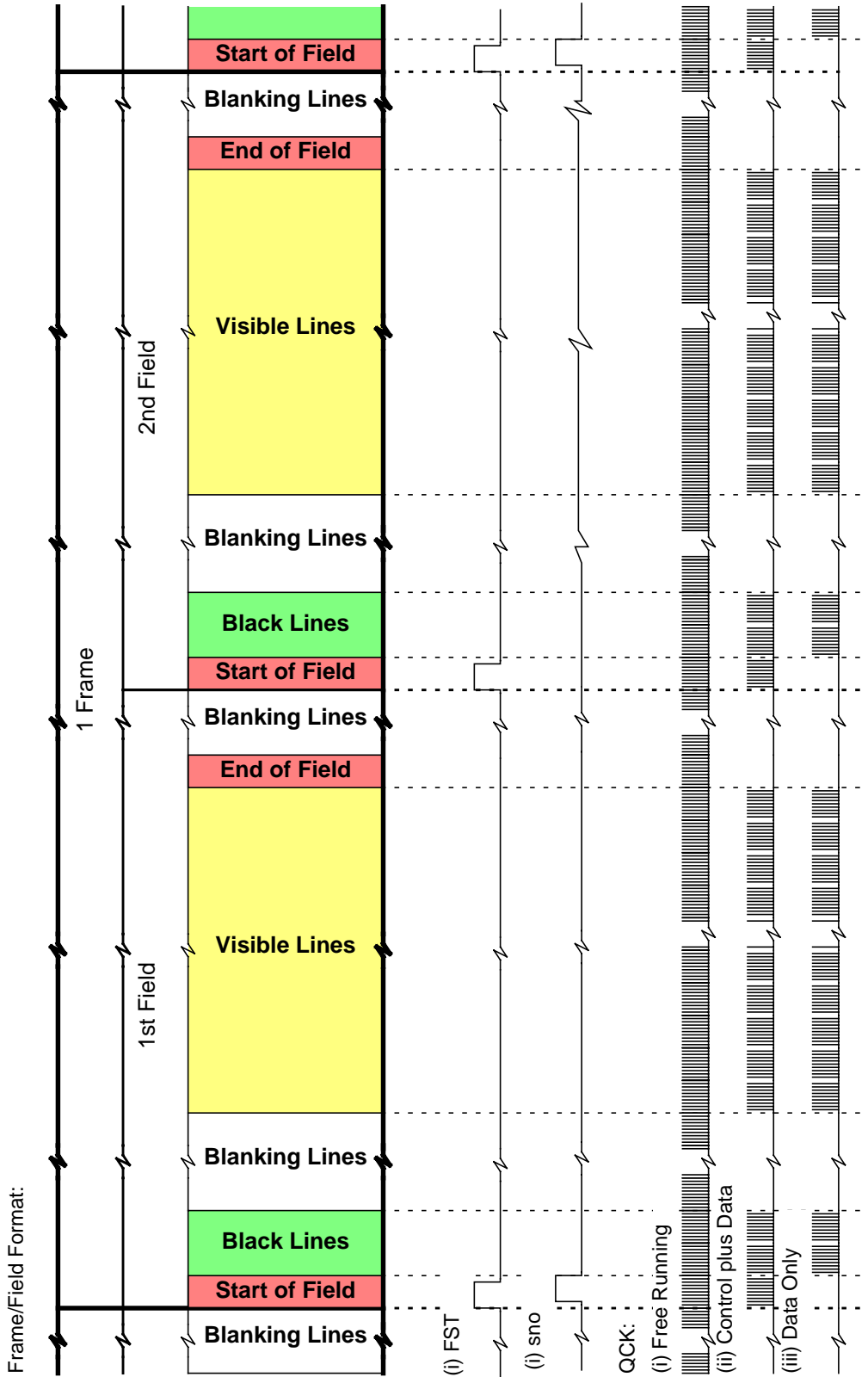

Figure 10 : Frame/Field Level Timings for FST and QCK.

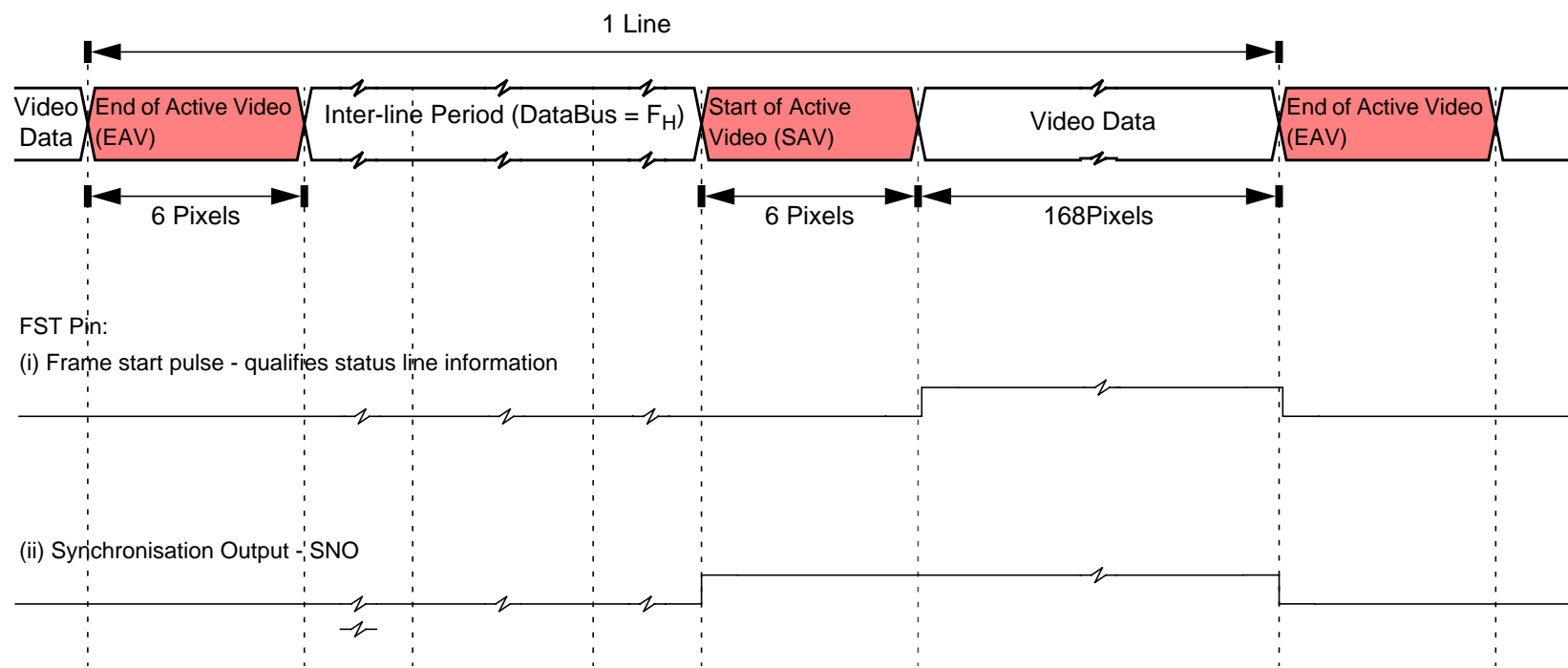

Figure 11 : Line Level Timings for FST.

7. Serial Control Bus

7.1 General Description

Writing configuration information to the video sensor and reading both sensor status and configuration information back from the sensor is performed via the 2-wire serial interface.

Communication using the serial bus centres around a number of registers internal to the video sensor. These registers store sensor status, set-up, exposure and system information. Most of the registers are read/write allowing the receiving equipment to change their contents. Others (such as the chip id) are read only.

The main features of the serial interface include:

- Broad-cast address to ease setting up multiple camera configurations.
- Variable length read/write messages.
- Indexed addressing of information source or destination within the sensor.
- Automatic update of the index after a read or write message.
- Message abort with negative acknowledge from the master.
- Byte oriented messages.

The contents of all internal registers accessible via the serial control bus are encapsulated in each start-of-field line.

7.2 Serial Communication Protocol

The co-processor or host must perform the role of a communications master and the camera acts as either a slave receiver or transmitter. The communication from host to camera takes the form of 8-bit data with a maximum serial clock video processor frequency of up to 100 kHz. Since the serial clock is generated by the bus master it determines the data transfer rate. Data transfer protocol on the bus is illustrated in Figure 12.

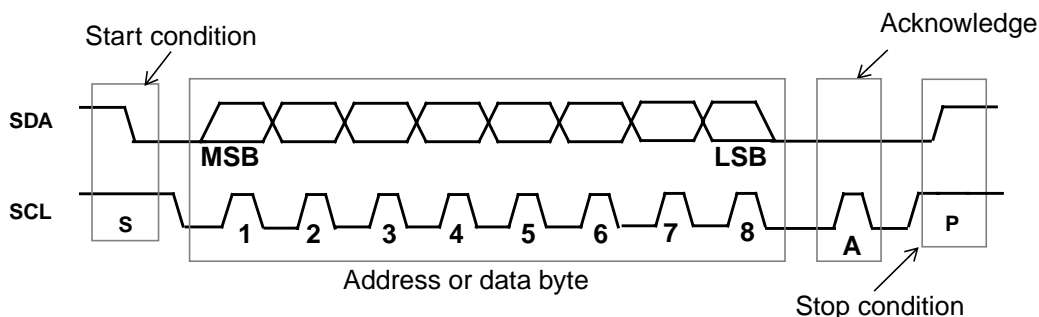

Figure 12 : Serial Interface Data Transfer Protocol

7.3 Data Format

Information is packed in 8-bit packets (bytes) always followed by an acknowledge bit. The internal data is produced by sampling *sda* at a rising edge of *scl*. The external data must be stable during the high period of *scl*. The exceptions to this are *start* (S) or *stop* (P) conditions when *sda* falls or rises respectively, while *scl* is high.

A message contains at least two bytes preceded by a *start* condition and followed by either a *stop* or *repeated start*, (*Sr*) followed by another message.

The first byte contains the device address byte which includes the data direction *read*, (*r*), *~write*, (*~w*), bit. The lsb of the address byte indicates the direction of the message. If the lsb is set high then the master will read data from the slave and if the lsb is reset low then the master will write data to the slave. After the *r*, *~w* bit is sampled, the data direction cannot be changed, until the next address byte with a new *r*, *~w* bit is received.

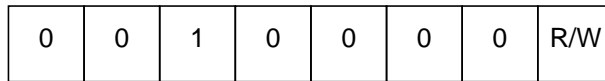

Figure 13 : VV5301/VV6301's Serial Interface Address

The byte following the address byte contains the address of the first data byte (also referred to as the *index*). The serial interface can address up to 128, byte registers. If the msb of the second byte is set the automatic increment feature of the address index is selected.

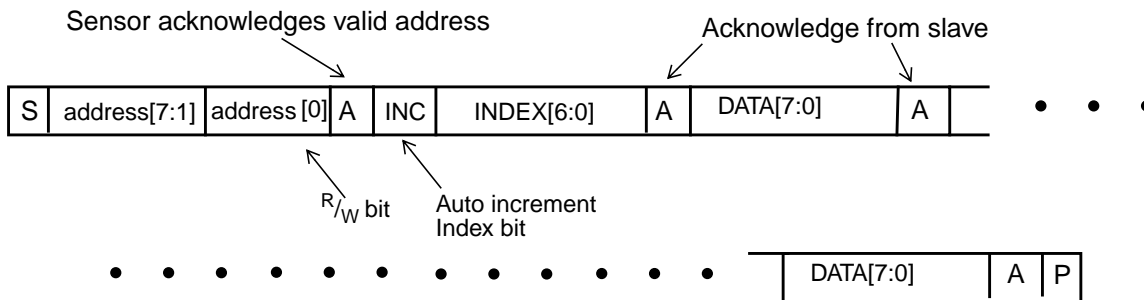

Figure 14 : Serial Interface Data Format

7.4 Message Interpretation

All serial interface communications with the sensor must begin with a *start* condition. If the *start* condition is followed by a valid address byte then further communications can take place. The sensor will acknowledge the receipt of a valid address by driving the *sda* wire low. The state of the *read/~write* bit (lsb of the address byte) is stored and the next byte of data, sampled from *sda*, can be interpreted.

During a write sequence the second byte received is an address index and is used to point to one of the internal registers. The msbit of the following byte is the *index auto increment* flag. If this flag is set then the serial interface will automatically increment the index address by one location after each slave acknowledge. The master can therefore send data bytes continuously to the slave until the slave fails to provide an acknowledge or the master terminates the write communication with a *stop* condition or sends a *repeated start*, (*Sr*). If the auto increment feature is used the master does *not* have to send indexes to accompany the data bytes.

As data is received by the slave it is written bit by bit to a serial/parallel register. After each data byte has been received by the slave, an acknowledge is generated, the data is then stored in the internal register addressed by the current index.

During a read message, the current index is read out in the byte following the device address byte. The next byte read from the slave device are the contents of the register addressed by the current index. The contents of this register are then parallel loaded into the serial/parallel register and clocked out of the device by *scl*.

At the end of each byte, in both read and write message sequences, an acknowledge is issued by the receiving device. Although VV5301/VV6301 is always considered to be a slave device, it acts as a transmitter when the bus master requests a read from the sensor.

At the end of a sequence of incremental reads or writes, the terminal index value in the register will be one *greater* the last location read from or written to. A subsequent read will use this index to begin retrieving data from the internal registers.

A message can only be terminated by the bus master, either by issuing a stop condition, a repeated start condition or by a negative acknowledge after reading a complete byte during a read operation.

7.5 The Programmers Model

There are 128, 8-bit registers within the camera, accessible by the user via the serial interface. They are grouped according to function with each group occupying a 16-byte page of the location address space. There may be up to eight such groups, although this scheme is purely a conceptual feature and not related to the actual hardware implementation, The primary categories are given below:

- Status Registers (Read Only).
- Setup registers with bit significant functions.
- Exposure parameters that influence output image brightness.
- System functions and analog test bit significant registers.

Any internal register that can be written to can also be read from. There are a number of read only registers that contain device status information, (e.g. design revision details).

Names that end with H or L denote the most or least significant part of the internal register. Note that unused locations in the H byte are packed with zeroes.

STMicroelectronics sensors that include a 2-wire serial interface are designed with a common address space. If a register parameter is unused in a design, but has been allocated an address in the generic design model, the location is referred to as **reserved**. If the user attempts to read from any of these **reserved or unused** locations a default byte will be read back. In VV5301/VV6301 this data is 12_H. A write instruction to a reserved (but unused) location is illegal and would not be successful as the device would not allocate an internal register to the data word contained in the instruction.

A detailed description of each register follows. The address indexes are shown as decimal numbers in brackets [...] and are expressed in decimal and **hexadecimal** respectively.

Serial Register Map for VV5301/VV6301						
Index ₁₀	Index ₁₆	Name	Length	R/W	Default	Comments
Status Registers - [0-15]						
0	0	DevH	8	RO	1100 0000 ₂	Reserved
1	1	DevL	8	RO	0001 0010 ₂	
2	2	status0	8	RO	0000 1000 ₂	System status information
3	3	unused		-		
4-6	4-6	unused	8	RO		
7	7	frame_av	8	RO		Average value of pixels in a frame.
8-11	8-B	unused	8	RO		
12-15	C-F	unused		-		
Setup Registers - [16-31]						
16	10	setup0	8	R/W	(27 _H)	Configure the digital logic
17	11	setup1	8	R/W	(70 _H)	Configure the digital logic
18	12	setup2	8	R/W	(1F _H)	Pixel counter reset value
19	13	setup3	8	R/W	(0F _H)	Exposure control modes
20	14	setup4	8	R/W	(00 _H)	FST/QCK options
21-31	15	unused		-		
Exposure Registers - [32-47]						
32	20	unused		-		
33	21	fine	8	R/W	00 _H	Fine exposure initially zero
34	22	unused		-		
35	23	coarse	8	R/W	70 _H	Coarse exposure
36	24	gain	8	R/W	00 _H	Gain value

Serial Register Map for VV5301/VV6301						
Index ₁₀	Index ₁₆	Name	Length	R/W	Default	Comments
37	25	clk_div	8	R/W	00 _H	Clock division
38	26	gn_lim	8	R/W	07 _H	Maximum allowable gain
39	27	tl	8	R/W	55 _H	Lower exposure control threshold.
40	28	tc	8	R/W	64 _H	Centre exposure control threshold.
41	29	th	8	R/W	73 _H	Upper exposure control threshold.
42-47	2A-2F	unused		-		
Colour Registers - [48-79]						
48-79	30-4F	reserved				
Video Timing Registers - [80-103]						
80-103	50-67	reserved				
Text Overlay Registers - [104-107]						
104-107	68-6B	reserved				
Serial Interface Autoload Registers - [108-111]						
108-111	6C-6F	reserved				
System Registers - [112-127]						
112	70	bdac	8	R/W		Black Calibration setup
113	71	b0	8	RO		Manual override of Black Calibration DAC register, B0
114	72	b1	8	RO		Manual override of Black Calibration DAC register, B0
115	73	unused				
116	74	tms	8	R/W		Digital comparator threshold
117	75	unused				
118	76	cr0	8	R/W		
119	77	cr1	8	R/W		
120	78	reserved				
120-127	79-7F	unused				

A detailed description of each register follows. The address indexes are shown as binary in brackets.

7.5.1 Status Registers - [0 - 15],[0-F]

[0-1],[0-1]-[0-1],[0-1] - DeviceH and DeviceL

These registers provide read only information that identifies the sensor type that has been coded as a 12bit number and a 4bit mask set revision identifier. The initial mask revision identifier is 0 i.e. 0000₂. As the mask set is upgraded the revision identifier will increase, i.e. the second mask set will be 0001₂ and so on. The device identification number for VVL301 is 301 i.e. 0001 0010 1101₂.

Bit	Function	Default	Comment
7:4	Device type identifier	1101 ₂	Least significant 4bits of 12bit code identifying the chip type.
3:0	Mask set revision identifier	0000 ₂	

Table 9 : [0],[0] - DeviceL

Bits	Function	Default	Comment
7:0	Device type identifier	0001_0010 ₂	Most significant 8bits of 12bit code identifying the chip type.

Table 10 : [1],[1] - DeviceH

[2],[2] - Status0

Bit	Function	Default	Comment
0	Exposure value update pending	0	New exposure setting sent but not yet consumed by the exposure controller
1	Unused	0	
2	Gain value update pending	0	New gain value sent but not yet consumed by the exposure controller
7:4	Unused	0	

Table 11 : [2],[2] - Status0

[7],[7] - [12-15],[E-F] - unused

7.5.2 Setup Registers - [16 - 31],[10-1F]

[16],[10] - Setup 0

Setup 0 register controls some fundamental exposure and output format parameters. Defaults are shown in **bold type**.

Bit	Function	Default	Comment
0	Automatic exposure control. Off/On	1	Enables or disables automatic exposure control. Current exposure value is frozen when disabled.
1	Unused	1	
2	Automatic gain control. Off/On	1	Enables or disables automatic gain control. Current gain value is frozen when disabled.
4:3	Unused	00 ₂	
5	Data format select.	1	0 - 8 wire parallel output 1 - 4 wire parallel output
7:6	Unused	00 ₂	

Table 12 : [16], [10] - Setup0

[17],[11] - Setup1

Setup 1 register controls registers that are less likely to be modified on a regular basis. The user should note that the border pixels/lines can be disabled/enabled independently from the enabling/disabling of the custom analogue horizontal shift register.

Bit	Function	Default	Comment
0	Enable additional black lines (3-8) Off/On	0	If enabled extra black lines are visible at device output
1	Unused	1	
2	Enable horizontal shuffle mode. Off/On	0	The contents of the horizontal shift register are shuffled so that all the even columns then all the odd columns are read out.

Table 13 : [17], [11] - Setup1

Bit	Function	Default	Comment
5:3	Unused	110 ₂	
6	50Hz timing/ 60Hz timing	1	The sensor will produce field rates either suited to 50Hz or 60Hz (default) operating environments.
7	Unused	0	

Table 13 : [17], [11] - Setup1

[19],[13] - Setup3

Bit	Function	Default	Comment
4:0	unused		
6:5	Exposure step size	01	Selects exposure step size. 1/8 for fast but jerky convergence to 1/64 for slow but smooth convergence. Default 1/16. See Table 15 for details
7	Unused	0	

Table 14 : [19],[13] - Setup3

Bit 6	Bit 5	Step size	Comment
0	0	1/8	
0	1	1/16	Default
1	0	1/32	
1	1	1/64	

Table 15 : Exposure step size options

[20],[14] - Setup4

The data output on the serial wire or the 4/8 wire busses can be qualified by an internally generated clock signal, QCK. The QCK function is assigned a dedicated pin, however the FST pin can also output QCK data, if reconfigured. By default, QCK is disabled. The QCK can free run, qualify the embedded coding sequences and the visible data or the visible data only. FST can also be enabled or disabled, default, or alternatively the FST pin can output a timing signal to synchronise several VV5301/VV6301 sensors or finally the FST pin can output the state of the custom analogue block successive approximation ADC output comparator

Bit	Function	Default	Comment
1:0	FST/QCK pin modes	00	See Table 17 below for details
3:2	QCK modes	00	See Table 18 below for details
5:4	unused		
7:6	FST modes	00	See Table 19 below for details

Table 16 : [20],[14] - fg_modes

fg_mode[1:0]		FST pin	QCK pin
0	0	FST	QCK

Table 17 : FST/QCK Pin Selection

fg_mode[1:0]		FST pin	QCK pin
0	1	FST	QCK
1	0	QCK _{note}	QCK
1	1	Invert QCK _{note}	QCK

Table 17 : FST/QCK Pin Selection

note: The FST pin will always output the free running version of QCK (either inverted or normal)

fg_mode[3:2]		QCK state
0	0	Off
0	1	Free Running
1	0	Valid during data and control period of line
1	1	Valid only during data period of line

Table 18 : QCK Modes

fg_mode[7:6]		FST pin
0	0	Off
0	1	Normal behaviour, FST will qualify the visible pixels in the status line
1	0	Synchronisation out pulse, SNO
1	1	Output ADC comparator output, CPO

Table 19 : FST Modes

[21-31],[15-1F] - unused

7.5.3 Exposure Control Registers [32 - 47],[20-2F]

There is a set of parameters that control the time that the sensor pixels are exposed. The parameters are as follows: fine and coarse exposure time, clock division control and finally gain control. The latter parameter does not affect the integration period rather it amplifies the video signal at the output stage of the sensor core. An internal automatic algorithm will, if enabled, continually monitor the pixel output and then, if required, use this data to correct the current exposure.

Manually changing the divisor applied to the incoming crystal clock can alter the effective integration of the sensor. By slowing the internal clock down the integration period can be increased, i.e. halving the pixel clock frequency will double the integration period.

If the user wishes to use the automatic exposure algorithm, the automatic exposure control (controlling *fine* and *coarse* exposure) must be enabled. Additional gain control is optional. It is also possible to change the gain manually via the serial interface even if the exposure is adjusted automatically.

If a user wishes to write an external value to one of the automatic exposure algorithm registers then it is advised that the automatic control for that register be disabled prior to using the serial interface to write the external value.

Note: The external exposure (coarse, fine or gain) values do not take effect immediately. Data from the serial interface is read by the exposure algorithm at the start of a video frame. If the user reads an exposure value via the serial interface then the value reported will be the data as yet unconsumed by the exposure algorithm, because the serial interface logic locally stores all the data written to the sensor.

Between writing the exposure data and the point at which the data is consumed by the exposure algorithm, bit 0 of the status register is set. The gain value is updated a frame later than the coarse and fine exposure parameters. The gain is applied directly

at the video output stage and does not require the long set up time of the coarse and fine exposure settings.

The automatic exposure algorithm uses a set of exposure threshold settings. These thresholds may also be modified by the user to alter the algorithm's performance. The exposure algorithm uses these thresholds in a histogram. The three thresholds divide the histogram into 4 regions, very overexposed, overexposed, underexposed and very underexposed. The pixel data received from the sensor core is compared against the thresholds to determine the accuracy of the current exposure setting. A series of flags are set to describe the outcome of the histogram comparison and the new exposure setting can then be derived.

Each exposure parameter is subject to a maximum setting. The fine exposure setting can be clamped to a fixed value regardless of the decision made by the automatic algorithm. The clamping will occur if the coarse exposure setting exceeds a predetermined value and the clamping has been enabled via the serial interface.

Bit	Function	Default	Comment
7:0	Fine exposure value	0000_0000 ₂ (00 _H)	maximum fine (50Hz mode) = FF _H maximum fine (60Hz mode) = A8 _H

Table 20 : [33],[21] - Fine Exposure Value

Bit	Function	Default	Comment
7:0	Coarse exposure value	0111_0000 ₂ (70 _H)	maximum coarse (50Hz and 60Hz modes) = 91 _H

Table 21 : [34],[22] - Coarse Exposure Value

Bit	Function	Default	Comment
2:0	Gain value	0	8 possible gain states can be written via the serial interface

Table 22 : [36],[24] - Gain Value

All 8 binary codes can be written to the core via the serial interface. Only the 4 thermometer codes 000,001,011 and 111 are selected by the automatic exposure algorithm. The 4 other codes are however still valid and will be evaluated as detailed in the table below. It is clear, from the non-linear relationship between the binary code and the actual gain applied at the analogue output stage, that care should be taken when using non thermometer code gain settings. If the user writes a gain code of 110 (real gain = 1.600) and then enables automatic gain control and the controller then decided to reduce the gain, the new gain value would be 011 (real gain = 4.000) i.e. the effective applied gain at the analogue output stage has actually been increased. Care must be taken when writing manual gain values.

The effective system gain for a given binary gain code is as follows:

VV5301/6301	
Gain binary code	Effective system gain
000	1.000
001	2.000
010	1.333
011	4.000
100	1.143

Table 23 : System Gain

VV5301/6301	
Gain binary code	Effective system gain
101	2.667
110	1.600
111	8.000

Table 23 : System Gain

The *undivided* input crystal clock is used by the clock generator circuitry, elements of the serial interface and a small number of other registers in the design. The remaining digital logic and the analogue circuitry, use internally generated clocks, namely the pixel clock and the faster ADC clocks. These clocks are all slower versions of the crystal clock. The ADC clocks may be up to half the crystal frequency, but can be further divided by factors of 2, 4 or 8. The pixel clock is lower frequency than the ADC clock.

Bit	Function	Default	Comment
1:0	Clock divisor value	0	Pixel clock = Crystal clock $\div 2^{n+1}$

Table 24 : [37],[25] - Clock Divisor Value

Bit	Function	Default	Comment
2:0	Gain limit	7	The programmed gain cannot be greater than this value

Table 25 : [38],[26] - Gain Limit

Bit	Function	Default	Comment
7:0	Exposure lower threshold	85	

Table 26 : [39],[27] - Exposure Lower Threshold

Bit	Function	Default	Comment
7:0	Exposure centre threshold	100	

Table 27 : [40],[28] - Exposure Centre Threshold

Bit	Function	Default	Comment
7:0	Exposure higher threshold	115	

Table 28 : [41],[29] - Exposure Higher Threshold

Preliminary Release

[41-47],[29-2F] - unused

[48-111],[30-6F] - reserved

7.5.4 System Registers [112-127],[70-7F]

[112],[70] - Black Calibration Setup Register

The sensor contains an automatic function to help maintain an ideal black level for the video signal. The centre 128 pixels, from the designated black lines are summed, averaged and then compared with a reference, to determine if the black level has to be adjusted. If an adjustment is required then the values of the 2 DAC registers, B0 and B1 - addresses [113-114],[71-72], can be altered to remove any offset in the video black level.

Bit	Function	Default	Comment
1:0	Black calibration trigger select	101	00 - Never BCal 01 - Always BCal 10 - BCal if failed monitor 11 - BCal if gain has changed
3:2	Black calibration monitor window select (pixel average comparison range)	00	00 - 14.00 to 17.99 01 - 13.00 to 18.99 10 - 12.00 to 19.99 11 - 11.00 to 20.99
4	Monitor window size set by serial interface. Yes/No	0	If enabled the monitor window size is set directly by the user via the serial interface
5	Narrow bcal target window Yes/No	0	If enabled the bcal test target window can be narrowed to force pixel black level closer to the ideal 16.00 value.
6	External black calibration DAC register values Yes/No	0	If enabled the DAC values used by the analogue sensor core
7	unused	0	

Table 29 : [112],[70] - Black Calibration Window Parameters

It is strongly recommended that the user select 2'b01 for bits[1:0] of register[112],[70]. This will ensure that the black calibration algorithm will run each field.

The monitor window size is programmable. If bit 4 of the register above is set then bits[3:2] will determine the size of the monitor window otherwise the current gain setting will fix the monitor window width.

There are two DAC value adjustment phases during black calibration. The first is a successive approximation technique to establish an *approximate* value for the DAC register. This estimate is then improved by a linear tracking routine. The latter will change the DAC register setting if the current pixel average is outwith the black calibration target window. The target window can also be altered via the serial interface.

It will only be possible to read back the values of the DAC registers, as set by the automatic black cal algorithm, with the VV5301/VV6301 sensors.

Bit	Function	Default	Comment
7:0	bcal0	80H	This register is read only

Table 30 : [113],[71] - Black Calibration DAC B0

Bit	Function	Default	Comment
7:0	bcal1	80H	This register is read only

Table 31 : [114],[72] - Black Calibration DAC B0

[116],[74] - System Test

The sensor can operate in several different test modes. These test modes detect faults in the sensor pixel array and the supporting analogue circuitry. Only one test mode should be enabled at any time.

Bit	Function	Default	Comment
0	reserved	0	
1	Tristate digital outputs Yes/No	0	If enabled the upper nibble of the data bus, FST & QCK will be tristated.
2	reserved	0	
3	Tristate digital outputs Yes/No	0	If enabled the lower nibble of the data bus will be tristated.
6:4	reserved		
7	unused		

Table 32 : [116],[74] - System Test

[118-119],[76-77] - Analogue Control Registers

There are 2 registers used to configure the custom analogue section of the sensor.

Bit	Function	Default	Comment
0	Enable bit line clamp Off/On	0	
1	Inhibit horizontal shift register Off/On	0	
2	Enable anti-blooming protection Off/On	0	
3	Inhibit OSA fast reset Off/On	0	
4	External bit line white reference Off/On	0	
5	Inhibit array read during blank lines Off/On	0	Disable additional MFI and BLOOP signals

Table 33 : [118],[76] - Analogue Control Register 0

Bit	Function	Default	Comment
6	unused	0	
7	RST/MRST clock select	0	0 - adck0 1 - adck1

Table 33 : [118],[76] - Analogue Control Register 0

Bit	Function	Default	Comment
0	Enable Mag_B0 Off/On	0	Double magnitude of B0 DAC current
1	New PXRDB scheme Off/On	0	
2	B1 Offset DAC High Gain Select low (x1)/High (x2)	0	B1_HG
3	Stand-by Off/On	0	Powers down ALL analogue circuitry and the majority of the digital logic
4	unused	0	
7:5	RST/MRST phase select	000	The RST/MRST timing signals can be delayed by up to 7 adck periods prior to transfer to the analogue circuits. 000 - no delay 001 - 1 adck period delay 010 - 2 adck period delay 011 - 3 adck period delay 100 - 4 adck period delay 101 - 5 adck period delay 110 - 6 adck period delay 111 - 7 adck period delay

Table 34 : [119],[77] - Analogue Control Register1

Preliminary Release

7.6 Types of messages

This section gives guidelines on the basic operations to read data from and write data to the serial interface.

The serial interface supports variable length messages. A message may contain no data bytes, one data byte or many data bytes. This data can be written to or read from common or different locations within the sensor. The range of instructions available are detailed below.

- Write no data byte, only sets the index for a subsequent read message.
- Single location data write or read for monitoring (real time control)
- Multiple location read or write for fast information transfers.

Examples of these operations are given below. A full description of the internal registers is given in the previous section. For all examples the slave address used is 32_{10} for writing and 33_{10} for reading. The write address includes the read/write bit (the lsb) set to zero while this bit is set in the read address.

7.6.1 Single location, single data write.

When a random value is written to the sensor, the message will look like this:

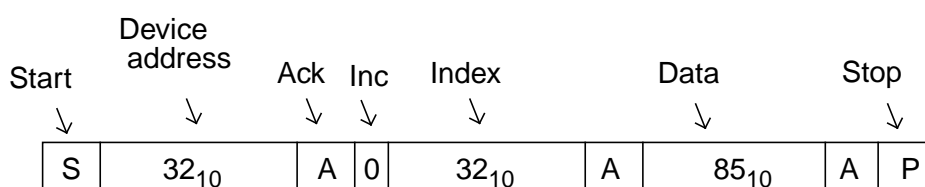

Figure 15 : Single location, single write.

In this example, the *fineH* exposure register (index = 32_{10}) is set to 85_{10} . The r/w bit is set to zero for writing and the *inc* bit (msbit of the index byte) is set to zero to disable automatic increment of the index after writing the value. The address index is preserved and may be used by a subsequent read. The write message is terminated with a stop condition from the master.

7.6.2 Single location, single data read.

A read message always contains the index used to get the first byte.



Figure 16 : Single location, single read.

This example assumes that a write message has already taken place and the residual index value is 32_{10} . A value of 85_{10} is read from the *fineH* exposure register. Note that the read message is terminated with a negative acknowledge (\bar{A}) from the master: it is not guaranteed that the master will be able to issue a stop condition at any other time during a read message. This is because if the data sent by the slave is all zeros, the *sda* line cannot rise, which is part of the stop condition.

7.6.3 No data write followed by same location read.

When a location is to be read, but the value of the stored index is not known, a write message with no data byte must be written first, specifying the index. The read message then completes the message sequence. To avoid relinquishing the serial to bus to another master a repeated start condition is asserted between the write and read messages, i.e. no stop condition is asserted. In

this example, the *gain* value (index = 36₁₀) is read as 15₁₀:

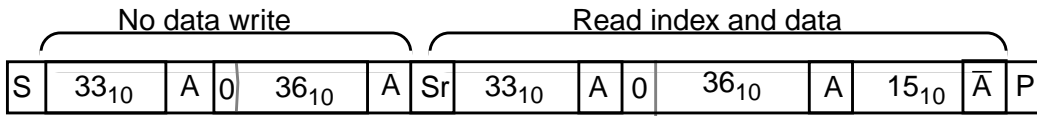

Figure 17 : No data write followed by same location read.

As mentioned in the previous example, the read message is terminated with a negative acknowledge (\bar{A}) from the master.

7.6.4 Same location multiple data write.

It may be desirable to write a succession of data to a common location. This is useful when the status of a bit must be toggled.

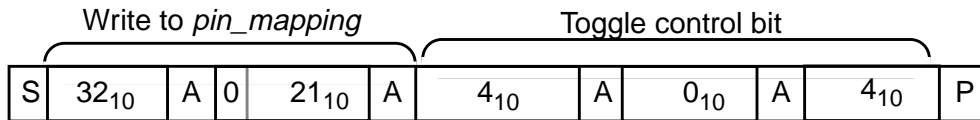

Figure 18 : Same location multiple data write.

7.6.5 Same location multiple data read

When an exposure related value (*fineH*, *fineL*, *coarseH*, *coarseL*, *gain* or *clk_div*) is written, it takes effect on the output at the beginning of the next video frame, (remember that the application of the *gain* value is a frame later than the other exposure parameters). To signal the consumption of the written value, a flag is set when any of the exposure or gain registers are written and is reset at the start of the next frame. This flag appears in *status0* register and may be monitored by the bus master. To speed up reading from this location, the sensor will repeatedly transmit the current value of the register, as long as the master acknowledges each byte read.

In the below example, a *fineH* exposure value of 0 is written, the status register is addressed (no data byte) and then constantly read until the master terminates the read message.

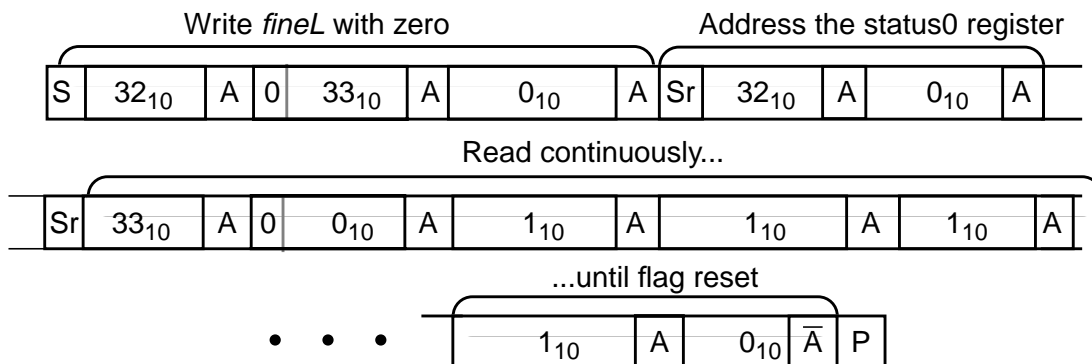

Figure 19 : Same location multiple data read.

7.6.6 Multiple location write

If the automatic increment bit is set (msb of the index byte), then it is possible to write data bytes to consecutive adjacent internal registers, (i.e. 23,24,25,26 etc), without having to send explicit indexes prior to sending each data byte. An auto-increment write to the exposure registers with their default values is shown in the following example, where we write 17₁₀ to the pin_mapping register[21] and 193₁₀ to the data format register[22].

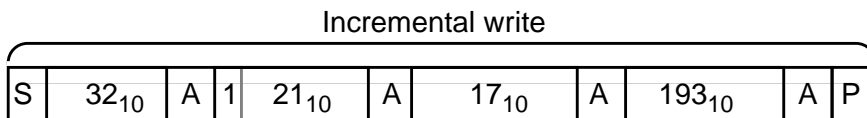

Figure 20 : Multiple location write.

7.6.7 Multiple location read

In the same manner, multiple locations can be read with a single read message. In this example the index is written first, to ensure the exposure related registers are addressed and then they are read. Note that the user will get the base index, in this case 32₁₀, read back *twice* before the first data byte is read back. The user must therefore always request an extra byte of data to be read back.

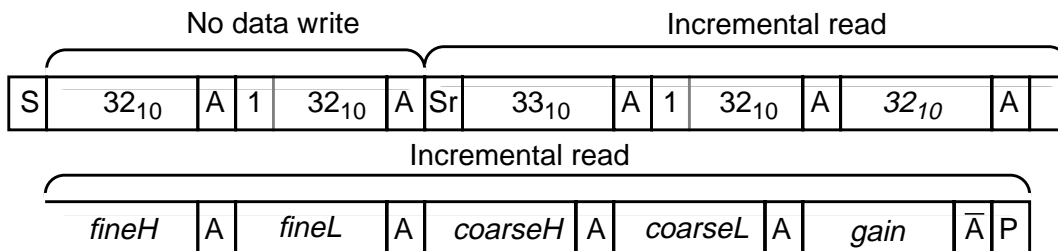

Figure 21 : Multiple location read.

Note that a stop condition is not required after the final negative acknowledge from the master, the sensor will terminate the communication upon receipt of the negative acknowledge from the master.

7.7 Serial Interface Timing

Parameter	Symbol	Min.	Max.	Unit
SCL clock frequency	fscl	0	100	kHz
Bus free time between a stop and a start	tbuf	2	-	us
Hold time for a repeated start	thd;sta	80	-	ns
LOW period of SCL	tlow	320	-	ns
HIGH period of SCL	thigh	160	-	ns
Set-up time for a repeated start	tsu;sta	80	-	ns
Data hold time	thd;dat	0	-	ns
Data Set-up time	tsu;dat	0	-	ns

Table 35 : Serial Interface Timing Characteristics

Preliminary Release

Parameter	Symbol	Min.	Max.	Unit
Rise time of SCL, SDA	tr	-	300	ns
Fall time of SCL, SDA	tf	-	300	ns
Set-up time for a stop	tsu;sto	80	-	ns
Capacitive load of each bus line (SCL, SDA)	Cb	-	200	pF

Table 35 : Serial Interface Timing Characteristics

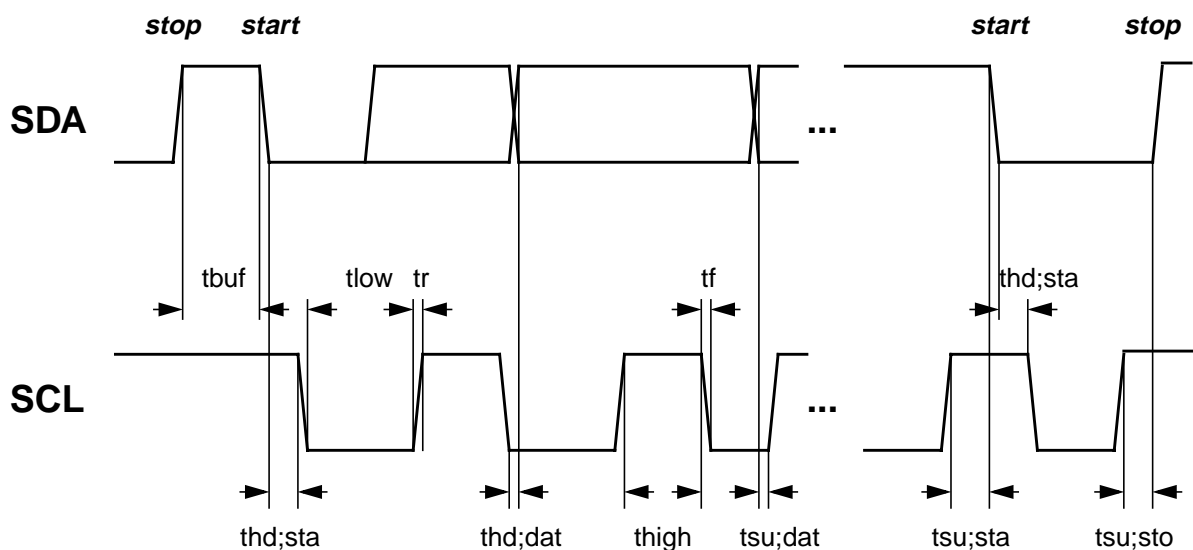

all values referred to the minimum input level (high) = 3.5V, and maximum input level (low) = 1.5V

Figure 22 : Serial Interface Timing Characteristics

Preliminary Release

8. Detailed AC/DC Specification

8.1 VV5301/VV6301 AC/DC Specification

Image Format	160 x 120 pixels (QSIF)
Image size output	164 x 124 pixels
Pixel Size	12.5 x 12.5 μ m
Array Format	SIF
Exposure control	up to 44000:1
Sensor signal / Noise ratio	36dB
Supply Voltage	5.0v +/-10%
Package type	48BGA
Operating Temp. range	0°C - 40°C
Logic 0 input	0.2 x Vdd Max
Logic 1 input	0.8 x Vdd Min
Serial interface frequency range	0-100kHz

Table 36 : VV5301/VV6301 AC/DC specification

8.2 VV5301/VV6301 Power Consumption

Low power mode current consumption	4.6mA
Normal operating mode current consumption	15.1mA

Table 37 : VV5301/VV6301 Current consumption in different modes

8.3 Digital Input Pad Pull-up and Pull-down Resistors

Pad Type	Pads	Typical resistance
Library pulldown	d[7:0],hpix,sin	tba
Library pullup	scl, sda, ce, qcktri	tba

Table 38 : VV5301/ 6301 pull up/pull down resistor specification

9. Pinout and Pin Descriptions

BGA Pin	Name	Type	Description
POWER SUPPLIES			
C5	AVSS	GND	Analogue ground
A7	AVDD	PWR	Analogue power
D7	DVDD	PWR	Digital power
D5	VDD	PWR	Power
G7	VDD	PWR	Power
F6	VSS	GND	Ground
G2	VSS	GND	Ground
F3	VDD	PWR	Power
E1	VSS	GND	Ground
E2	DVSS	GND	Ground
ANALOGUE OUTPUTS			
B4	VRT	IA	Pixel reset voltage
A5	VCDS	IA	Voltage reference
B5	TEST	IA	Analogue test
C3	VREG	OA	Reference voltage input
B3	VBLOOM	OA	Internal reference voltage
A3	VBLTW	IA	Bitline test white reference
C4	VBG	OA	Internally generated bangap reference voltage 1.22V
A4	VREF2V5	OA	Internally generated reference voltage 2.5V
DIGITAL OUTPUTS			
E6	FST	OD	Frame start. Synchronises external image capture.
F7	QCK	OD	Pixel sample clock. Qualifies video output for external image capture.
G6,E5, G5,F5, G4,F4, G3,E4	D[7:0]	OD \uparrow	Parallel 8-wire databus. VV5301/VV6301 only, bidirectional pads always configured as outputs
DIGITAL CONTROL SIGNALS			
E3	SCL	BI \uparrow	Serial bus clock (bidirectional, open drain)
F1	SDA	BI \uparrow	Serial bus data (bidirectional, open drain)
D1	QCKTRI	ID \downarrow	QCK tristate
D2	CE	ID \uparrow	Chip enable

BGA Pin	Name	Type	Description
A6	HPIX	ID↓	Hold pixel value.
E7	SIN	ID↓	Sensor synchronisation
SYSTEM CLOCKS			
G1	CLKI	ID	Oscillator input.
F2	CLKO	OD	Oscillator output.

Key			
A	Analog Input	ID	Digital Input
OA	Analog Output	ID↑	Digital input with internal pull-up
BI	Bidirectional	ID↓	Digital input with internal pull-down
BI↑	Bidirectional with internal pull-up	OD	Digital Output
BI↓	Bidirectional with internal pull-down	ODT	Tri-stateable Digital Output

10. VV5301/VV6301 Recommended Reference Design

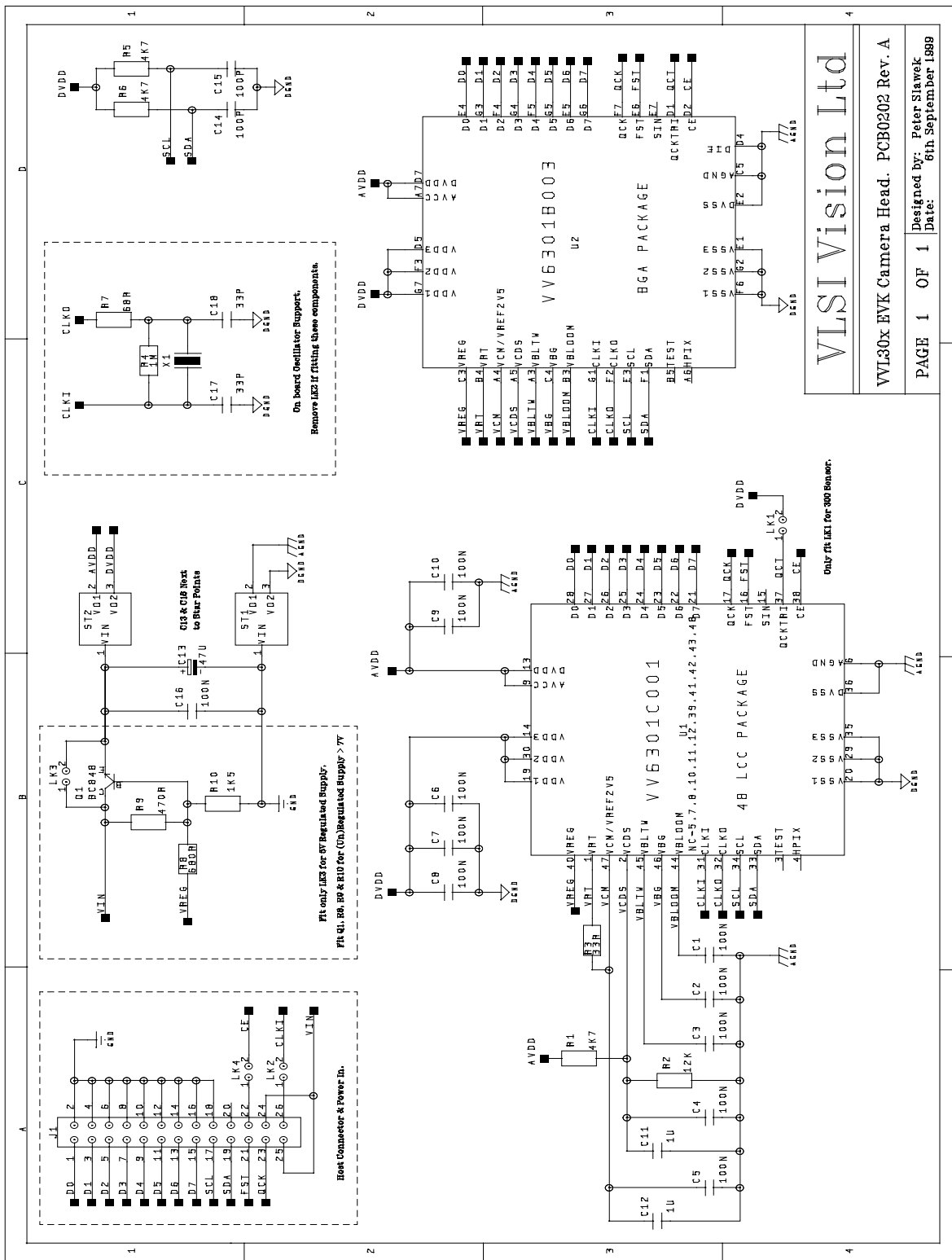

Preliminary Release

11. Package Details (48 pin BGA (VV5301/VV6301))

Preliminary Release

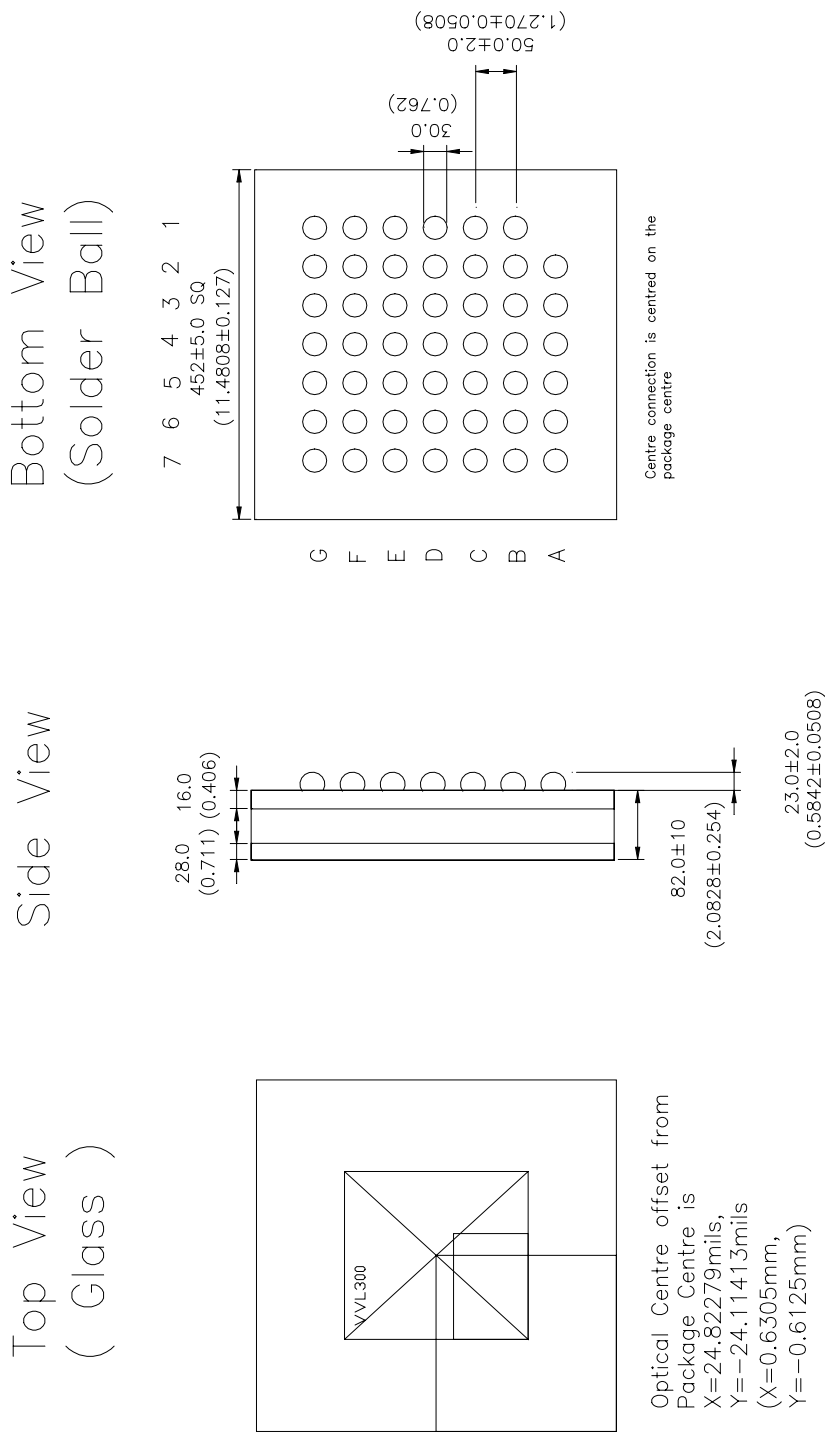

Figure 23 : Package drawing for 48pin BGA with VVx301

12. Evaluation kits (EVK's)

It is highly recommended that an Evaluation Kit (EVK) is used for initial evaluation and design-in of the VV5301/VV6301. Please contact STMicroelectronics for further details.

13. Ordering Details

Part Number	Description
VV5301B001	BGA packaged, QSIF Monochrome sensor
VV6301B001	BGA packaged, QSIF Colour sensor
STV-5301-R01	Reference design board for (mono) 5301 sensor
STV-6301-R01	Reference design board for (colour) 6301 sensor
STV-5301-E01	Evaluation kit (monochrome)
STV-6301-E01	Evaluation kit (colour)

Information furnished is believed to be accurate and reliable. However, STMicroelectronics assumes no responsibility for the consequences of use of such information nor for any infringement of patents or other rights of third parties which may result from its use. No license is granted by implication or otherwise under any patent or patent rights of STMicroelectronics. Specifications mentioned in this publication are subject to change without notice. This publication supersedes and replaces all information previously supplied. STMicroelectronics products are not authorized for use as critical components in life support devices or systems without express written approval of STMicroelectronics

The ST logo is a registered trademark of STMicroelectronics

© 1999 STMicroelectronics - All Rights Reserved



www.vvl.co.uk

www.st.com

asiapacific_sales@vvl.co.uk
central_europe_sales@vvl.co.uk
france_sales@vvl.co.uk
japan_sales@vvl.co.uk
nordic_sales@vvl.co.uk
southern_europe_sales@vvl.co.uk
uk_eire_sales@vvl.co.uk
usa_sales@vvl.co.uk

VLSI VISION LIMITED

A company of the ST Microelectronics Group



cd5301_6301_f.fm

49/49