



## DESCRIPTION

The A7404 is a wide input range, high-efficiency, and high frequency DC-to-DC step-down switching regulator, capable of delivering up to 0.4A of output current. With a fixed switching frequency of 750kHz, this current mode PWM controlled converter allows the use of small external components, such as ceramic input and output caps, as well as small inductors. A7404 also employs a proprietary control scheme that switches the device into a power save mode during light load, thereby extending the range of high efficiency operation. An OVP function protects the IC itself and its downstream system against input voltage surges. With this OVP function, the IC can stand off input voltage as high as 42V, making it an ideal solution for industrial applications such as smart meters as well as automotive applications.

In automotive systems, power comes from the battery, with its voltage typically between 9V and 24V. Including cold crank and double battery jump-starts, the minimum input voltage may be as low as 4V and the maximum up to 36V, with even higher transient voltages. With these high input voltages, linear regulators cannot be used for high supply currents without overheating the regulator. Instead, high efficiency switching regulators such as A7404 must be used to minimize thermal dissipation.

The A7404 is available in SOT-26 package.

## ORDERING INFORMATION

Package Type	Part Number	
SOT-26	E6	A7404E6R
		A7404E6VR
Note	V: Halogen free Package R: Tape & Reel	
AiT provides all RoHS products		
Suffix " V " means Halogen free Package		

## FEATURES

- Wide Input Operating Range from 4V to 38V
- Standoff Input Voltage: 42V
- High Efficiency at 20V In 12V Out Up to 95%
- High Efficiency PFM mode at light load
- Capable of Delivering 0.4A of output current.
- No External Compensation Needed
- Current Mode control
- Logic Control Shutdown
- Thermal shutdown and UVLO
- Available in SOT-26 Package

## APPLICATION

- Smart Meters
- Industrial Applications
- Automotive Applications

## TYPICAL APPLICATION

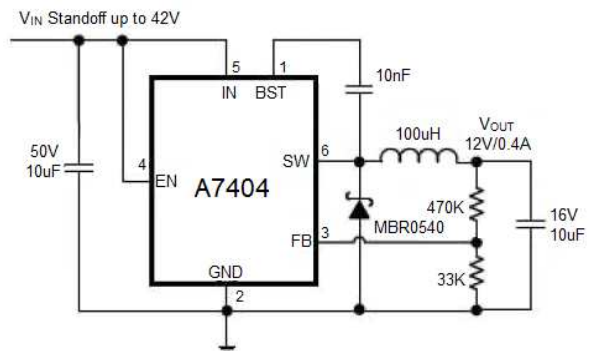



## PIN DESCRIPTION

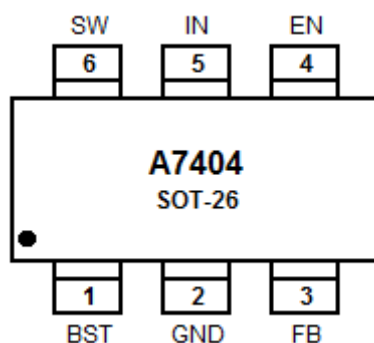

Top View

Pin #	Symbol	Function
1	BST	Bootstrap pin. Connect a 10nF capacitor from this pin to SW
2	GND	Ground
3	FB	Feedback Input. Connect an external resistor divider from the output to FB and GND to set $V_{OUT}$
4	EN	Enable pin for the IC. Drive this pin high to enable the part, low to disable.
5	IN	Supply Voltage. Bypass with a 10 $\mu$ F ceramic capacitor to GND
6	SW	Inductor Connection. Connect an inductor Between SW and the regulator output.



## ABSOLUTE MAXIMUM RATINGS

Input Voltage Range	-0.3V~42V	
T <sub>J</sub> , Max Operating Junction Temperature	150°C	
SW, EN Voltage	-0.3V~V <sub>IN</sub> +0.3V	
BST Voltage	-0.3V~SW+6V	
FB Voltage	-0.3V~6V	
SW to ground current	Internally limited	
T <sub>O</sub> , Operating Temperature	-40°C~85°C	
θ <sub>JC</sub> , Package Thermal Resistance	SOT-26	110°C/W
T <sub>S</sub> , Storage Temperature	-55°C~150°C	

Stress beyond above listed "Absolute Maximum Ratings" may lead permanent damage to the device. These are stress ratings only and operations of the device at these or any other conditions beyond those indicated in the operational sections of the specifications are not implied. Exposure to absolute maximum rating conditions for extended periods may affect device reliability.

## ELECTRICAL CHARACTERISTICS

V<sub>IN</sub>=12V, unless otherwise specified. Typical values are at T<sub>A</sub>=25°C.

Parameter	Conditions	Min.	Typ.	Max.	Unit
Input Standoff Voltage		42			V
Input Voltage Range		4		38	V
Input UVLO	Rising, Hysteresis=140mV		3.80		V
Input OVP	Rising, Hysteresis=1.3V		38		V
Input Supply Current	V <sub>FB</sub> =0.85V		0.6		mA
Input Shutdown Current			6		μA
FB Feedback Voltage		0.780	0.800	0.820	V
FB Input Current			0.01		μA
Switching Frequency			750		kHz
Maximum Duty Cycle		90			%
FoldBack Frequency	V <sub>FB</sub> =0V		95		kHz
High side Switch On Resistance	I <sub>SW</sub> =200mA		550		mΩ
High side Switch Current Limit			0.7		A
SW Leakage Current	V <sub>IN</sub> =12V, V <sub>SW</sub> =0, EN=GND			10	μA
EN Input Current	V <sub>IN</sub> =12V, V <sub>EN</sub> =5V		1	5	μA
EN Input Low Voltage	Rising, Hysteresis=100mV	0.8	1.1	1.4	V
Thermal Shutdown	Hysteresis=40°C		150		°C



## TYPICAL PERFORMANCE CHARACTERISTICS

Typical values are at  $T_A=25^\circ\text{C}$ , unless otherwise specified.

1. Efficiency vs.  $I_{OUT}$

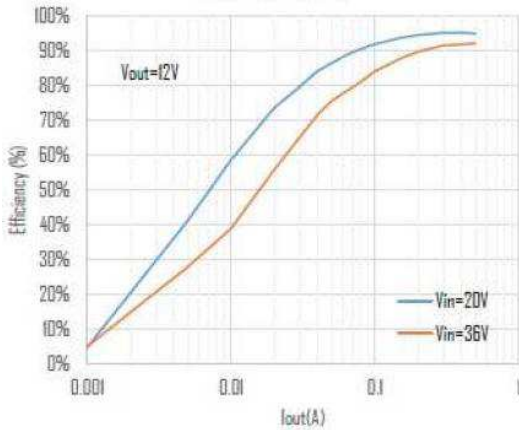

2. Output Voltage vs.  $I_{OUT}$

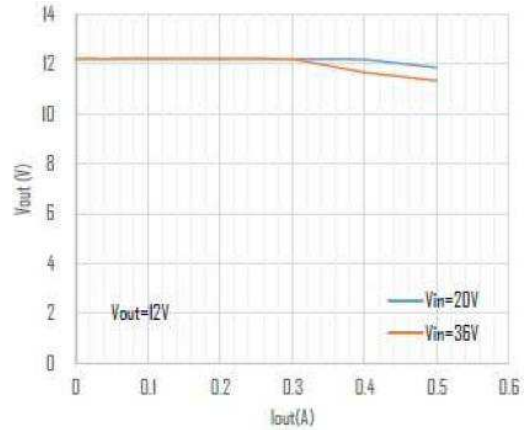

3. Frequency vs. Temperature

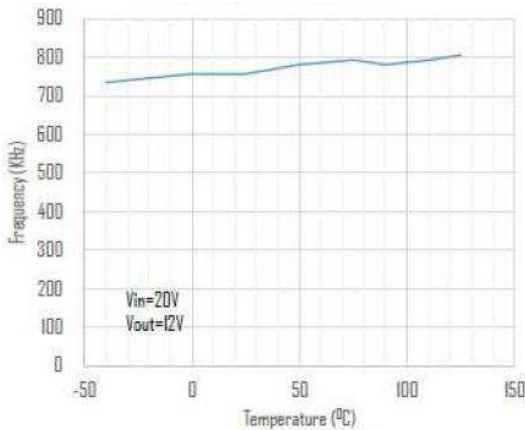

4. Maximum  $I_{OUT}$  vs. Temperature

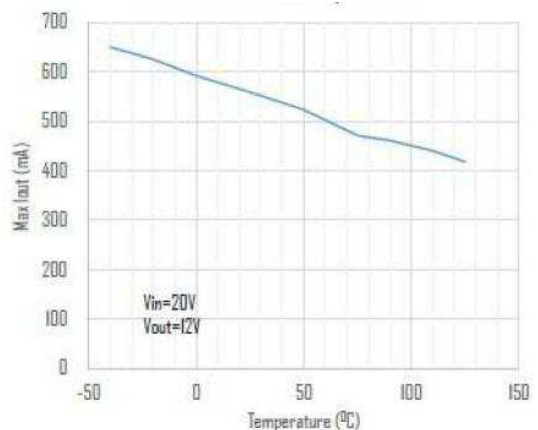

5. Efficiency vs.  $I_{OUT}$

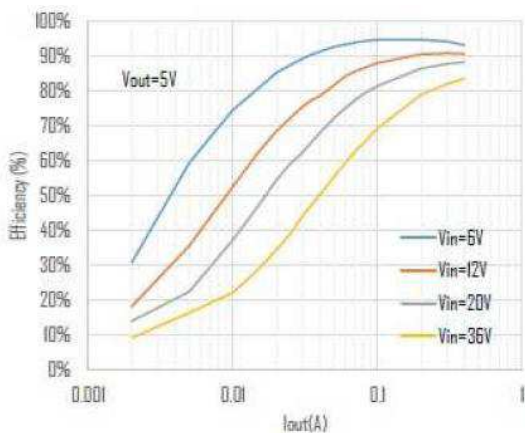

6. Output Voltage vs.  $I_{OUT}$

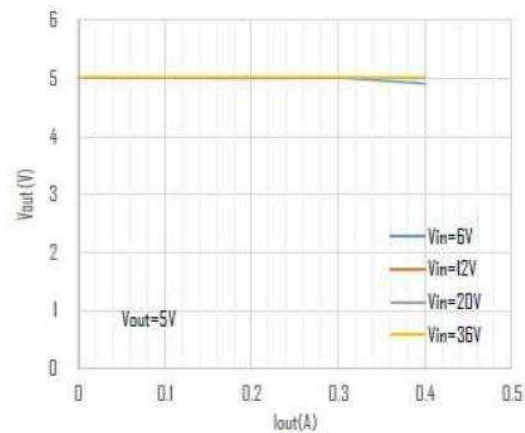



7. Efficiency vs.  $I_{out}$

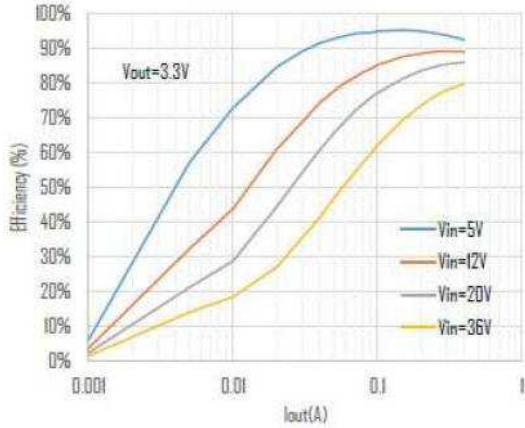

8. Output Voltage vs.  $I_{out}$

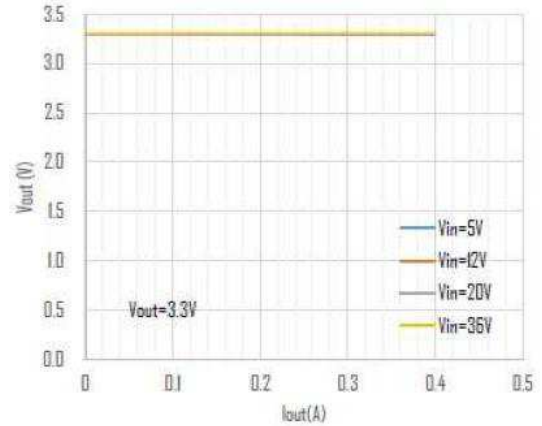

9. Switching Forms:  $V_{in}=12V, V_{out}=5V, I_{out}=10mA$

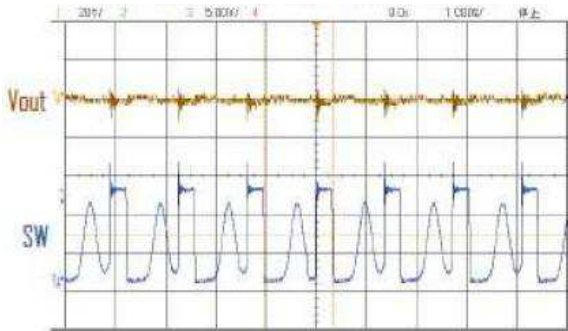

10. Switching Forms :  $V_{in}=12V, V_{out}=5V, I_{out}=25mA$

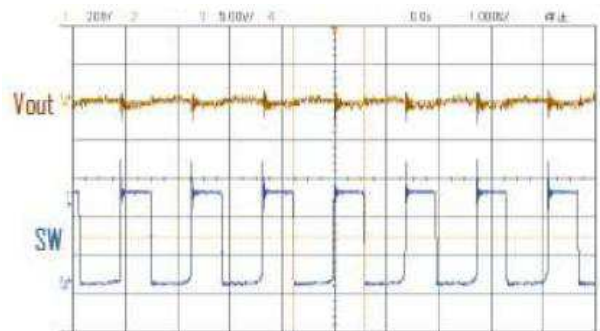

11. Switching Forms:  $V_{in}=20V, V_{out}=12V, I_{out}=5mA$

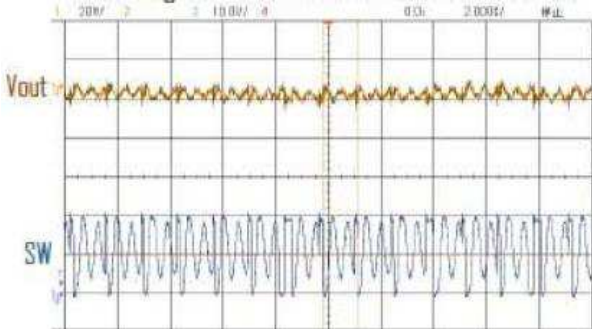

12. Switching Forms:  $V_{in}=20V, V_{out}=12V, I_{out}=30mA$

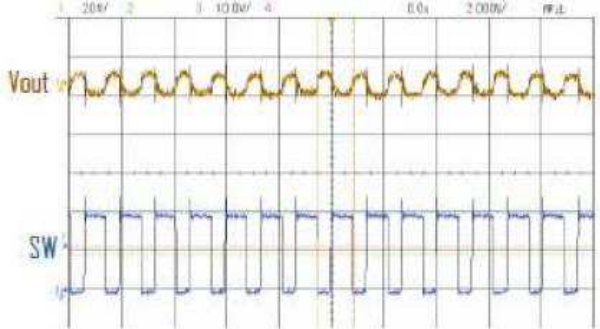

13. Output Short Response  $V_{in}=36V, V_{out}=12V$

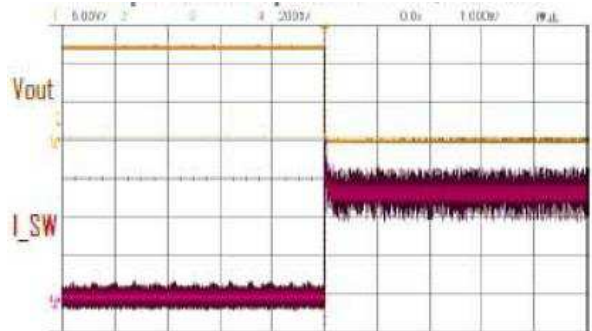

14. Output Short Recover  $V_{in}=36V, V_{out}=12V$

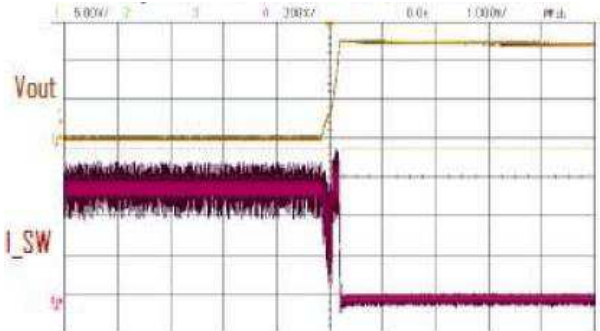





## DETAILED INFORMATION

### Functional Descriptions

#### Loop Operation

The A7404 is a wide input range, high-efficiency, DC-to-DC step-down switching regulator, capable of delivering up to 0.4A of output current, integrated with a 550mΩ high side MOSFET. It uses a PWM current-mode control scheme. An error amplifier integrates error between the FB signal and the internal reference voltage. The output of the integrator is then compared to the sum of a current-sense signal and the slope compensation ramp. This operation generates a PWM signal that modulates the duty cycle of the power MOSFETs to achieve regulation for output voltage.

#### Light Load Operation

Traditionally, a fixed constant frequency PWM DC-DC regulator always switches even when the output load is small. When energy is shuffling back and forth through the power MOSFETs, power is lost due to the finite RDSONs of the MOSFETs and parasitic capacitances. At light load, this loss is prominent and efficiency is therefore very low. A7404 employs a proprietary control scheme that improves efficiency in this situation by enabling the device into a power save mode during light load, thereby extending the range of high efficiency operation.



## PACKAGE INFORMATION

Dimension in SOT-26 Package (Unit: mm)

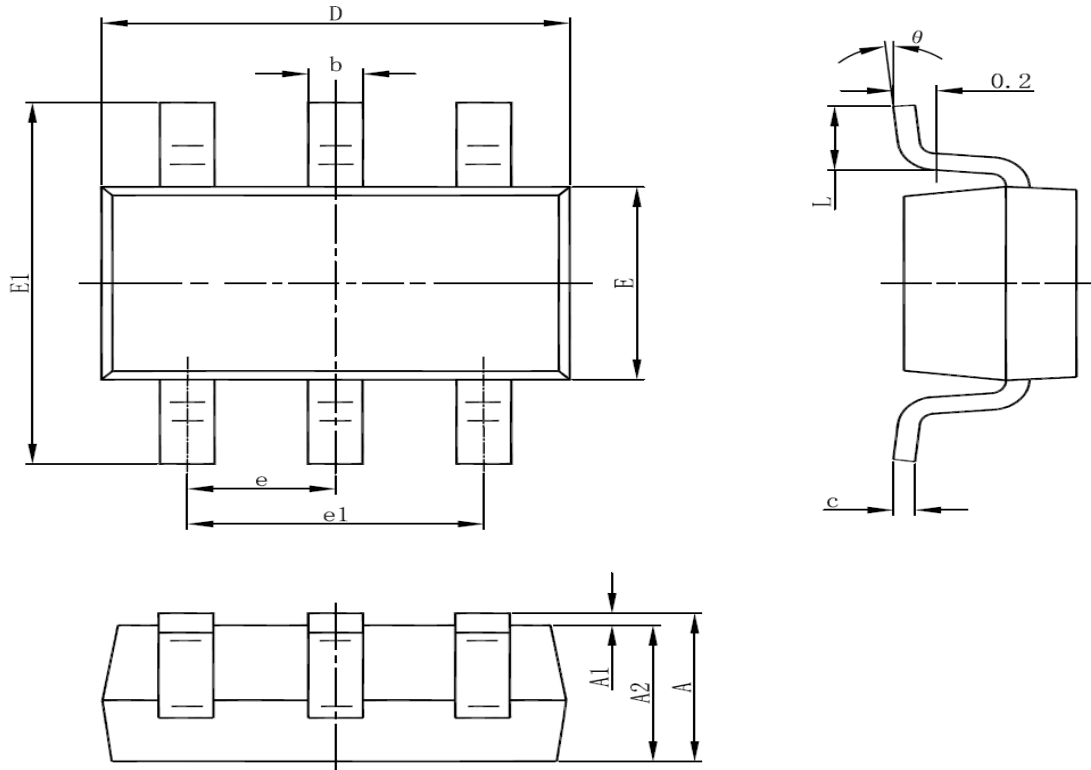

SYMBOL	MIN	MAX
A	1.050	1.250
A1	0.000	0.100
A2	1.050	1.150
b	0.300	0.500
c	0.100	0.200
D	2.820	3.020
E	1.500	1.700
E1	2.650	2.950
e	0.950(BSC)	
e1	1.800	2.000
L	0.300	0.600
$\theta$	0°	8°





## IMPORTANT NOTICE

AiT Semiconductor Inc. (AiT) reserves the right to make changes to any its product, specifications, to discontinue any integrated circuit product or service without notice, and advises its customers to obtain the latest version of relevant information to verify, before placing orders, that the information being relied on is current.

AiT Semiconductor Inc.'s integrated circuit products are not designed, intended, authorized, or warranted to be suitable for use in life support applications, devices or systems or other critical applications. Use of AiT products in such applications is understood to be fully at the risk of the customer. As used herein may involve potential risks of death, personal injury, or severe property, or environmental damage. In order to minimize risks associated with the customer's applications, the customer should provide adequate design and operating safeguards.

AiT Semiconductor Inc. assumes to no liability to customer product design or application support. AiT warrants the performance of its products of the specifications applicable at the time of sale.