



Low Power Schottky Logic – 74LS86A

Quadruple 2-Input Exclusive OR Gate IC in bare die form

Rev 1.0
21/11/17

Description

The 74LS86A is fabricated using a 2µm 40V Bipolar process. The device contains four independent gates and performs the Boolean functions $Y = A \oplus B = \overline{A}B + A\overline{B}$ in positive logic.

Features:

- High speed – 22ns (Typ) propagation delay
- Low Power – I_{CC} 10mA Max
- Direct drop-in replacement for obsolete components in long term programs.

Ordering Information

The following part suffixes apply:

- No suffix - MIL-STD-883 /2010B Visual Inspection

For High Reliability versions of this product please see

[54LS86A](#)

Die Dimensions in µm (mils)

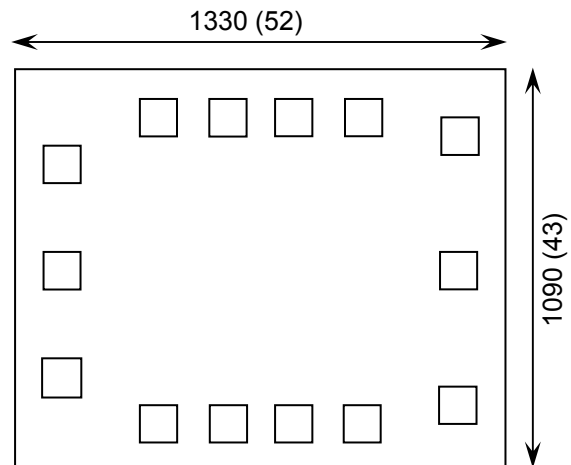

Supply Formats:

- Default – Die in Waffle Pack (400 per tray capacity)
- Sawn Wafer on Tape – On request
- Unsawn Wafer – On request
- Die Thickness <=> 350µm(14 Mils) – On request
- Assembled into Plastic Package – On request

Mechanical Specification

Die Size (Unsawn)	1330 x 1090 52 x 43	µm mils
Minimum Bond Pad Size	98 x 98 3.86 x 3.86	µm mils
Die Thickness	350 (±20) 13.78 (±0.79)	µm mils
Top Metal Composition	Al 1%Si 1.1µm	
Back Metal Composition	N/A – Bare Si	





Low Power Schottky Logic – 74LS86A

Rev 1.0
21/11/17

Pad Layout and Functions

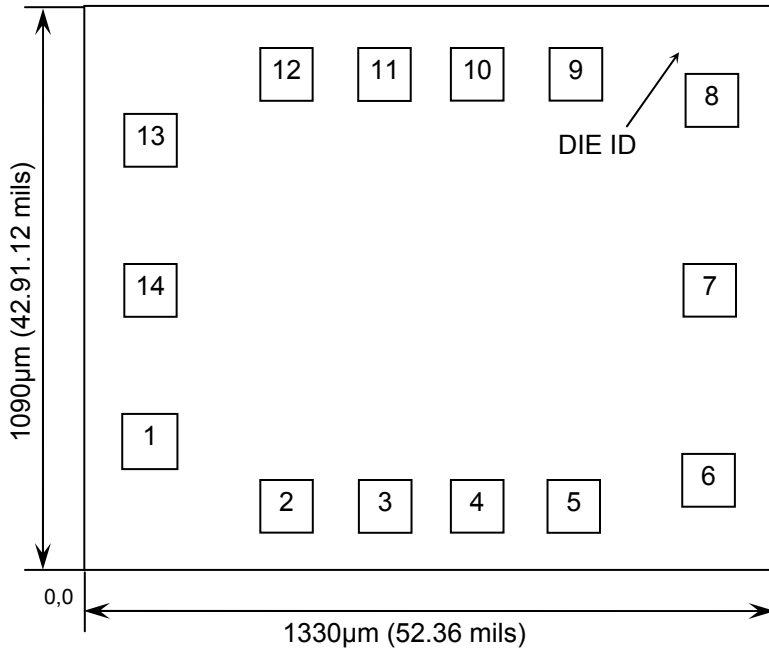

PAD	FUNCTION	COORDINATES (mm)	
		X	Y
1	A1	0.077	0.205
2	B1	0.338	0.079
3	Y1	0.528	0.079
4	A2	0.704	0.079
5	B2	0.894	0.079
6	Y2	1.154	0.129
7	GND	1.154	0.496
8	Y3	1.154	0.863
9	A3	0.894	0.913
10	B3	0.704	0.913
11	Y4	0.528	0.913
12	A4	0.338	0.913
13	B4	0.077	0.787
14	V _{CC}	0.077	0.496

CONNECT CHIP BACK TO GND OR FLOAT

Logic Diagram

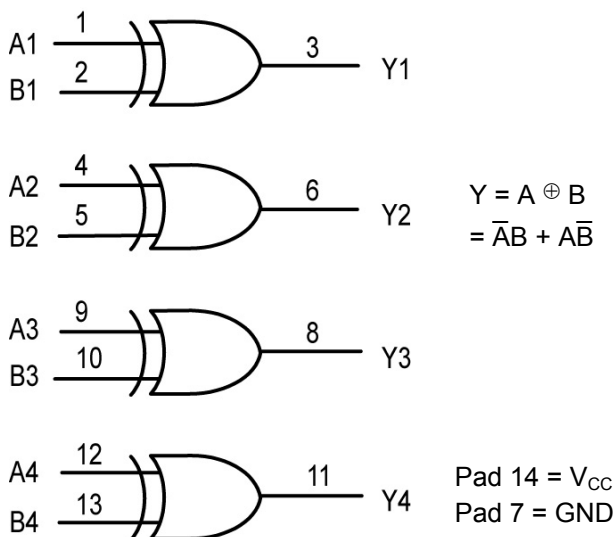

Truth Table

INPUTS		OUTPUT
A	B	Y
L	L	L
L	H	H
H	L	H
H	H	L

H = High level (steady state)
 L = Low level (steady state)





Low Power Schottky Logic – 74LS86A

Rev 1.0
21/11/17

Absolute Maximum Ratings¹

PARAMETER	SYMBOL	VALUE	UNIT
DC Supply Voltage	V_{CC}	7.0	V
DC Input Voltage	V_{IN}	7.0	V
DC Input Voltage	V_{OUT}	5.5	°C
Storage Temperature Range	T_{STG}	-65 to 150	°C

1. Operation above the absolute maximum rating may cause device failure. Operation at the absolute maximum ratings, for extended periods, may reduce device reliability.

Recommended Operating Conditions

PARAMETER	SYMBOL	MIN	MAX	UNITS
Supply Voltage	V_{CC}	4.75	5.25	V
High-Level Input Voltage	V_{IH}	2	-	V
Low-Level Input Voltage	V_{IL}	-	0.8	V
High-Level Output Current	I_{OH}	-	-0.4	mA
Low-Level Output Current	I_{OL}	-	8	mA
Operating Temperature Range	T_J	0	+85	°C

DC Electrical Characteristics² $T_J = 0^\circ\text{C}$ to 85°C unless otherwise specified

PARAMETER	SYMBOL	CONDITIONS	LIMITS			UNITS
			MIN	TYP	MAX	
Minimum High-Level Input Voltage	V_{IH}	-	2	-	-	V
Maximum Low-Level Input Voltage	V_{IL}	-	-	-	0.8	V
Input Clamp Diode Voltage	V_{IK}	$V_{CC} = \text{MIN}$ $I_{IN} = -18\text{mA}$	-	-0.65	-1.5	V
Output Voltage High	V_{OH}	$V_{CC} = \text{MIN}, I_{OH} = \text{MAX}$ $V_{IN} = V_{IL}$ or V_{IH} per Function Table	2.7	3.5	-	V
Output Voltage Low	V_{OL}	$V_{CC} = \text{MIN}$ $I_{OH} = \text{MAX}$ $V_{IN} = V_{IL}$ or V_{IH} per Truth Table $I_{OL} = 8\text{mA}$	-	0.36	0.5	V
Input High Current	I_{IH}	$V_{CC} = \text{MAX}, V_{IN} = 2.7\text{V}$	-	-	40	μA
		$V_{CC} = \text{MAX}, V_{IN} = 7.0\text{V}$	-	-	0.2	mA
Input Low Current	I_{IL}	$V_{CC} = \text{MAX}, V_{IN} = 0.4\text{V}$	-	-	-0.8	mA
Short Circuit Current ³	I_{OS}	$V_{CC} = \text{MAX}$	-20	-	-100	mA
Power Supply Current (Total)	I_{CC}	$V_{CC} = \text{MAX}$	-	6.1	10	mA

2. All typical values @ $V_{CC} = 5\text{V}$, $T_J = 25^\circ\text{C}$. 3. Not more than one output should be shorted at a time, nor for more than 1 second.





Low Power Schottky Logic – 74LS86A

Rev 1.0

21/11/17

AC Electrical Characteristics⁴

PARAMETER	SYMBOL	CONDITIONS	LIMITS			UNITS
			MIN	TYP	MAX	
Propagation Delay, Other Input Low	t_{PLH}	$V_{CC} = 5V, C_L = 15pF$	-	12	23	ns
	t_{PHL}			10	17	
Propagation Delay, Other Input High	t_{PLH}	$V_{CC} = 5V, C_L = 15pF$	-	20	30	ns
	t_{PHL}		-	13	22	

4. Not production tested in die form, characterized by chip design and tested in package.

DISCLAIMER: The information given in this document shall in no event be regarded as a guarantee of conditions or characteristics. With respect to any examples or hints given herein, any typical values stated herein and/or any information regarding the application of the device, Silicon Supplies Ltd hereby disclaims any and all warranties and liabilities of any kind.

LIFE SUPPORT POLICY: Silicon Supplies Ltd components may be used in life support devices or systems only with the express written approval of Silicon Supplies Ltd, if a failure of such components can reasonably be expected to cause the failure of that life support device or system or to affect the safety or effectiveness of that device or system. Life support devices or systems are intended to be implanted in the human body or to support and/or maintain and sustain and/or protect human life. If they fail, it is reasonable to assume that the health of the user or other persons may be endangered.

