

1-PORT 100BASE-T SMD RJ45 WITH INTEGRATED MAGNETICS

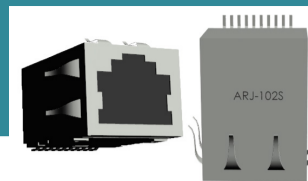

ARJ-102S

23.05 x 16.80 x 13.65mm
RoHS/RoHS II Compliant

FEATURES

- 10/100/1000Base-T compatibility
- Surface mount device
- Wide -40C to 85C operating temperature range
- Integrated magnetics
- Integrated shielding and metal fingers for excellent EMI performance

APPLICATIONS

- Industrial IoT/IoT
- Video IP cameras
- Machine-to-machine (M2M)
- Industrial process control
- Industrial robotics

STANDARD SPECIFICATIONS

PARAMETERS	MINIMUM	TYPICAL	MAXIMUM	UNITS	NOTES
Turn Ratio ($\pm 3\%$)	1CT:1CT				
Inductance	350			μH	100kHz, 0.1Vrms, 8mADC
Insertion Loss			-1.0	dB	1-100MHz
Return Loss	-18			dB	1-30MHz
	-15				30-60MHz
	-12				60-80MHz
	-10				80-100MHz
Crosstalk	-37			dB	1-30MHz
	-32				30-60MHz
	-27				60-100MHz
CMR	-35			dB	1-30MHz
	-30				30-100MHz
Hipot	1500 Vrms min				Pri to Sec

REVISED: 08/08/2016

1-PORT 100BASE-T SMD RJ45 WITH INTEGRATED MAGNETICS

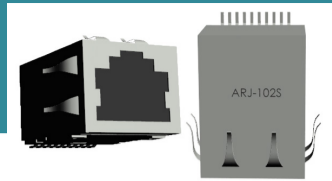

23.05 x 16.80 x 13.65mm
RoHS/RoHS II Compliant

ARJ-102S

PART IDENTIFICATION AND ORDERING INFORMATION

ARJ-102S-



PACKAGING
Blank: Bulk
T:100pcs/reel

MECHANICAL DIMENSIONS: mm (unless otherwise specific, tolerances are ± 0.25)

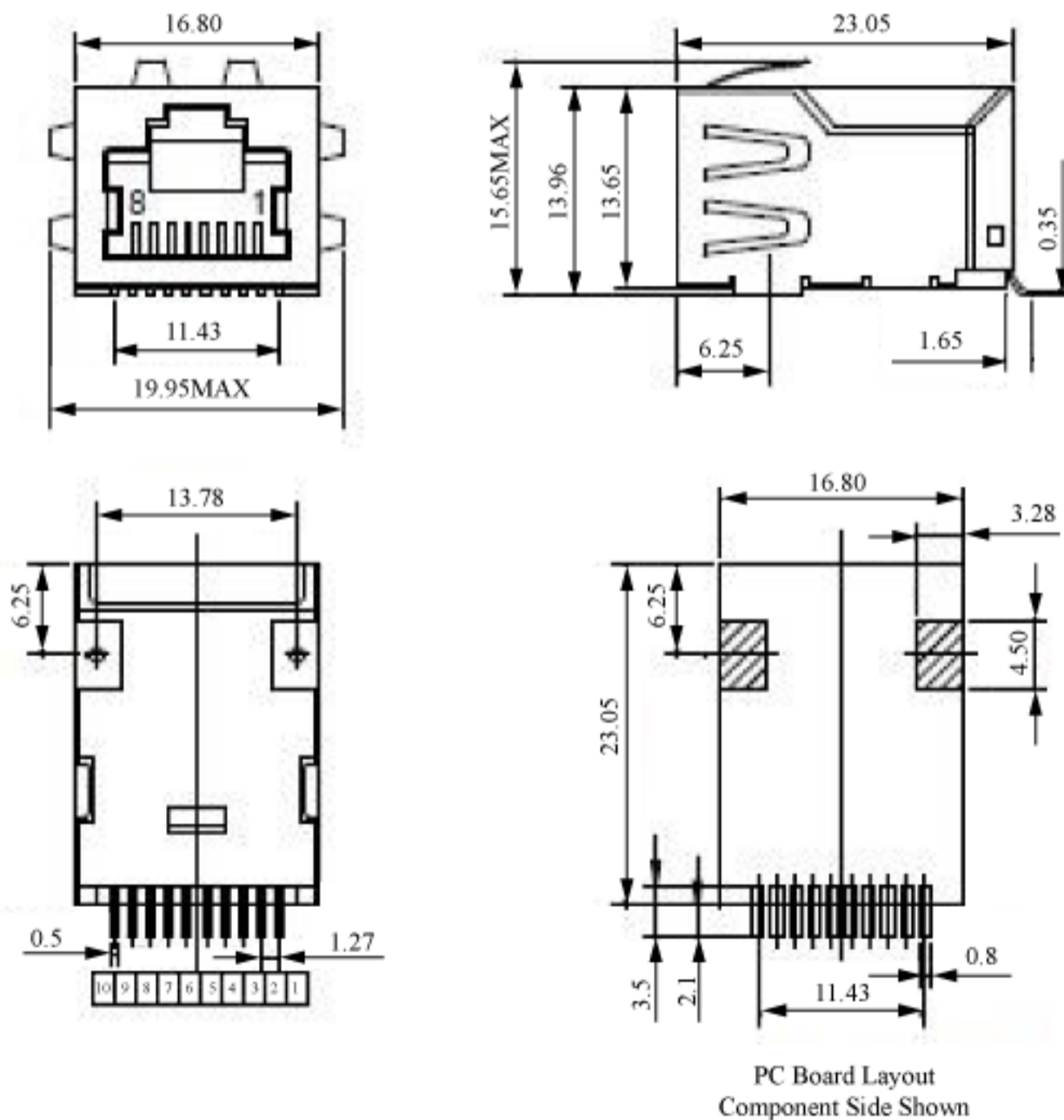

1-PORT 100BASE-T SMD RJ45 WITH INTEGRATED MAGNETICS

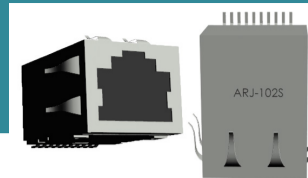

23.05 x 16.80 x 13.65mm
RoHS/RoHS II Compliant

ARJ-102S

SCHEMATIC

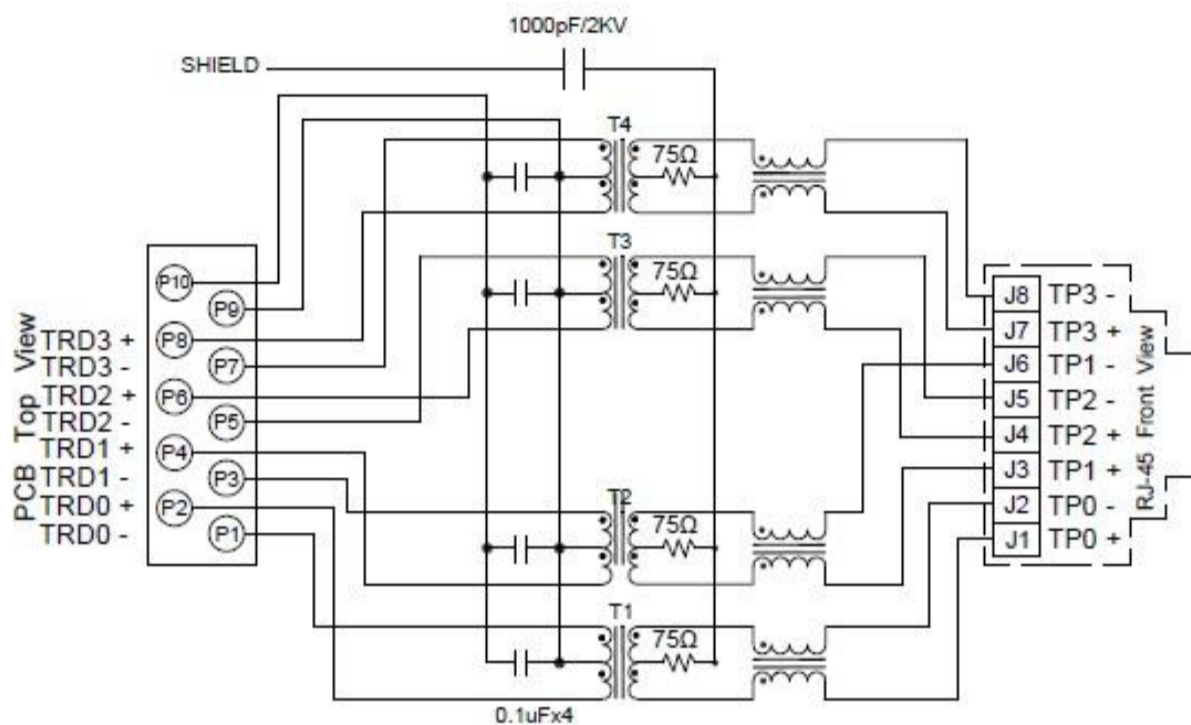

REFLOW

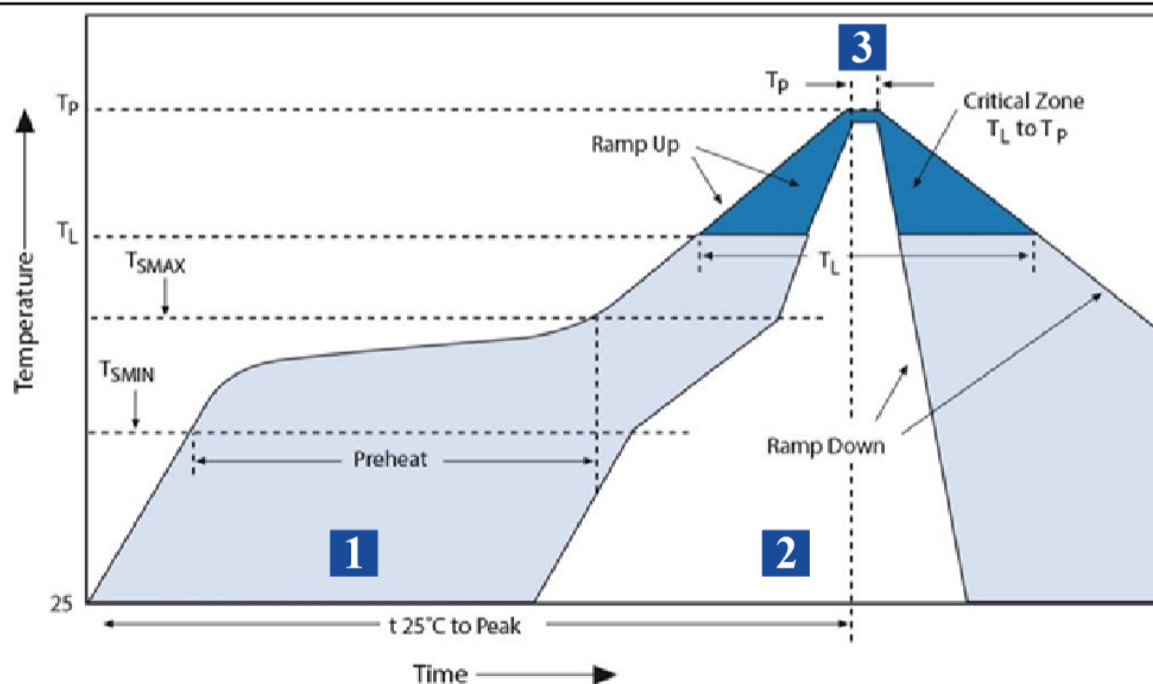

Zone	Description	Temperature	Time
1	Preheat	$T_{SMIN} - T_{SMAX}$ 160°C~180°C	120 sec.
2	Reflow	T_L 60°C	60 sec.
3	Peak Heat	T_p 260°C	10 sec. MAX

REVISED: 08/08/2016

1-PORT 100BASE-T SMD RJ45 WITH INTEGRATED MAGNETICS

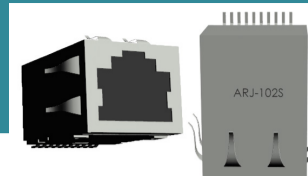

23.05 x 16.80 x 13.65mm
RoHS/RoHS II Compliant

ARJ-102S

PACKAGING

T: 54pcs/tray
Packaging material: PVC
Outer carton unit: 1512 pcs/28trays/box

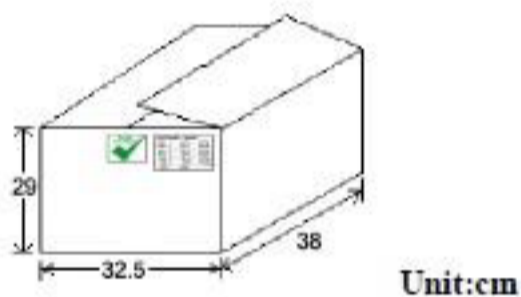
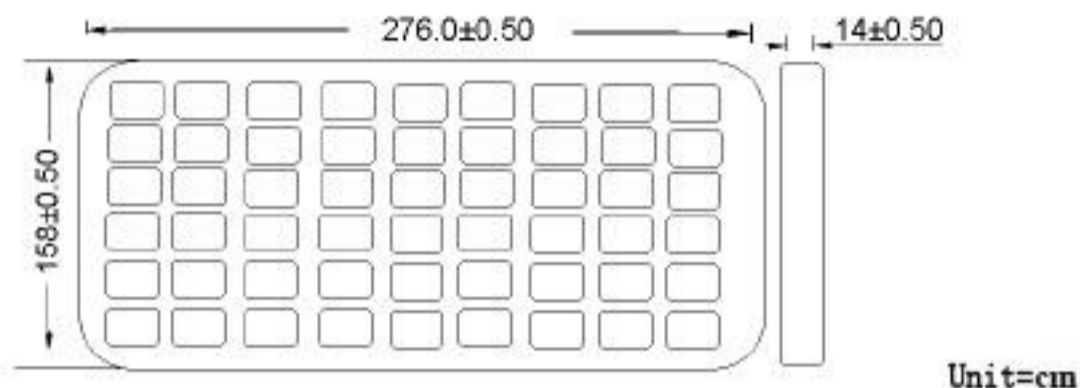

TAPE AND REEL

Weight: 6.9grams/pcs
T&R: 100pcs
Outer carton unit: 600pcs/box or 6T&R/box
Weight: 8.8kg per carton

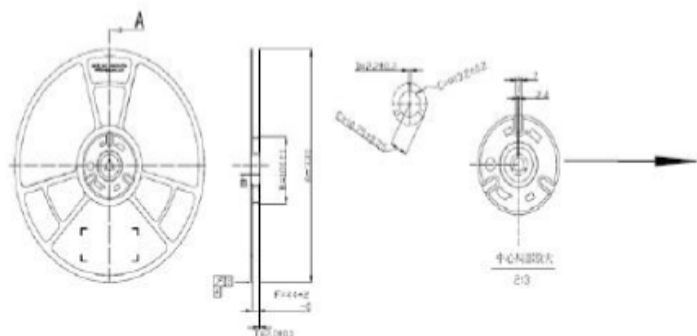
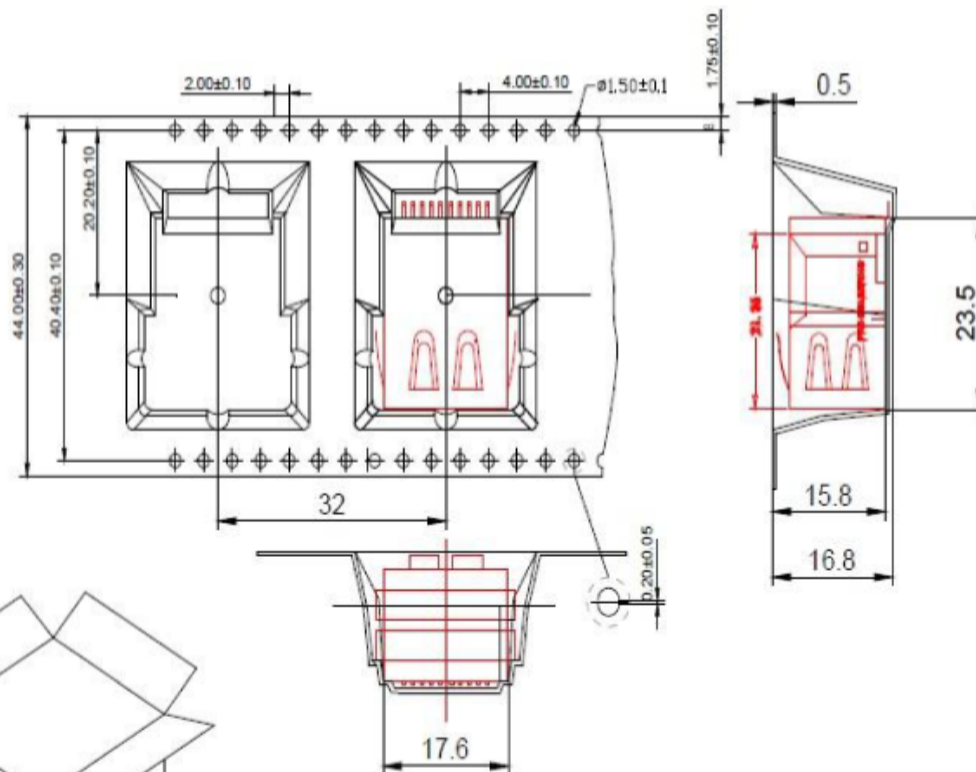

Outer carton: 365x365x350mm

REVISED: 08/08/2016