

KE04 Sub-Family Data Sheet

Supports the following:
MKE04Z8VTG4(R), MKE04Z8VWJ4(R),
and MKE04Z8VFK4(R)

Key features

- Operating characteristics
 - Voltage range: 2.7 to 5.5 V
 - Flash write voltage range: 2.7 to 5.5 V
 - Temperature range (ambient): -40 to 105°C
- Performance
 - Up to 48 MHz ARM® Cortex-M0+ core
 - Single cycle 32-bit x 32-bit multiplier
 - Single cycle I/O access port
- Memories and memory interfaces
 - Up to 8 KB flash
 - Up to 1 KB RAM
- Clocks
 - Oscillator (OSC) - supports 32.768 kHz crystal or 4 MHz to 24 MHz crystal or ceramic resonator; choice of low power or high gain oscillators
 - Internal clock source (ICS) - internal FLL with internal or external reference, 37.5 kHz pre-trimmed internal reference for 48 MHz system clock
 - Internal 1 kHz low-power oscillator (LPO)
- System peripherals
 - Power management module (PMC) with three power modes: Run, Wait, Stop
 - Low-voltage detection (LVD) with reset or interrupt, selectable trip points
 - Watchdog with independent clock source (WDOG)
 - Programmable cyclic redundancy check module (CRC)
 - Serial wire debug interface (SWD)
 - Aliased SRAM bitband region (BIT-BAND)
 - Bit manipulation engine (BME)
- Security and integrity modules
 - 80-bit unique identification (ID) number per chip
- Human-machine interface
 - Up to 22 general-purpose input/output (GPIO)
 - Two 8-bit keyboard interrupt modules (KBI)
 - External interrupt (IRQ)
- Analog modules
 - One 12-channel 12-bit SAR ADC, operation in Stop mode, optional hardware trigger (ADC)
 - Two analog comparators containing a 6-bit DAC and programmable reference input (ACMP)
- Timers
 - One 6-channel FlexTimer/PWM (FTM)
 - One 2-channel FlexTimer/PWM (FTM)
 - One 2-channel periodic interrupt timer (PIT)
 - One pulse width timer (PWT)
 - One real-time clock (RTC)
- Communication interfaces
 - One SPI module (SPI)
 - One UART module (UART)
 - One I2C module (I2C)
- Package options
 - 24-pin QFN
 - 20-pin SOIC
 - 16-pin TSSOP

MKE04P24M48SF0



Table of Contents

1	Ordering parts.....	3	5.2.2	FTM module timing.....	16
1.1	Determining valid orderable parts.....	3	5.3	Thermal specifications.....	17
2	Part identification.....	3	5.3.1	Thermal characteristics.....	17
2.1	Description.....	3	6	Peripheral operating requirements and behaviors.....	19
2.2	Format.....	3	6.1	Core modules.....	19
2.3	Fields.....	3	6.1.1	SWD electricals	19
2.4	Example.....	4	6.2	External oscillator (OSC) and ICS characteristics.....	20
3	Parameter classification.....	4	6.3	NVM specifications.....	22
4	Ratings.....	4	6.4	Analog.....	23
4.1	Thermal handling ratings.....	4	6.4.1	ADC characteristics.....	23
4.2	Moisture handling ratings.....	5	6.4.2	Analog comparator (ACMP) electricals.....	25
4.3	ESD handling ratings.....	5	6.5	Communication interfaces.....	26
4.4	Voltage and current operating ratings.....	5	6.5.1	SPI switching specifications.....	26
5	General.....	6	7	Dimensions.....	29
5.1	Nonswitching electrical specifications.....	6	7.1	Obtaining package dimensions.....	29
5.1.1	DC characteristics.....	6	8	Pinout.....	29
5.1.2	Supply current characteristics.....	13	8.1	Signal Multiplexing and Pin Assignments.....	29
5.1.3	EMC performance.....	14	8.2	Device pin assignment.....	31
5.2	Switching specifications.....	15	9	Revision history.....	32
5.2.1	Control timing.....	15			

1 Ordering parts

1.1 Determining valid orderable parts

Valid orderable part numbers are provided on the web. To determine the orderable part numbers for this device, go to freescale.com and perform a part number search for the following device numbers: KE04Z.

2 Part identification

2.1 Description

Part numbers for the chip have fields that identify the specific part. You can use the values of these fields to determine the specific part you have received.

2.2 Format

Part numbers for this device have the following format:

Q KE## A FFF R T PP CC N

2.3 Fields

This table lists the possible values for each field in the part number (not all combinations are valid):

Field	Description	Values
Q	Qualification status	<ul style="list-style-type: none"> M = Fully qualified, general market flow P = Prequalification
KE##	Kinetis family	<ul style="list-style-type: none"> KE04
A	Key attribute	<ul style="list-style-type: none"> Z = M0+ core
FFF	Program flash memory size	<ul style="list-style-type: none"> 8 = 8 KB
R	Silicon revision	<ul style="list-style-type: none"> (Blank) = Main A = Revision after main
T	Temperature range (°C)	<ul style="list-style-type: none"> V = -40 to 105
PP	Package identifier	<ul style="list-style-type: none"> TG = 16 TSSOP (4.5 mm x 5 mm)

Table continues on the next page...

Parameter classification

Field	Description	Values
		<ul style="list-style-type: none"> WJ = 20 SOIC (7 mm x 12 mm) FK = 24 QFN (4 mm x 4 mm)
CC	Maximum CPU frequency (MHz)	<ul style="list-style-type: none"> 4 = 48 MHz
N	Packaging type	<ul style="list-style-type: none"> R = Tape and reel (Blank) = Trays

2.4 Example

This is an example part number:

MKE04Z8VFK4

3 Parameter classification

The electrical parameters shown in this supplement are guaranteed by various methods. To give the customer a better understanding, the following classification is used and the parameters are tagged accordingly in the tables where appropriate:

Table 1. Parameter classifications

P	Those parameters are guaranteed during production testing on each individual device.
C	Those parameters are achieved by the design characterization by measuring a statistically relevant sample size across process variations.
T	Those parameters are achieved by design characterization on a small sample size from typical devices under typical conditions unless otherwise noted. All values shown in the typical column are within this category.
D	Those parameters are derived mainly from simulations.

NOTE

The classification is shown in the column labeled “C” in the parameter tables where appropriate.

4 Ratings

4.1 Thermal handling ratings

Symbol	Description	Min.	Max.	Unit	Notes
T _{STG}	Storage temperature	-55	150	°C	1

Table continues on the next page...

Symbol	Description	Min.	Max.	Unit	Notes
T _{SDR}	Solder temperature, lead-free	—	260	°C	2

1. Determined according to JEDEC Standard JESD22-A103, *High Temperature Storage Life*.
2. Determined according to IPC/JEDEC Standard J-STD-020, *Moisture/Reflow Sensitivity Classification for Nonhermetic Solid State Surface Mount Devices*.

4.2 Moisture handling ratings

Symbol	Description	Min.	Max.	Unit	Notes
MSL	Moisture sensitivity level	—	3	—	1

1. Determined according to IPC/JEDEC Standard J-STD-020, *Moisture/Reflow Sensitivity Classification for Nonhermetic Solid State Surface Mount Devices*.

4.3 ESD handling ratings

Symbol	Description	Min.	Max.	Unit	Notes
V _{HBM}	Electrostatic discharge voltage, human body model	−6000	+6000	V	1
V _{CDM}	Electrostatic discharge voltage, charged-device model	−500	+500	V	2
I _{LAT}	Latch-up current at ambient temperature of °C	−100	+100	mA	3

1. Determined according to JEDEC Standard JESD22-A114, *Electrostatic Discharge (ESD) Sensitivity Testing Human Body Model (HBM)*.
2. Determined according to JEDEC Standard JESD22-C101, *Field-Induced Charged-Device Model Test Method for Electrostatic-Discharge-Withstand Thresholds of Microelectronic Components*.
3. Determined according to JEDEC Standard JESD78D, *IC Latch-up Test*.
 - Test was performed at 105 °C case temperature (Class II).
 - I/O pins pass ±100 mA I-test with I_{DD} current limit at 200 mA.
 - I/O pins pass +30/-100 mA I-test with I_{DD} current limit at 1000 mA.
 - Supply groups pass 1.5 V_{ccmax}.
 - RESET pin was only tested with negative I-test due to product conditioning requirement.

4.4 Voltage and current operating ratings

Absolute maximum ratings are stress ratings only, and functional operation at the maxima is not guaranteed. Stress beyond the limits specified in the following table may affect device reliability or cause permanent damage to the device. For functional operating conditions, refer to the remaining tables in this document.

This device contains circuitry protecting against damage due to high static voltage or electrical fields; however, it is advised that normal precautions be taken to avoid application of any voltages higher than maximum-rated voltages to this high-impedance

circuit. Reliability of operation is enhanced if unused inputs are tied to an appropriate logic voltage level (for instance, either V_{SS} or V_{DD}) or the programmable pullup resistor associated with the pin is enabled.

Table 2. Voltage and current operating ratings

Symbol	Description	Min.	Max.	Unit
V_{DD}	Digital supply voltage	-0.3	6.0	V
I_{DD}	Maximum current into V_{DD}	—	120	mA
V_{IN}	Input voltage except true open drain pins	-0.3	$V_{DD} + 0.3$ ¹	V
	Input voltage of true open drain pins	-0.3	6	V
I_D	Instantaneous maximum current single pin limit (applies to all port pins)	-25	25	mA
V_{DDA}	Analog supply voltage	$V_{DD} - 0.3$	$V_{DD} + 0.3$	V

1. Maximum rating of V_{DD} also applies to V_{IN} .

5 General

5.1 Nonswitching electrical specifications

5.1.1 DC characteristics

This section includes information about power supply requirements and I/O pin characteristics.

Table 3. DC characteristics

Symbol	C	Descriptions		Min	Typical ¹	Max	Unit
—	—	Operating voltage		—	2.7	—	5.5 V
V_{OH}	P	Output high voltage	All I/O pins, except PTA2 and PTA3, standard-drive strength	5 V, $I_{load} = -5$ mA	$V_{DD} - 0.8$	—	— V
	C			3 V, $I_{load} = -2.5$ mA	$V_{DD} - 0.8$	—	— V
	P		High current drive pins, high-drive strength ²	5 V, $I_{load} = -20$ mA	$V_{DD} - 0.8$	—	— V
	C			3 V, $I_{load} = -10$ mA	$V_{DD} - 0.8$	—	— V
I_{OHT}	D	Output high current	Max total I_{OH} for all ports	5 V	—	—	-100 mA
				3 V	—	—	-60
V_{OL}	P	Output low voltage	All I/O pins, standard-drive strength	5 V, $I_{load} = 5$ mA	—	—	0.8 V
	C			3 V, $I_{load} = 2.5$ mA	—	—	0.8 V
	P		High current drive pins, high-drive strength ²	5 V, $I_{load} = 20$ mA	—	—	0.8 V
	C			3 V, $I_{load} = 10$ mA	—	—	0.8 V

Table continues on the next page...

Table 3. DC characteristics (continued)

Symbol	C	Descriptions		Min	Typical ¹	Max	Unit	
I _{OLT}	D	Output low current	Max total I _{OL} for all ports	5 V	—	—	100	mA
				3 V	—	—	60	
V _{IH}	P	Input high voltage	All digital inputs	4.5 ≤ V _{DD} < 5.5 V	0.65 × V _{DD}	—	—	V
				2.7 ≤ V _{DD} < 4.5 V	0.70 × V _{DD}	—	—	
V _{IL}	P	Input low voltage	All digital inputs	4.5 ≤ V _{DD} < 5.5 V	—	—	0.35 × V _{DD}	V
				2.7 ≤ V _{DD} < 4.5 V	—	—	0.30 × V _{DD}	
V _{hys}	C	Input hysteresis	All digital inputs	—	0.06 × V _{DD}	—	—	mV
I _{In}	P	Input leakage current	Per pin (pins in high impedance input mode)	V _{IN} = V _{DD} or V _{SS}	—	0.1	1	μA
I _{INTOT}	C	Total leakage combined for all port pins	Pins in high impedance input mode	V _{IN} = V _{DD} or V _{SS}	—	—	2	μA
R _{PU}	P	Pullup resistors	All digital inputs, when enabled (all I/O pins other than PTA2 and PTA3)	—	30.0	—	50.0	kΩ
R _{PU} ³	P	Pullup resistors	PTA2 and PTA3 pins	—	30.0	—	60.0	kΩ
I _{IC}	D	DC injection current ^{4, 5, 6}	Single pin limit	V _{IN} < V _{SS} , V _{IN} > V _{DD}	-2	—	2	mA
			Total MCU limit, includes sum of all stressed pins		-5	—	25	
C _{In}	C	Input capacitance, all pins		—	—	—	7	pF
V _{RAM}	C	RAM retention voltage		—	2.0	—	—	V

1. Typical values are measured at 25 °C. Characterized, not tested.
2. Only PTB5, PTC1 and PTC5 support high current output.
3. The specified resistor value is the actual value internal to the device. The pullup value may appear higher when measured externally on the pin.
4. All functional non-supply pins, except for PTA2 and PTA3, are internally clamped to V_{SS} and V_{DD}. PTA2 and PTA3 are true open drain I/O pins that are internally clamped to V_{SS}.
5. Input must be current limited to the value specified. To determine the value of the required current-limiting resistor, calculate resistance values for positive and negative clamp voltages, then use the larger value.
6. Power supply must maintain regulation within operating V_{DD} range during instantaneous and operating maximum current conditions. If the positive injection current (V_{in} > V_{DD}) is higher than I_{DD}, the injection current may flow out of V_{DD} and could result in external power supply going out of regulation. Ensure that external V_{DD} load will shunt current higher than maximum injection current when the MCU is not consuming power, such as when no system clock is present, or clock rate is very low (which would reduce overall power consumption).

Table 4. LVD and POR specification

Symbol	C	Description	Min	Typ	Max	Unit	
V _{POR}	D	POR re-arm voltage ¹	1.5	1.75	2.0	V	
V _{LVDH}	C	Falling low-voltage detect threshold—high range (LVDV = 1) ²	4.2	4.3	4.4	V	
V _{LW1H}	C	Falling low-voltage warning threshold—high range	Level 1 falling (LVWV = 00)	4.3	4.4	4.5	V
V _{LW2H}	C		Level 2 falling (LVWV = 01)	4.5	4.5	4.6	V
V _{LW3H}	C		Level 3 falling (LVWV = 10)	4.6	4.6	4.7	V
V _{LW4H}	C		Level 4 falling (LVWV = 11)	4.7	4.7	4.8	V
V _{HYSH}	C	High range low-voltage detect/warning hysteresis	—	100	—	mV	
V _{LVDL}	C	Falling low-voltage detect threshold—low range (LVDV = 0)	2.56	2.61	2.66	V	
V _{LW1L}	C	Falling low-voltage warning threshold—low range	Level 1 falling (LVWV = 00)	2.62	2.7	2.78	V
V _{LW2L}	C		Level 2 falling (LVWV = 01)	2.72	2.8	2.88	V
V _{LW3L}	C		Level 3 falling (LVWV = 10)	2.82	2.9	2.98	V
V _{LW4L}	C		Level 4 falling (LVWV = 11)	2.92	3.0	3.08	V
V _{HYSDL}	C	Low range low-voltage detect hysteresis	—	40	—	mV	
V _{HYSWL}	C	Low range low-voltage warning hysteresis	—	80	—	mV	
V _{BG}	P	Buffered bandgap output ³	1.14	1.16	1.18	V	

1. Maximum is highest voltage that POR is guaranteed.
2. Rising thresholds are falling threshold + hysteresis.
3. voltage Factory trimmed at V_{DD} = 5.0 V, Temp = 25 °C

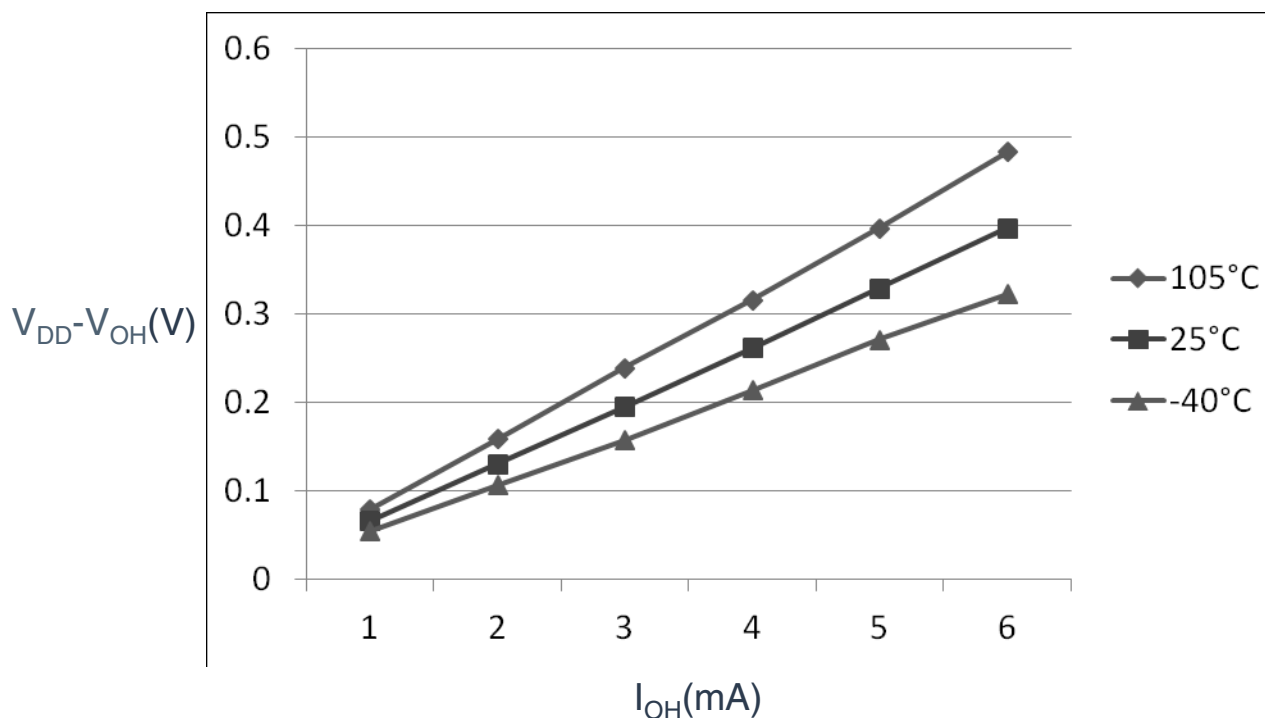

Figure 1. Typical $V_{DD}-V_{OH}$ Vs. I_{OH} (standard drive strength) ($V_{DD} = 5V$)

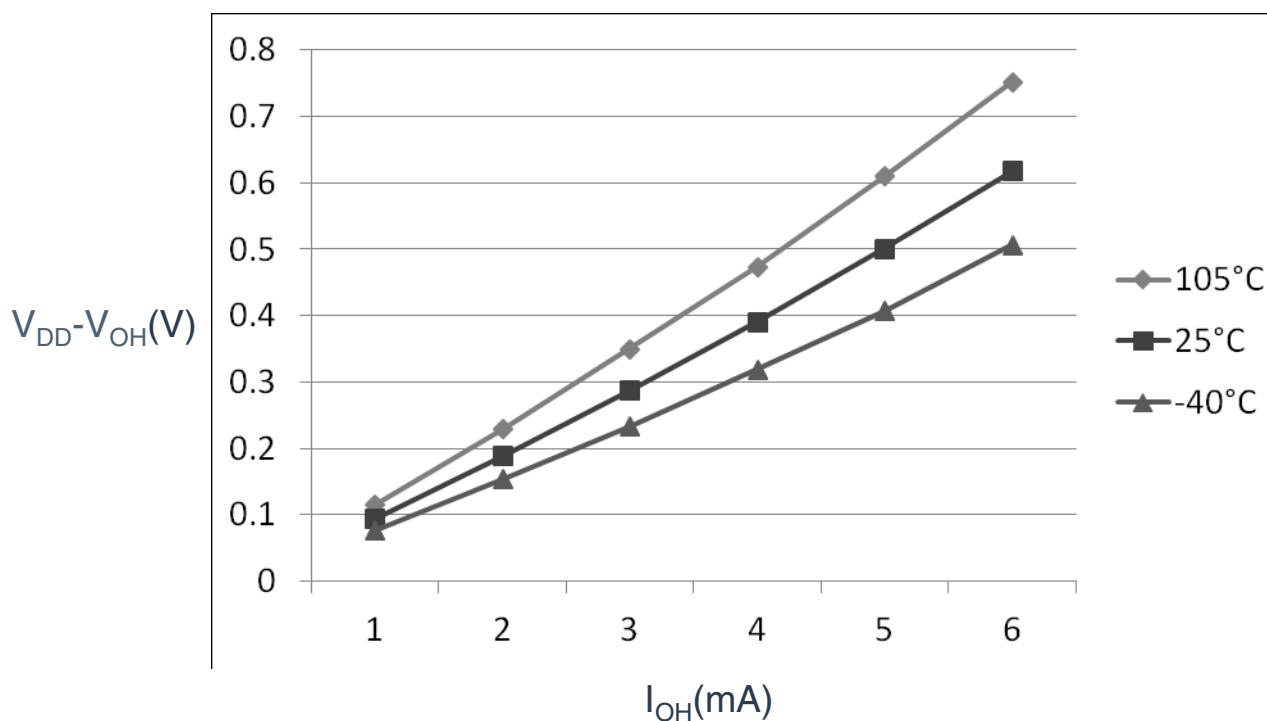

Figure 2. Typical $V_{DD}-V_{OH}$ Vs. I_{OH} (standard drive strength) ($V_{DD} = 3V$)

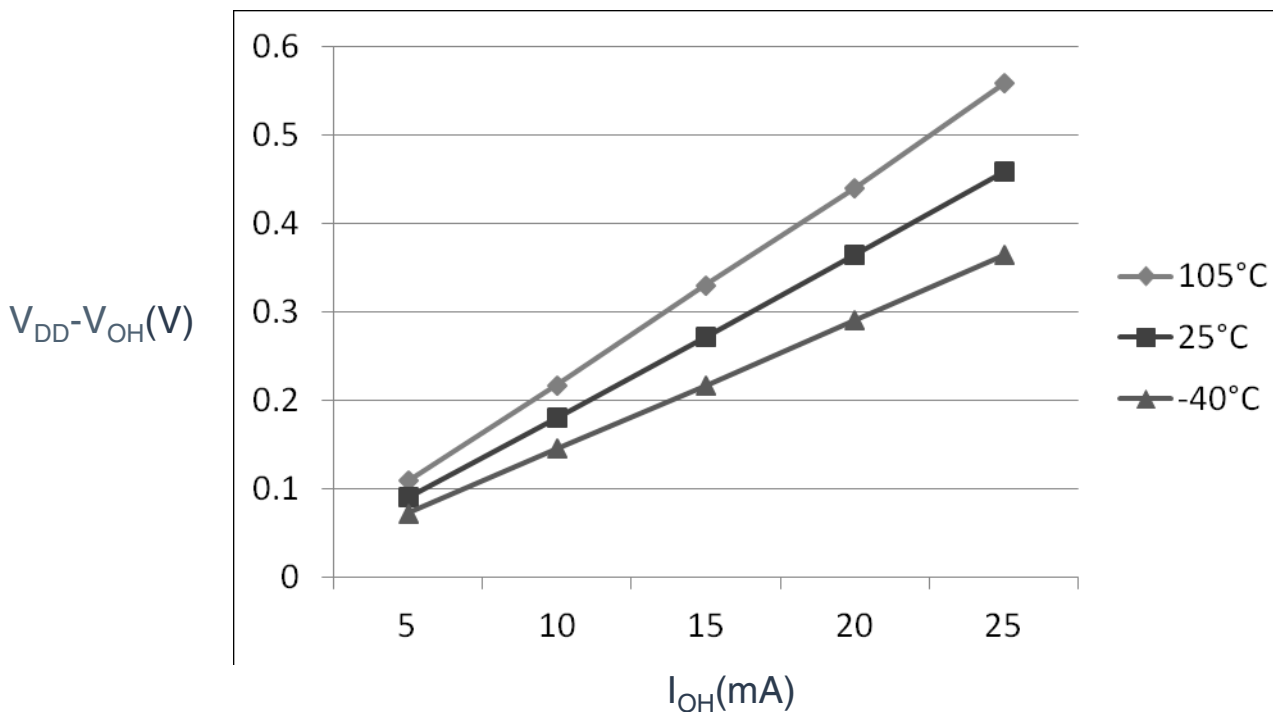

Figure 3. Typical $V_{DD}-V_{OH}$ Vs. I_{OH} (high drive strength) ($V_{DD} = 5V$)

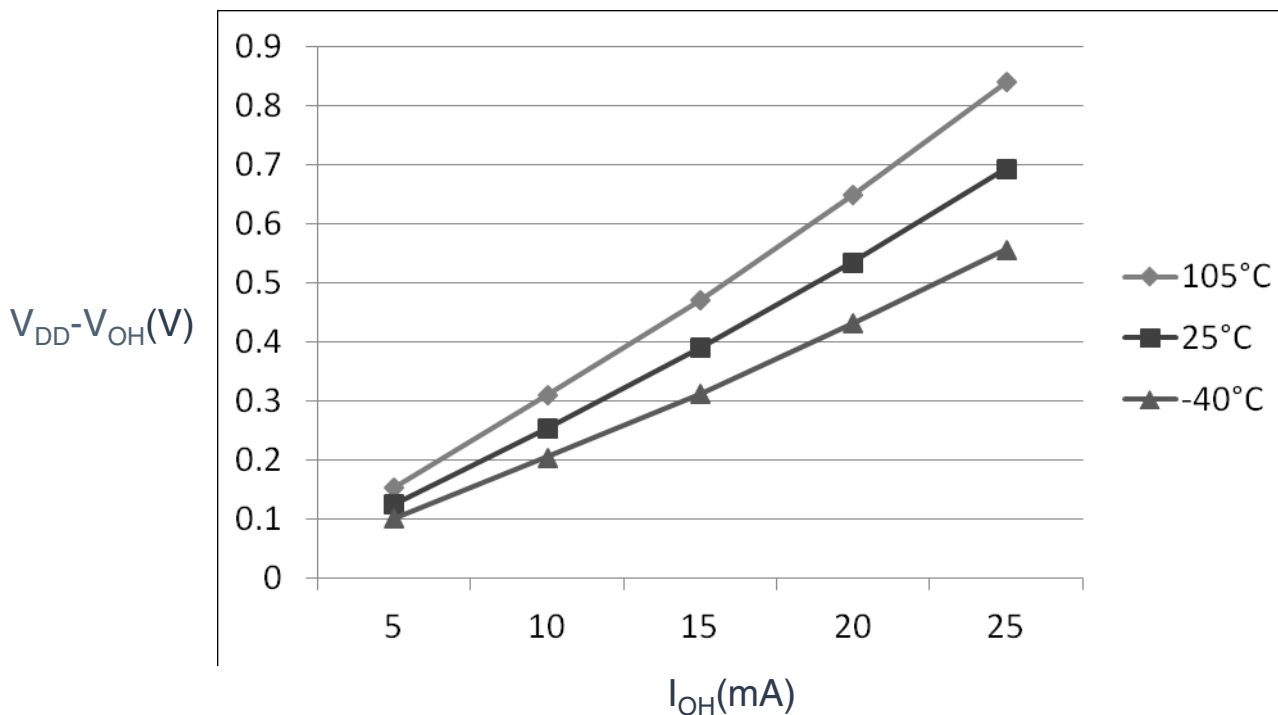

Figure 4. Typical $V_{DD}-V_{OH}$ Vs. I_{OH} (high drive strength) ($V_{DD} = 3V$)

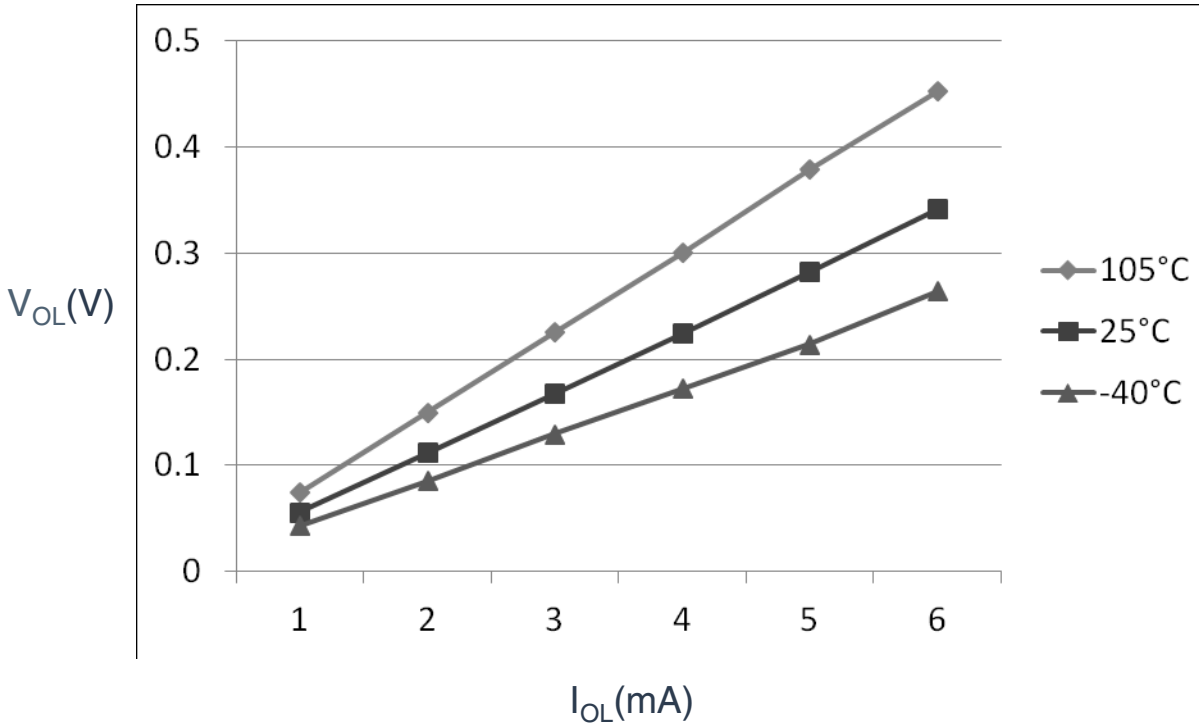

Figure 5. Typical V_{OL} Vs. I_{OL} (standard drive strength) ($V_{DD} = 5\text{ V}$)

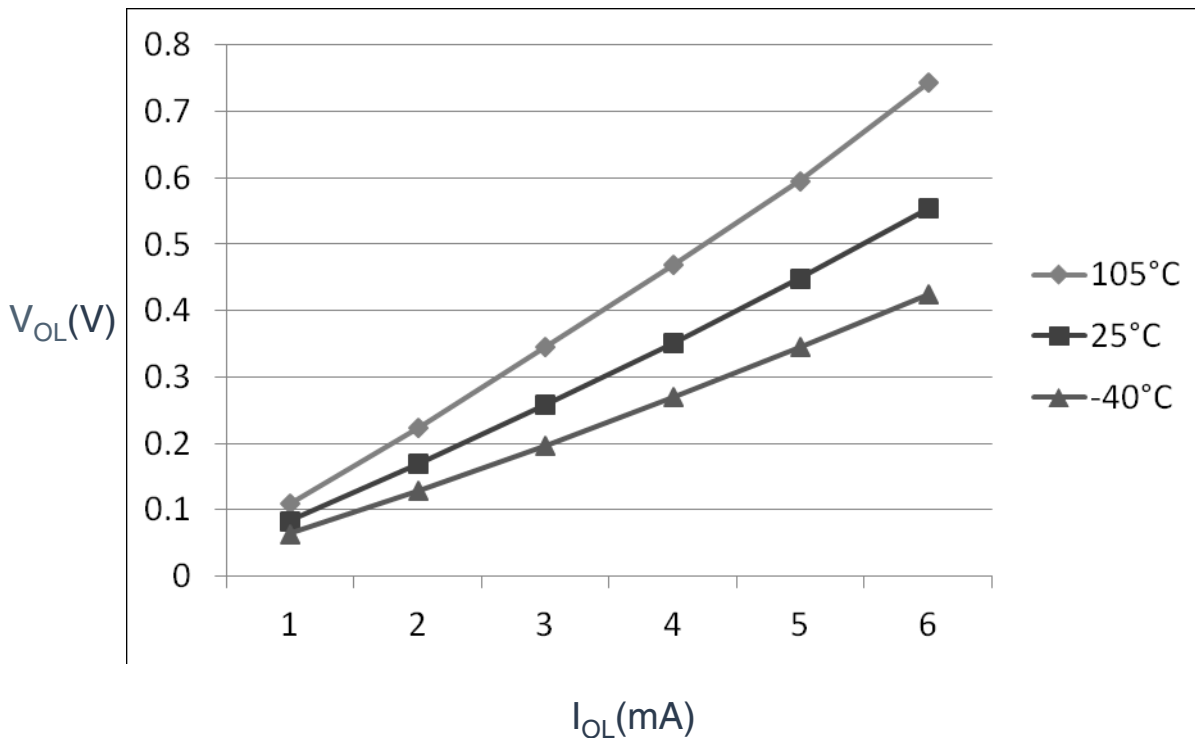

Figure 6. Typical V_{OL} Vs. I_{OL} (standard drive strength) ($V_{DD} = 3\text{ V}$)

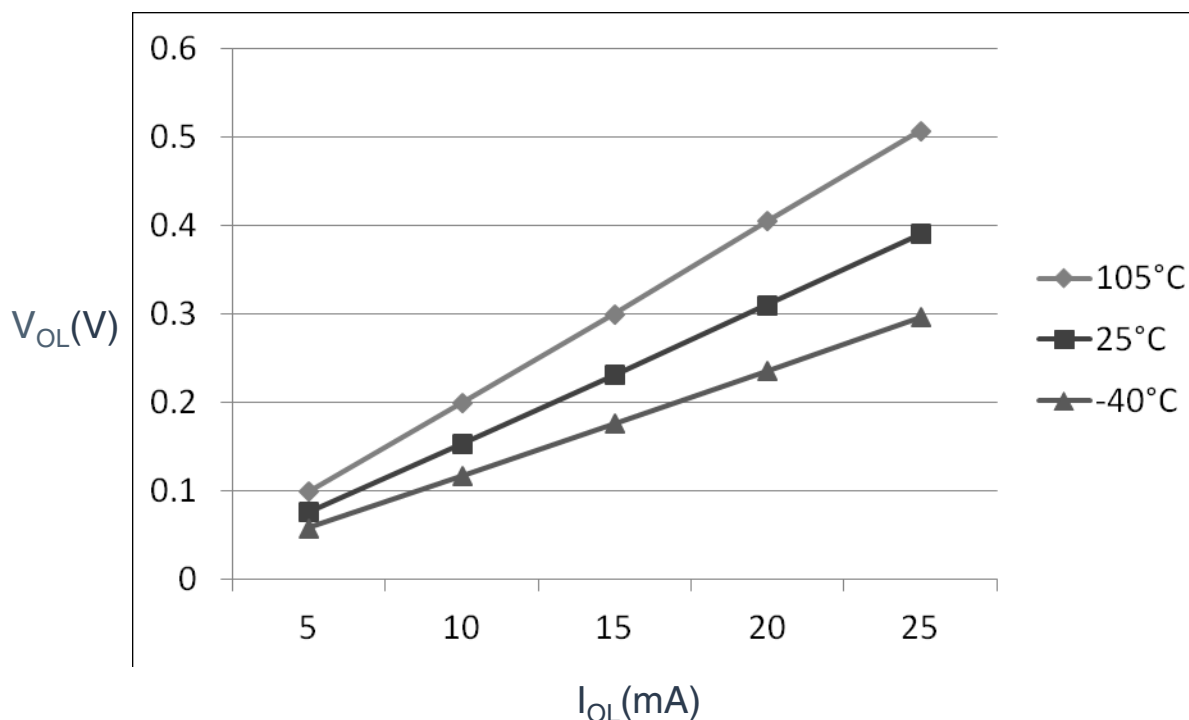

Figure 7. Typical V_{OL} Vs. I_{OL} (high drive strength) ($V_{DD} = 5\text{ V}$)

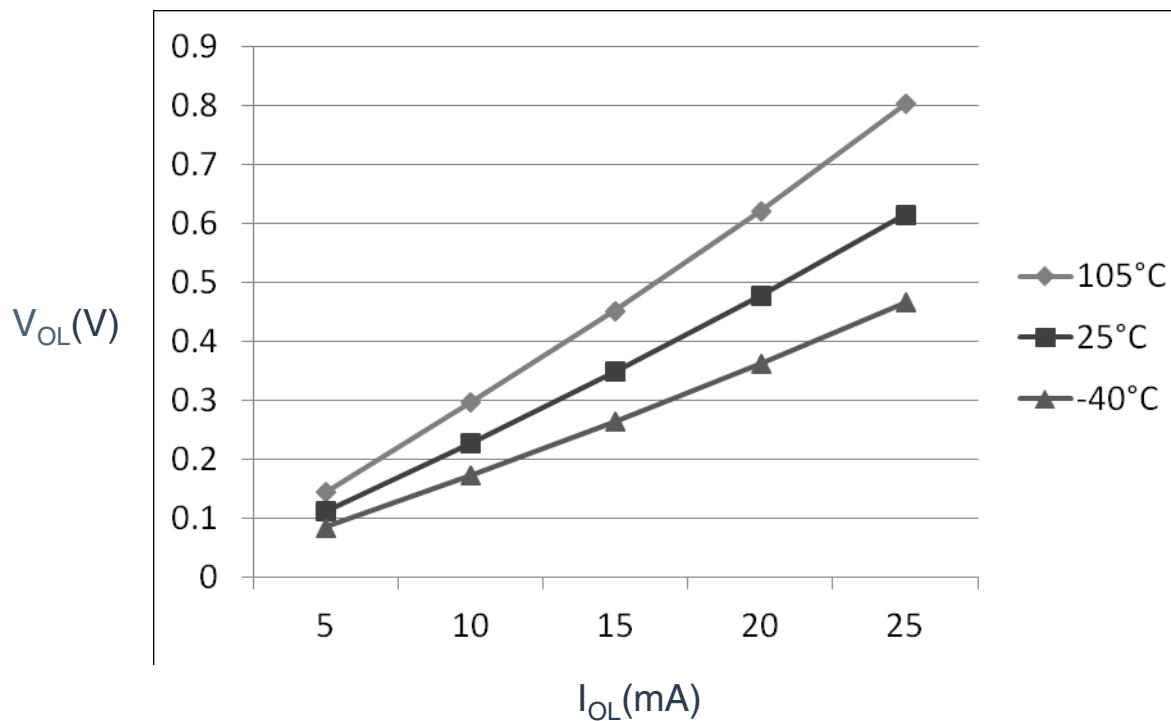

Figure 8. Typical V_{OL} Vs. I_{OL} (high drive strength) ($V_{DD} = 3\text{ V}$)

5.1.2 Supply current characteristics

This section includes information about power supply current in various operating modes.

Table 5. Supply current characteristics

C	Parameter	Symbol	Core/Bus Freq	V _{DD} (V)	Typical ¹	Max ²	Unit	Temp
C	Run supply current FEI mode, all modules clocks enabled; run from flash	R _{IDD}	48/24 MHz	5	10.1	—	mA	-40 to 105 °C
C			24/24 MHz		7.1	—		
C			12/12 MHz		4.4	—		
C			1/1 MHz		2.1	—		
C			48/24 MHz	3	9.9	—		
C			24/24 MHz		6.9	—		
C			12/12 MHz		4.2	—		
C			1/1 MHz		1.9	—		
C	Run supply current FEI mode, all modules clocks disabled and gated; run from flash	R _{IDD}	48/24 MHz	5	7.4	—	mA	-40 to 105 °C
C			24/24 MHz		5.2	—		
C			12/12 MHz		3.5	—		
C			1/1 MHz		2	—		
C			48/24 MHz	3	7.2	—		
C			24/24 MHz		5	—		
C			12/12 MHz		3.3	—		
C			1/1 MHz		1.8	—		
C	Run supply current FBE mode, all modules clocks enabled; run from RAM	R _{IDD}	48/24 MHz	5	13.2	—	mA	-40 to 105 °C
P			24/24 MHz		9.1	9.5		
C			12/12 MHz		5.1	—		
C			1/1 MHz		1.8	—		
C			48/24 MHz	3	13	—		
P			24/24 MHz		9	9.4		
C			12/12 MHz		5	—		
C			1/1 MHz		1.7	—		
C	Run supply current FBE mode, all modules clocks disabled and gated; run from RAM	R _{IDD}	48/24 MHz	5	10.6	—	mA	-40 to 105 °C
P			24/24 MHz		7.6	7.8		
C			12/12 MHz		4.3	—		
C			1/1 MHz		1.7	—		
C			48/24 MHz	3	10.5	—		
P			24/24 MHz		7.5	7.7		
C			12/12 MHz		4.2	—		
C			1/1 MHz		1.6	—		

Table continues on the next page...

Table 5. Supply current characteristics (continued)

C	Parameter	Symbol	Core/Bus Freq	V _{DD} (V)	Typical ¹	Max ²	Unit	Temp
C	Wait mode current FEI mode, all modules clocks enabled	W _{IDD}	48/24 MHz	5	7.2	—	mA	-40 to 105 °C
P			24/24 MHz		6.3	6.5		
C			12/12 MHz		3.6	—		
C			1/1 MHz		1.9	—		
C			48/24 MHz	3	7.1	—		
P			24/24 MHz		6.2	6.4		
C			12/12 MHz		3.5	—		
C			1/1 MHz		1.8	—		
P	Stop mode supply current no clocks active (except 1 kHz LPO clock) ³	S _{IDD}	—	5	2	40	μA	-40 to 105 °C
P			—	3	1.9	39		-40 to 105 °C
C	ADC adder to Stop	—	—	5	86	—	μA	-40 to 105 °C
C	ADLPC = 1 ADLSMP = 1 ADCO = 1 MODE = 10B ADICLK = 11B	—	—	3	82	—		
C	ACMP adder to Stop	—	—	5	12	—	μA	-40 to 105 °C
C				3	12	—		
C	LVD adder to Stop ⁴	—	—	5	130	—	μA	-40 to 105 °C
C				3	125	—		

1. Data in Typical column was characterized at 5.0 V, 25 °C or is typical recommended value.
2. The Max current is observed at high temperature of 105 °C.
3. RTC adder cause <1 μA I_{DD} increase typically, RTC clock source is 1 kHz LPO clock.
4. LVD is periodically woken up from Stop by 5% duty cycle. The period is equal to or less than 2 ms.

5.1.3 EMC performance

Electromagnetic compatibility (EMC) performance is highly dependent on the environment in which the MCU resides. Board design and layout, circuit topology choices, location and characteristics of external components as well as MCU software operation play a significant role in EMC performance. The system designer must consult the following Freescale applications notes, available on freescale.com for advice and guidance specifically targeted at optimizing EMC performance.

- AN2321: Designing for Board Level Electromagnetic Compatibility
- AN1050: Designing for Electromagnetic Compatibility (EMC) with HCMOS Microcontrollers
- AN1263: Designing for Electromagnetic Compatibility with Single-Chip Microcontrollers

- AN2764: Improving the Transient Immunity Performance of Microcontroller-Based Applications
- AN1259: System Design and Layout Techniques for Noise Reduction in MCU-Based Systems

5.1.3.1 EMC radiated emissions operating behaviors

Table 6. EMC radiated emissions operating behaviors for 20-pin SOIC package

Symbol	Description	Frequency band (MHz)	Typ.	Unit	Notes
V_{RE1}	Radiated emissions voltage, band 1	0.15–50	11	dB μ V	1, 2
V_{RE2}	Radiated emissions voltage, band 2	50–150	14	dB μ V	
V_{RE3}	Radiated emissions voltage, band 3	150–500	11	dB μ V	
V_{RE4}	Radiated emissions voltage, band 4	500–1000	5	dB μ V	
V_{RE_IEC}	IEC level	0.15–1000	M	—	2, 3

1. Determined according to IEC Standard 61967-1, *Integrated Circuits - Measurement of Electromagnetic Emissions, 150 kHz to 1 GHz Part 1: General Conditions and Definitions* and IEC Standard 61967-2, *Integrated Circuits - Measurement of Electromagnetic Emissions, 150 kHz to 1 GHz Part 2: Measurement of Radiated Emissions—TEM Cell and Wideband TEM Cell Method*. Measurements were made while the microcontroller was running basic application code. The reported emission level is the value of the maximum measured emission, rounded up to the next whole number, from among the measured orientations in each frequency range.
2. $V_{DD} = 5.0$ V, $T_A = 25$ °C, $f_{OSC} = 8$ MHz (crystal), $f_{SYS} = 40$ MHz, $f_{BUS} = 20$ MHz
3. Specified according to Annex D of IEC Standard 61967-2, *Measurement of Radiated Emissions—TEM Cell and Wideband TEM Cell Method*

5.2 Switching specifications

5.2.1 Control timing

Table 7. Control timing

Num	C	Rating	Symbol	Min	Typical ¹	Max	Unit
1	D	System and core clock	f_{SYS}	DC	—	48	MHz
2	P	Bus frequency ($t_{cyc} = 1/f_{BUS}$)	f_{BUS}	DC	—	24	MHz
3	P	Internal low power oscillator frequency	f_{LPO}	0.67	1.0	1.25	KHz
4	D	External reset pulse width ²	t_{extrst}	$1.5 \times t_{cyc}$	—	—	ns
5	D	Reset low drive	t_{rstdrv}	$34 \times t_{cyc}$	—	—	ns
6	D	IRQ pulse width	Asynchronous path ²	t_{LIH}	100	—	ns
	D		Synchronous path ³	t_{IHIL}	$1.5 \times t_{cyc}$	—	ns

Table continues on the next page...

Table 7. Control timing (continued)

Num	C	Rating	Symbol	Min	Typical ¹	Max	Unit
7	D	Keyboard interrupt pulse width	Asynchronous path ²	t_{LIH}	100	—	ns
	D		Synchronous path	t_{HIL}	$1.5 \times t_{cyc}$	—	ns
8	C	Port rise and fall time - Normal drive strength (load = 50 pF) ⁴	—	t_{Rise}	—	10.2	ns
	C		—	t_{Fall}	—	9.5	ns
	C	Port rise and fall time - high drive strength (load = 50 pF) ⁴	—	t_{Rise}	—	5.4	ns
	C		—	t_{Fall}	—	4.6	ns

1. Typical values are based on characterization data at $V_{DD} = 5.0\text{ V}$, $25\text{ }^\circ\text{C}$ unless otherwise stated.
2. This is the shortest pulse that is guaranteed to be recognized as a RESET pin request.
3. This is the minimum pulse width that is guaranteed to pass through the pin synchronization circuitry. Shorter pulses may or may not be recognized. In stop mode, the synchronizer is bypassed so shorter pulses can be recognized.
4. Timing is shown with respect to 20% V_{DD} and 80% V_{DD} levels. Temperature range $-40\text{ }^\circ\text{C}$ to $105\text{ }^\circ\text{C}$.

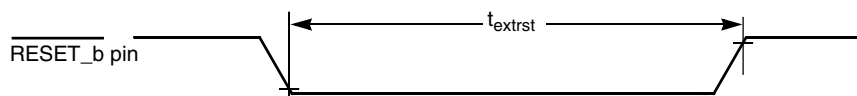

Figure 9. Reset timing

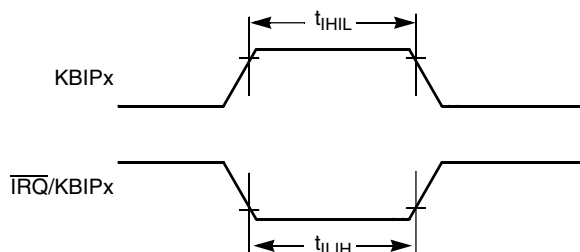

Figure 10. KBIPx timing

5.2.2 FTM module timing

Synchronizer circuits determine the shortest input pulses that can be recognized or the fastest clock that can be used as the optional external source to the timer counter.

Table 8. FTM input timing

C	Function	Symbol	Min	Max	Unit
D	Timer clock frequency	f_{Timer}	f_{Bus}	f_{Sys}	Hz
D	External clock frequency	f_{TCLK}	0	$f_{Timer}/4$	Hz
D	External clock period	t_{TCLK}	4	—	t_{cyc}

Table continues on the next page...

Table 8. FTM input timing (continued)

C	Function	Symbol	Min	Max	Unit
D	External clock high time	t_{clkh}	1.5	—	t_{cyc}
D	External clock low time	t_{clkl}	1.5	—	t_{cyc}
D	Input capture pulse width	t_{ICPW}	1.5	—	t_{cyc}

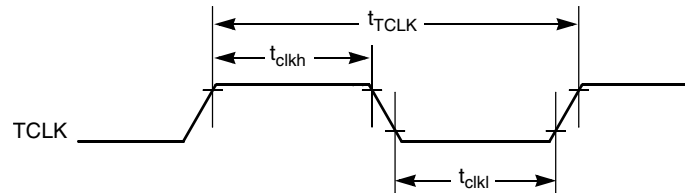
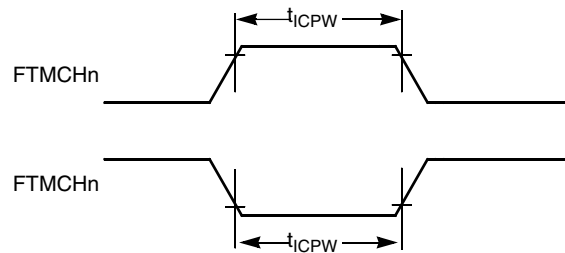
Figure 11. Timer external clock

Figure 12. Timer input capture pulse

5.3 Thermal specifications

5.3.1 Thermal characteristics

This section provides information about operating temperature range, power dissipation, and package thermal resistance. Power dissipation on I/O pins is usually small compared to the power dissipation in on-chip logic and voltage regulator circuits, and it is user-determined rather than being controlled by the MCU design. To take $P_{I/O}$ into account in power calculations, determine the difference between actual pin voltage and V_{SS} or V_{DD} and multiply by the pin current for each I/O pin. Except in cases of unusually high pin current (heavy loads), the difference between pin voltage and V_{SS} or V_{DD} will be very small.

Table 9. Thermal attributes

Board type	Symbol	Description	24 QFN	20 SOIC	16 TSSOP	Unit	Notes
Single-layer (1S)	R _{θJA}	Thermal resistance, junction to ambient (natural convection)	110	88	130	°C/W	1, 2
Four-layer (2s2p)	R _{θJA}	Thermal resistance, junction to ambient (natural convection)	42	61	87	°C/W	1, 3
Single-layer (1S)	R _{θJMA}	Thermal resistance, junction to ambient (200 ft./min. air speed)	92	74	109	°C/W	1, 3
Four-layer (2s2p)	R _{θJMA}	Thermal resistance, junction to ambient (200 ft./min. air speed)	36	55	80	°C/W	1, 3
—	R _{θJB}	Thermal resistance, junction to board	18	34	48	°C/W	4
—	R _{θJC}	Thermal resistance, junction to case	3.7	37	33	°C/W	5
—	Ψ _{JT}	Thermal characterization parameter, junction to package top outside center (natural convection)	10	20	10	°C/W	6

1. Junction temperature is a function of die size, on-chip power dissipation, package thermal resistance, mounting site (board) temperature, ambient temperature, air flow, power dissipation of other components on the board, and board thermal resistance.
2. Per JEDEC JESD51-2 with the single layer board (JESD51-3) horizontal.
3. Per JEDEC JESD51-6 with the board (JESD51-7) horizontal.
4. Thermal resistance between the die and the printed circuit board per JEDEC JESD51-8. Board temperature is measured on the top surface of the board near the package.
5. Thermal resistance between the die and the solder pad on the bottom of the package. Interface resistance is ignored.
6. Thermal characterization parameter indicating the temperature difference between package top and the junction temperature per JEDEC JESD51-2. When Greek letters are not available, the thermal characterization.

The average chip-junction temperature (T_J) in °C can be obtained from:

$$T_J = T_A + (P_D \times \theta_{JA})$$

Where:

T_A = Ambient temperature, °C

θ_{JA} = Package thermal resistance, junction-to-ambient, °C/W

$$P_D = P_{int} + P_{I/O}$$

P_{int} = I_{DD} × V_{DD}, Watts - chip internal power

P_{I/O} = Power dissipation on input and output pins - user determined

For most applications, P_{I/O} << P_{int} and can be neglected. An approximate relationship between P_D and T_J (if P_{I/O} is neglected) is:

$$P_D = K \div (T_J + 273 \text{ } ^\circ\text{C})$$

Solving the equations above for K gives:

$$K = P_D \times (T_A + 273 \text{ }^\circ\text{C}) + \theta_{JA} \times (P_D)^2$$

where K is a constant pertaining to the particular part. K can be determined by measuring P_D (at equilibrium) for an known T_A . Using this value of K, the values of P_D and T_J can be obtained by solving the above equations iteratively for any value of T_A .

6 Peripheral operating requirements and behaviors

6.1 Core modules

6.1.1 SWD electricals

Table 10. SWD full voltage range electricals

Symbol	Description	Min.	Max.	Unit
	Operating voltage	2.7	5.5	V
J1	SWD_CLK frequency of operation <ul style="list-style-type: none"> Serial wire debug 	0	24	MHz
J2	SWD_CLK cycle period	1/J1	—	ns
J3	SWD_CLK clock pulse width <ul style="list-style-type: none"> Serial wire debug 	20	—	ns
J4	SWD_CLK rise and fall times	—	3	ns
J9	SWD_DIO input data setup time to SWD_CLK rise	10	—	ns
J10	SWD_DIO input data hold time after SWD_CLK rise	3	—	ns
J11	SWD_CLK high to SWD_DIO data valid	—	35	ns
J12	SWD_CLK high to SWD_DIO high-Z	5	—	ns

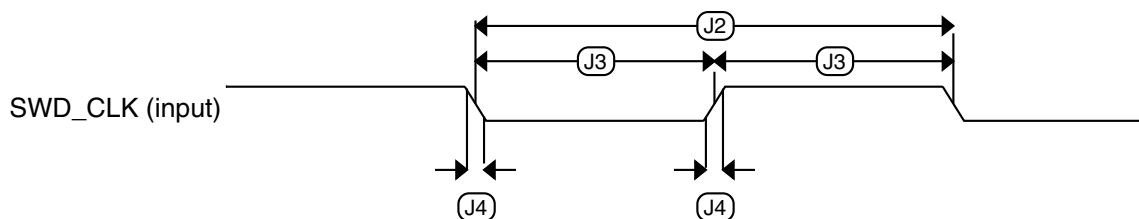

Figure 13. Serial wire clock input timing

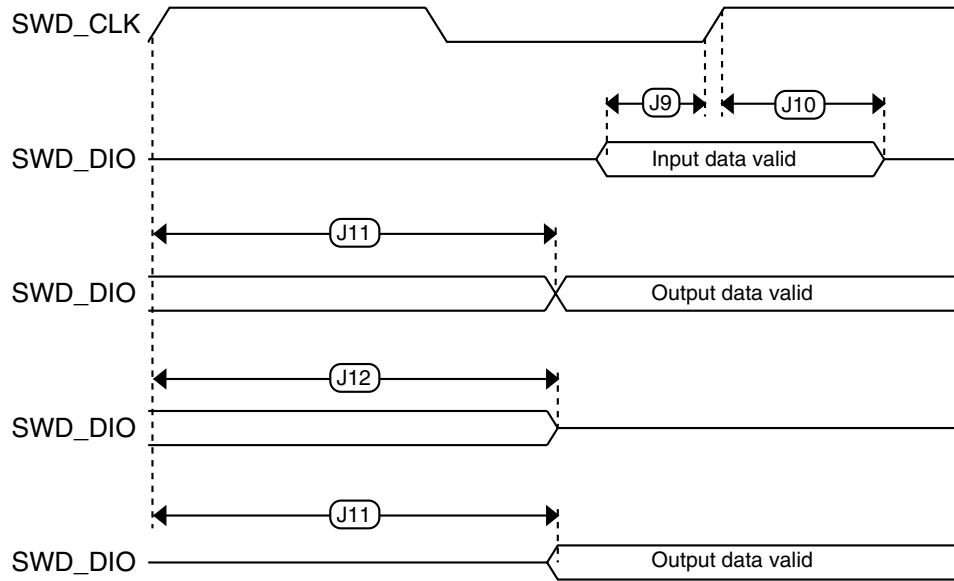

Figure 14. Serial wire data timing

6.2 External oscillator (OSC) and ICS characteristics

Table 11. OSC and ICS specifications (temperature range = -40 to 105 °C ambient)

Num	C	Characteristic		Symbol	Min	Typical ¹	Max	Unit
1	C	Crystal or resonator frequency	Low range (RANGE = 0)	f_{lo}	31.25	32.768	39.0625	kHz
	C		High range (RANGE = 1)	f_{hi}	4	—	24	MHz
2	D	Load capacitors		C1, C2	See Note ²			
3	D	Feedback resistor	Low Frequency, Low-Power Mode ³	R_F	—	—	—	$M\Omega$
			Low Frequency, High-Gain Mode		—	10	—	$M\Omega$
			High Frequency, Low-Power Mode		—	1	—	$M\Omega$
			High Frequency, High-Gain Mode		—	1	—	$M\Omega$
4	D	Series resistor - Low Frequency	Low-Power Mode ³	R_S	—	0	—	$k\Omega$
			High-Gain Mode		—	200	—	$k\Omega$
5	D	Series resistor - High Frequency	Low-Power Mode ³	R_S	—	0	—	$k\Omega$

Table continues on the next page...

**Table 11. OSC and ICS specifications (temperature range = -40 to 105 °C ambient)
(continued)**

Num	C	Characteristic		Symbol	Min	Typical ¹	Max	Unit
	D	Series resistor - High Frequency, High-Gain Mode	4 MHz		—	0	—	kΩ
	D		8 MHz		—	0	—	kΩ
	D		16 MHz		—	0	—	kΩ
6	C	Crystal start-up time low range = 32.768 kHz crystal; High range = 20 MHz crystal ^{4,5}	Low range, low power	t _{CSTL}	—	1000	—	ms
	C		Low range, high gain		—	800	—	ms
	C		High range, low power	t _{CSTH}	—	3	—	ms
	C		High range, high gain		—	1.5	—	ms
7	T	Internal reference start-up time		t _{IRST}	—	20	50	μs
8	P	Internal reference clock (IRC) frequency trim range		f _{int_t}	31.25	—	39.0625	kHz
9	P	Internal reference clock frequency, factory trimmed	T = 25 °C, V _{DD} = 5 V	f _{int_ft}	—	37.5	—	kHz
10	P	DCO output frequency range	FLL reference = f _{int_t} , flo, or f _{hi} /RDIV	f _{dco}	40	—	50	MHz
11	P	Factory trimmed internal oscillator accuracy	T = 25 °C, V _{DD} = 5 V	Δf _{int_ft}	-0.5	—	0.5	%
12	C	Deviation of IRC over temperature when trimmed at T = 25 °C, V _{DD} = 5 V	Over temperature range from -40 °C to 105°C	Δf _{int_t}	-1.2	—	1	%
			Over temperature range from 0 °C to 105°C	Δf _{int_t}	-0.5	—	1	
13	C	Frequency accuracy of DCO output using factory trim value	Over temperature range from -40 °C to 105°C	Δf _{dco_ft}	-1.7	—	1.5	%
			Over temperature range from 0 °C to 105°C	Δf _{dco_ft}	-1	—	1.5	
14	C	FLL acquisition time ^{4,6}		t _{Acquire}	—	—	2	ms
15	C	Long term jitter of DCO output clock (averaged over 2 ms interval) ⁷		C _{Jitter}	—	0.02	0.2	%f _{dco}

1. Data in Typical column was characterized at 5.0 V, 25 °C or is typical recommended value.
2. See crystal or resonator manufacturer's recommendation.
3. Load capacitors (C₁, C₂), feedback resistor (R_F) and series resistor (R_S) are incorporated internally when RANGE = HGO = 0.
4. This parameter is characterized and not tested on each device.
5. Proper PC board layout procedures must be followed to achieve specifications.
6. This specification applies to any time the FLL reference source or reference divider is changed, trim value changed, or changing from FLL disabled (FBELP, FBILP) to FLL enabled (FEI, FEE, FBE, FBI). If a crystal/resonator is being used as the reference, this specification assumes it is already running.
7. Jitter is the average deviation from the programmed frequency measured over the specified interval at maximum f_{Bus}. Measurements are made with the device powered by filtered supplies and clocked by a stable external clock signal. Noise injected into the FLL circuitry via V_{DD} and V_{SS} and variation in crystal oscillator frequency increase the C_{Jitter} percentage for a given interval.

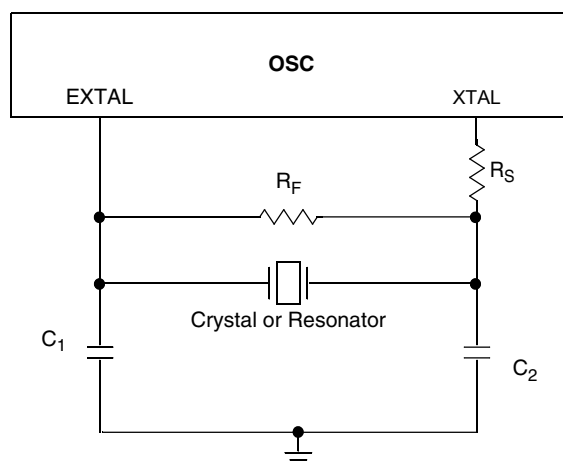

Figure 15. Typical crystal or resonator circuit

6.3 NVM specifications

This section provides details about program/erase times and program/erase endurance for the flash memories.

Table 12. Flash characteristics

C	Characteristic	Symbol	Min ¹	Typical ²	Max ³	Unit ⁴
D	Supply voltage for program/erase –40 °C to 105 °C	$V_{prog/erase}$	2.7	—	5.5	V
D	Supply voltage for read operation	V_{Read}	2.7	—	5.5	V
D	NVM Bus frequency	f_{NVMBUS}	1	—	24	MHz
D	NVM Operating frequency	f_{NVMOP}	0.8	1	1.05	MHz
D	Erase Verify All Blocks	t_{VFYALL}	—	—	2605	t_{cyc}
D	Erase Verify Flash Block	t_{RD1BLK}	—	—	2579	t_{cyc}
D	Erase Verify Flash Section	t_{RD1SEC}	—	—	485	t_{cyc}
D	Read Once	t_{RDONCE}	—	—	464	t_{cyc}
D	Program Flash (2 word)	t_{PGM2}	0.12	0.13	0.31	ms
D	Program Flash (4 word)	t_{PGM4}	0.21	0.21	0.49	ms
D	Program Once	$t_{PGMONCE}$	0.20	0.21	0.21	ms
D	Erase All Blocks	t_{ERSALL}	95.42	100.18	100.30	ms
D	Erase Flash Block	t_{ERSBLK}	95.42	100.18	100.30	ms
D	Erase Flash Sector	t_{ERSPG}	19.10	20.05	20.09	ms
D	Unsecure Flash	t_{UNSECU}	95.42	100.19	100.31	ms
D	Verify Backdoor Access Key	t_{VFYKEY}	—	—	482	t_{cyc}
D	Set User Margin Level	t_{MLOADU}	—	—	415	t_{cyc}
C	FLASH Program/erase endurance T_L to $T_H = -40\text{ °C to }105\text{ °C}$	n_{FLPE}	10 k	100 k	—	Cycles

Table continues on the next page...

Table 12. Flash characteristics (continued)

C	Characteristic	Symbol	Min ¹	Typical ²	Max ³	Unit ⁴
C	Data retention at an average junction temperature of $T_{Javg} = 85^{\circ}\text{C}$ after up to 10,000 program/erase cycles	t_{D_ret}	15	100	—	years

1. Minimum times are based on maximum f_{NVMOP} and maximum f_{NVMBUS}
2. Typical times are based on typical f_{NVMOP} and maximum f_{NVMBUS}
3. Maximum times are based on typical f_{NVMOP} and typical f_{NVMBUS} plus aging
4. $t_{cyc} = 1 / f_{NVMBUS}$

Program and erase operations do not require any special power sources other than the normal V_{DD} supply. For more detailed information about program/erase operations, see the Flash Memory Module section in the reference manual.

6.4 Analog

6.4.1 ADC characteristics

Table 13. 5 V 12-bit ADC operating conditions

Characteristic	Conditions	Symbol	Min	Typ ¹	Max	Unit	Comment
Supply voltage	Absolute	V_{DDA}	2.7	—	5.5	V	—
	Delta to V_{DD} ($V_{DD}-V_{DDA}$)	ΔV_{DDA}	-100	0	+100	mV	—
Input voltage		V_{ADIN}	V_{REFL}	—	V_{REFH}	V	—
Input capacitance		C_{ADIN}	—	4.5	5.5	pF	—
Input resistance		R_{ADIN}	—	3	5	k Ω	—
Analog source resistance	12-bit mode	R_{AS}	—	—	2	k Ω	External to MCU
	• $f_{ADCK} > 4$ MHz		—	—	5		
	• $f_{ADCK} < 4$ MHz		—	—	5		
10-bit mode	—	—	5	k Ω	External to MCU		
• $f_{ADCK} > 4$ MHz	—	—	10				
• $f_{ADCK} < 4$ MHz	—	—	10				
	8-bit mode (all valid f_{ADCK})		—	—	10		
ADC conversion clock frequency	High speed (ADLPC=0)	f_{ADCK}	0.4	—	8.0	MHz	—
	Low power (ADLPC=1)		0.4	—	4.0		

1. Typical values assume $V_{DDA} = 5.0$ V, Temp = 25°C , $f_{ADCK} = 1.0$ MHz unless otherwise stated. Typical values are for reference only and are not tested in production.

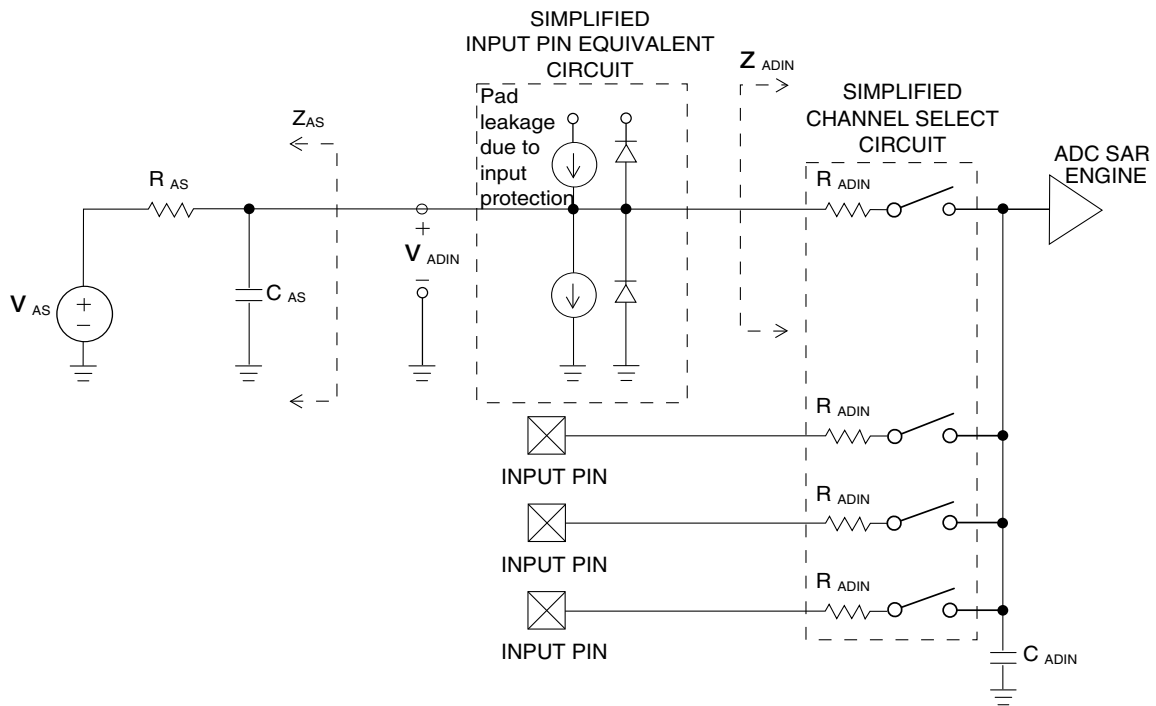

Figure 16. ADC input impedance equivalency diagram

Table 14. 12-bit ADC characteristics ($V_{REFH} = V_{DDA}$, $V_{REFL} = V_{SSA}$)

Characteristic	Conditions	C	Symbol	Min	Typ ¹	Max	Unit
Supply current ADLPC = 1 ADLSMP = 1 ADCO = 1		T	I_{DDA}	—	133	—	μA
Supply current ADLPC = 1 ADLSMP = 0 ADCO = 1		T	I_{DDA}	—	218	—	μA
Supply current ADLPC = 0 ADLSMP = 1 ADCO = 1		T	I_{DDA}	—	327	—	μA
Supply current ADLPC = 0 ADLSMP = 0 ADCO = 1		T	I_{DDA}	—	582	990	μA
Supply current	Stop, reset, module off	T	I_{DDA}	—	0.011	1	μA
ADC asynchronous clock source	High speed (ADLPC = 0)	P	f_{ADACK}	2	3.3	5	MHz

Table continues on the next page...

Table 14. 12-bit ADC characteristics ($V_{REFH} = V_{DDA}$, $V_{REFL} = V_{SSA}$) (continued)

Characteristic	Conditions	C	Symbol	Min	Typ ¹	Max	Unit
	Low power (ADLPC = 1)			1.25	2	3.3	
Conversion time (including sample time)	Short sample (ADLSMP = 0)	T	t_{ADC}	—	20	—	ADCK cycles
	Long sample (ADLSMP = 1)			—	40	—	
Sample time	Short sample (ADLSMP = 0)	T	t_{ADS}	—	3.5	—	ADCK cycles
	Long sample (ADLSMP = 1)			—	23.5	—	
Total unadjusted Error ²	12-bit mode	T	E_{TUE}	—	± 3.0	—	LSB ³
	10-bit mode	C		—	± 1.0	± 2.0	
	8-bit mode	T		—	± 0.8	—	
Differential Non-Linearity	12-bit mode	T	DNL	—	± 1.2	—	LSB ³
	10-bit mode ⁴	C		—	± 0.3	± 1.0	
	8-bit mode ⁴	T		—	± 0.15	—	
Integral Non-Linearity	12-bit mode	T	INL	—	± 1.2	—	LSB ³
	10-bit mode	C		—	± 0.3	± 1.0	
	8-bit mode	T		—	± 0.15	—	
Zero-scale error ⁵	12-bit mode	T	E_{ZS}	—	± 1.2	—	LSB ³
	10-bit mode	C		—	± 0.15	± 1.0	
	8-bit mode	T		—	± 0.3	—	
Full-scale error ⁶	12-bit mode	T	E_{FS}	—	± 1.8	—	LSB ³
	10-bit mode	C		—	± 0.7	± 1.0	
	8-bit mode	T		—	± 0.5	—	
Quantization error	≤ 12 bit modes	D	E_Q	—	—	± 0.5	LSB ³
Input leakage error ⁷	all modes	D	E_{IL}	$I_{in} * R_{AS}$			mV
Temp sensor slope	-40 °C–25 °C	D	m	—	3.266	—	mV/°C
	25 °C–125 °C			—	3.638	—	
Temp sensor voltage	25 °C	D	V_{TEMP25}	—	1.396	—	V

1. Typical values assume $V_{DDA} = 5.0$ V, Temp = 25 °C, $f_{ADCK} = 2.5$ MHz under FBE mode and alternate clock source (ALTCLK) is selected as ADC clock.
2. Includes quantization
3. $1 \text{ LSB} = (V_{REFH} - V_{REFL})/2^N$
4. Monotonicity and no-missing-codes guaranteed in 10-bit and 8-bit modes
5. $V_{ADIN} = V_{SSA}$
6. $V_{ADIN} = V_{DDA}$
7. I_{in} = leakage current (refer to DC characteristics)

6.4.2 Analog comparator (ACMP) electricals

Table 15. Comparator electrical specifications

C	Characteristic	Symbol	Min	Typical	Max	Unit
D	Supply voltage	V_{DDA}	2.7	—	5.5	V
T	Supply current (Operation mode)	I_{DDA}	—	10	20	μA
D	Analog input voltage	V_{AIN}	$V_{SS} - 0.3$	—	V_{DDA}	V
P	Analog input offset voltage	V_{AIO}	—	—	40	mV
C	Analog comparator hysteresis (HYST=0)	V_H	—	15	20	mV
C	Analog comparator hysteresis (HYST=1)	V_H	—	20	30	mV
T	Supply current (Off mode)	$I_{DDA\text{OFF}}$	—	60	—	nA
C	Propagation Delay	t_D	—	0.4	1	μs

6.5 Communication interfaces

6.5.1 SPI switching specifications

The serial peripheral interface (SPI) provides a synchronous serial bus with master and slave operations. Many of the transfer attributes are programmable. The following tables provide timing characteristics for classic SPI timing modes. See the SPI chapter of the chip's reference manual for information about the modified transfer formats used for communicating with slower peripheral devices. All timing is shown with respect to 20% V_{DD} and 80% V_{DD} , unless noted, and 25 pF load on all SPI pins. All timing assumes slew rate control is disabled and high-drive strength is enabled for SPI output pins.

Table 16. SPI master mode timing

Nu m.	Symbol	Description	Min.	Max.	Unit	Comment
1	f_{op}	Frequency of operation	$f_{BUS}/2048$	$f_{BUS}/2$	Hz	f_{BUS} is the bus clock
2	t_{SPSCK}	SPSCK period	$2 \times t_{BUS}$	$2048 \times t_{BUS}$	ns	$t_{BUS} = 1/f_{BUS}$
3	t_{Lead}	Enable lead time	1/2	—	t_{SPSCK}	—
4	t_{Lag}	Enable lag time	1/2	—	t_{SPSCK}	—
5	t_{WSPSCK}	Clock (SPSCK) high or low time	$t_{BUS} - 30$	$1024 \times t_{BUS}$	ns	—
6	t_{SU}	Data setup time (inputs)	8	—	ns	—
7	t_{HI}	Data hold time (inputs)	8	—	ns	—
8	t_v	Data valid (after SPSCK edge)	—	25	ns	—
9	t_{HO}	Data hold time (outputs)	20	—	ns	—
10	t_{RI}	Rise time input	—	$t_{BUS} - 25$	ns	—

Table continues on the next page...

Table 16. SPI master mode timing (continued)

Nu m.	Symbol	Description	Min.	Max.	Unit	Comment
	t_{FI}	Fall time input				
11	t_{RO}	Rise time output	—	25	ns	—
	t_{FO}	Fall time output				

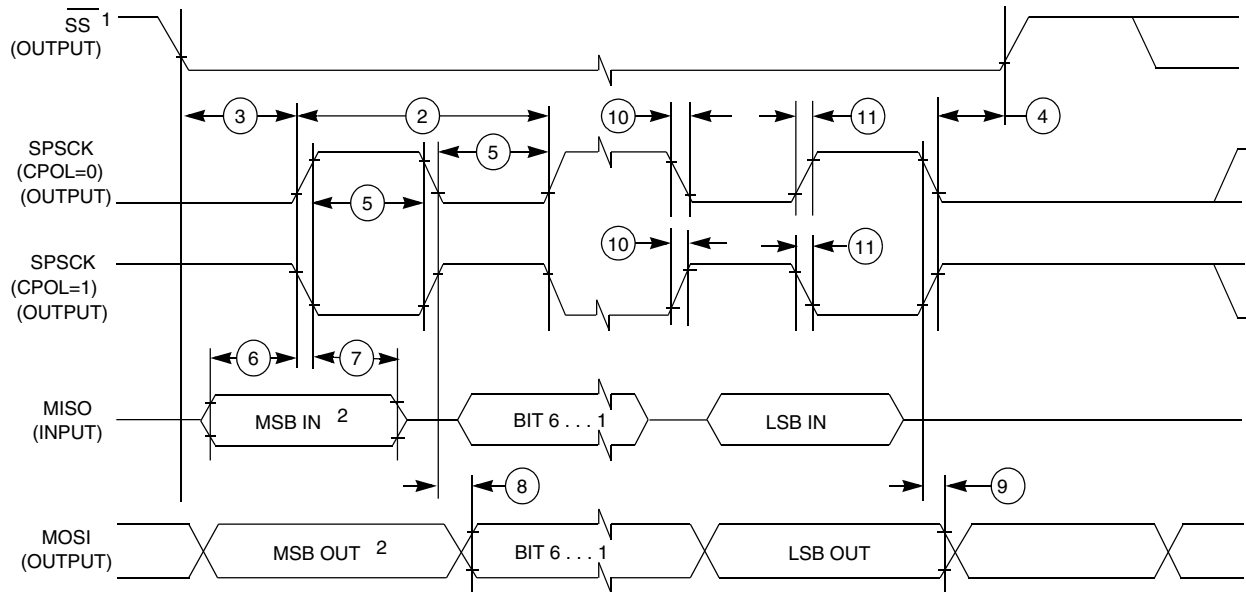

1. If configured as an output.
2. LSBF = 0. For LSBF = 1, bit order is LSB, bit 1, ..., bit 6, MSB.

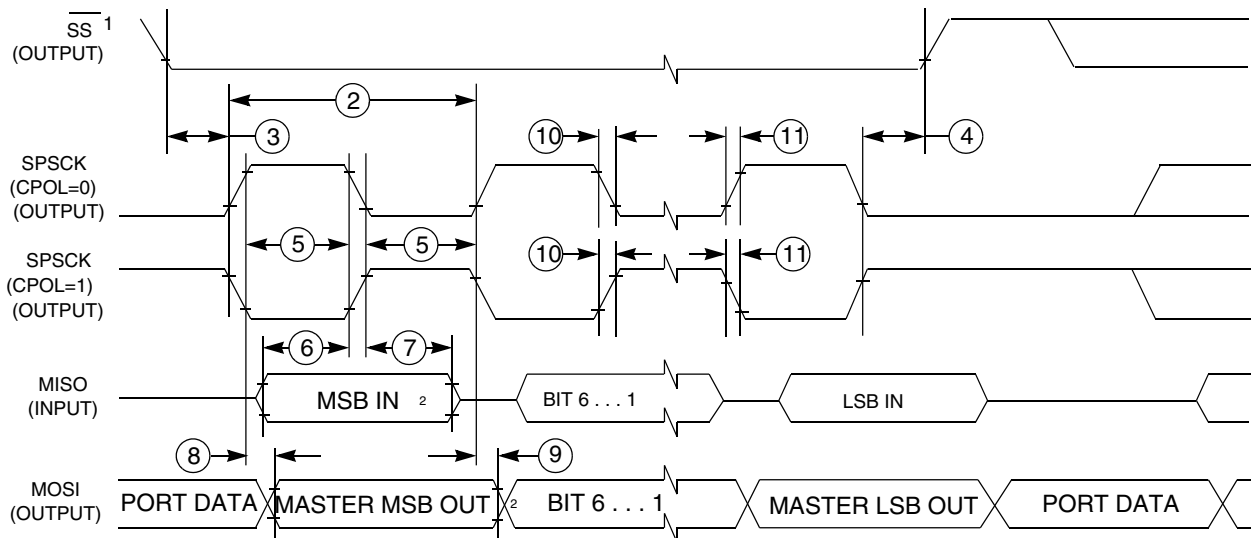
Figure 17. SPI master mode timing (CPHA=0)

1. If configured as output
2. LSBF = 0. For LSBF = 1, bit order is LSB, bit 1, ..., bit 6, MSB.

Figure 18. SPI master mode timing (CPHA=1)

Table 17. SPI slave mode timing

Nu m.	Symbol	Description	Min.	Max.	Unit	Comment
1	f_{op}	Frequency of operation	0	$f_{BUS}/4$	Hz	f_{BUS} is the bus clock as defined in Control timing .
2	t_{SPSCK}	SPSCK period	$4 \times t_{BUS}$	—	ns	$t_{BUS} = 1/f_{BUS}$
3	t_{Lead}	Enable lead time	1	—	t_{BUS}	—
4	t_{Lag}	Enable lag time	1	—	t_{BUS}	—
5	t_{WSPSCK}	Clock (SPSCK) high or low time	$t_{BUS} - 30$	—	ns	—
6	t_{SU}	Data setup time (inputs)	15	—	ns	—
7	t_{HI}	Data hold time (inputs)	25	—	ns	—
8	t_a	Slave access time	—	t_{BUS}	ns	Time to data active from high-impedance state
9	t_{dis}	Slave MISO disable time	—	t_{BUS}	ns	Hold time to high-impedance state
10	t_v	Data valid (after SPSCK edge)	—	25	ns	—
11	t_{HO}	Data hold time (outputs)	0	—	ns	—
12	t_{RI}	Rise time input	—	$t_{BUS} - 25$	ns	—
	t_{FI}	Fall time input				
13	t_{RO}	Rise time output	—	25	ns	—
	t_{FO}	Fall time output				

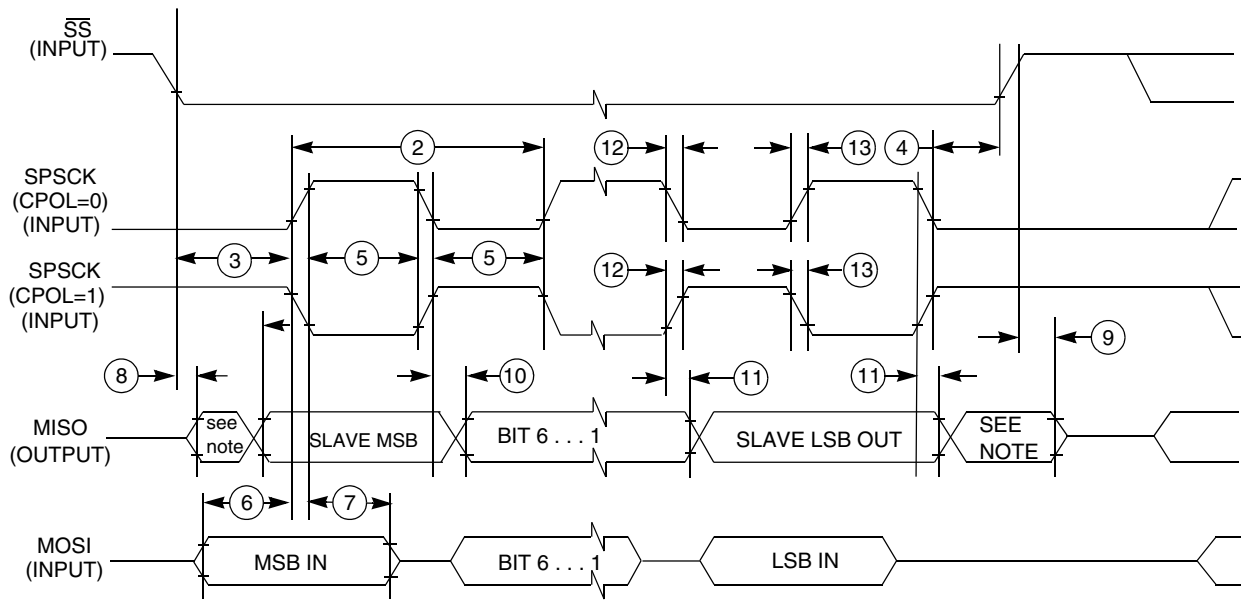

NOTE: Not defined

Figure 19. SPI slave mode timing (CPHA = 0)

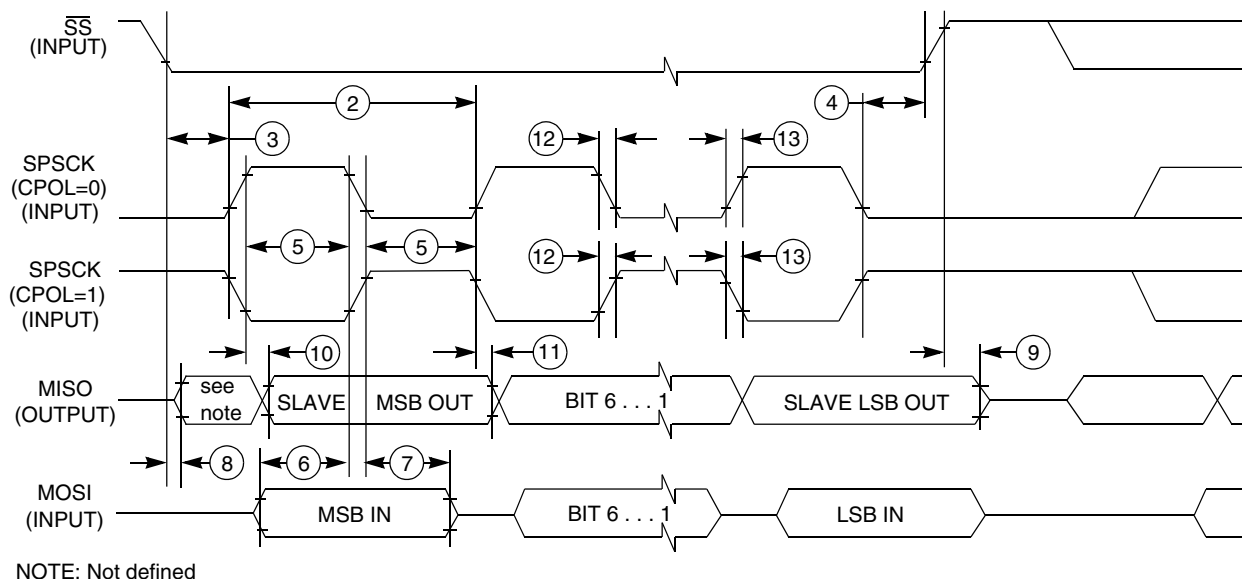

Figure 20. SPI slave mode timing (CPHA=1)

7 Dimensions

7.1 Obtaining package dimensions

Package dimensions are provided in package drawings.

To find a package drawing, go to freescale.com and perform a keyword search for the drawing's document number:

If you want the drawing for this package	Then use this document number
16-pin TSSOP	98ASH70247A
20-pin SOIC	98ASB42343B
24-pin QFN	98ASA00474D

8 Pinout

8.1 Signal Multiplexing and Pin Assignments

The following table shows the signals available on each pin and the locations of these pins on the devices supported by this document.

NOTE

- PTB5, PTC1, and PTC5 pins support high-current drive output, refer to the PORT_HDRVE register in Port Control chapter for details.
- VDD and VREFH are internally connected. Only one pin (VDD or VREFH) is available on chip.
- VSS and VREFL are internally connected. Only one pin (VSS or VREFL) is available on chip.
- PTA2 and PTA3 are true open-drain pins when operated as output

24 QFN	20 SOIC	16 TSSOP	Pin Name	Default	ALT0	ALT1	ALT2	ALT3	ALT4	ALT5	ALT6	ALT7
1	—	—	PTC5	DISABLED	PTC5	KB11_P1	FTM2_CH3	BUSOUT				
2	—	—	PTC4	DISABLED	PTC4	KB11_P0	FTM2_CH2		PWT_IN0			
3	3	3	VDD	VDD							VDD	
3	3	3	VREFH	VDDA/ VREFH						VDDA	VREFH	
4	4	4	VREFL	VREFL							VREFL	
4	4	4	VSS	VSS/ VSSA						VSSA	VSS	
5	5	5	PTB7	EXTAL	PTB7		I2C0_SCL				EXTAL	
6	6	6	PTB6	XTAL	PTB6		I2C0_SDA				XTAL	
7	7	7	PTB5	ACMP1_OUT	PTB5	KB11_P7	FTM2_CH5	SPI0_PCS	ACMP1_OUT			
8	8	8	PTB4	NMI_b	PTB4	KB11_P6	FTM2_CH4	SPI0_MISO	ACMP1_IN2	NMI_b		
9	9	—	PTC3	ADC0_SE11	PTC3	KB11_P5	FTM2_CH3				ADC0_SE11	
10	10	—	PTC2	ADC0_SE10	PTC2	KB11_P4	FTM2_CH2				ADC0_SE10	
11	11	—	PTC1	ADC0_SE9	PTC1	KB11_P3	FTM2_CH1				ADC0_SE9	
12	12	—	PTC0	ADC0_SE8	PTC0	KB11_P2	FTM2_CH0				ADC0_SE8	
13	13	9	PTB3	ADC0_SE7	PTB3	KB10_P7	SPI0_MOSI	FTM0_CH1			ADC0_SE7	
14	14	10	PTB2	ADC0_SE6	PTB2	KB10_P6	SPI0_SCK	FTM0_CH0	ACMP0_IN0		ADC0_SE6	
15	15	11	PTB1	ADC0_SE5	PTB1	KB10_P5	UART0_TX	SPI0_MISO	TCLK2		ADC0_SE5	
16	16	12	PTB0	ADC0_SE4	PTB0	KB10_P4	UART0_RX	SPI0_PCS	PWT_IN1		ADC0_SE4	
17	—	—	PTA7	ADC0_SE3	PTA7		FTM2_FLT2	SPI0_MOSI	ACMP1_IN1		ADC0_SE3	
18	—	—	PTA6	ADC0_SE2	PTA6		FTM2_FLT1	SPI0_SCK	ACMP1_IN0		ADC0_SE2	
19	17	13	PTA3	DISABLED	PTA3	KB10_P3	UART0_TX	I2C0_SCL				
20	18	14	PTA2	DISABLED	PTA2	KB10_P2	UART0_RX	I2C0_SDA				
21	19	15	PTA1	ADC0_SE1	PTA1	KB10_P1	FTM0_CH1		ACMP0_IN1		ADC0_SE1	
22	20	16	PTA0	SWD_CLK	PTA0	KB10_P0	FTM0_CH0	RTCO	ACMP0_IN2	ADC0_SE0	SWD_CLK	
23	1	1	PTA5	RESET_b	PTA5	IRQ	TCLK1				RESET_b	
24	2	2	PTA4	SWD_DIO	PTA4				ACMP0_OUT		SWD_DIO	

8.2 Device pin assignment

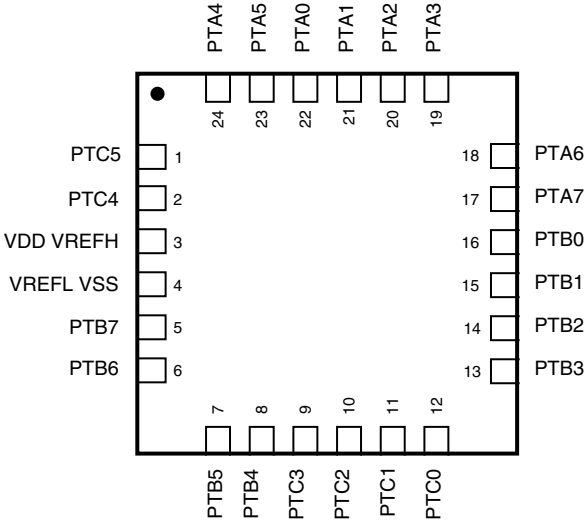

Figure 21. 24-pin QFN package

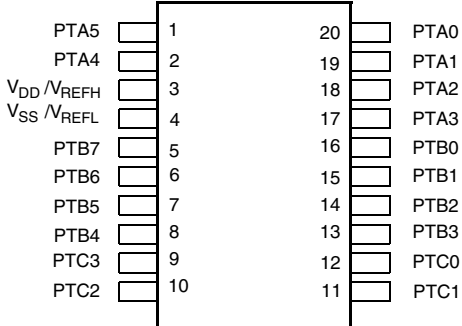

Figure 22. 20-pin SOIC package

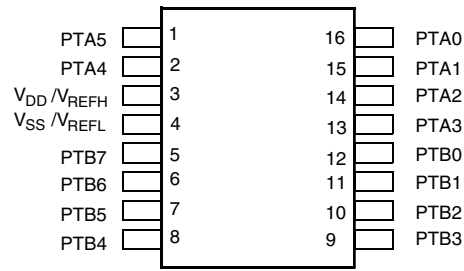

Figure 23. 16-pin TSSOP package

9 Revision history

The following table provides a revision history for this document.

Table 18. Revision history

Rev. No.	Date	Substantial Changes
3	3/2014	Initial public release

How to Reach Us:

Home Page:

freescale.com

Web Support:

freescale.com/support

Information in this document is provided solely to enable system and software implementers to use Freescale products. There are no express or implied copyright licenses granted hereunder to design or fabricate any integrated circuits based on the information in this document. Freescale reserves the right to make changes without further notice to any products herein.

Freescale makes no warranty, representation, or guarantee regarding the suitability of its products for any particular purpose, nor does Freescale assume any liability arising out of the application or use of any product or circuit, and specifically disclaims any and all liability, including without limitation consequential or incidental damages. "Typical" parameters that may be provided in Freescale data sheets and/or specifications can and do vary in different applications, and actual performance may vary over time. All operating parameters, including "typicals," must be validated for each customer application by customer's technical experts. Freescale does not convey any license under its patent rights nor the rights of others. Freescale sells products pursuant to standard terms and conditions of sale, which can be found at the following address: freescale.com/SalesTermsandConditions.

Freescale, the Freescale logo, and Kinetis are trademarks of Freescale Semiconductor, Inc., Reg. U.S. Pat. & Tm. Off. All other product or service names are the property of their respective owners. ARM and Cortex-M0+ are the registered trademarks of ARM Limited.

©2013-2014 Freescale Semiconductor, Inc.